

**SEEPEX.**  
ALL THINGS FLOW

# THE BASIS PRODUCT GROUP N

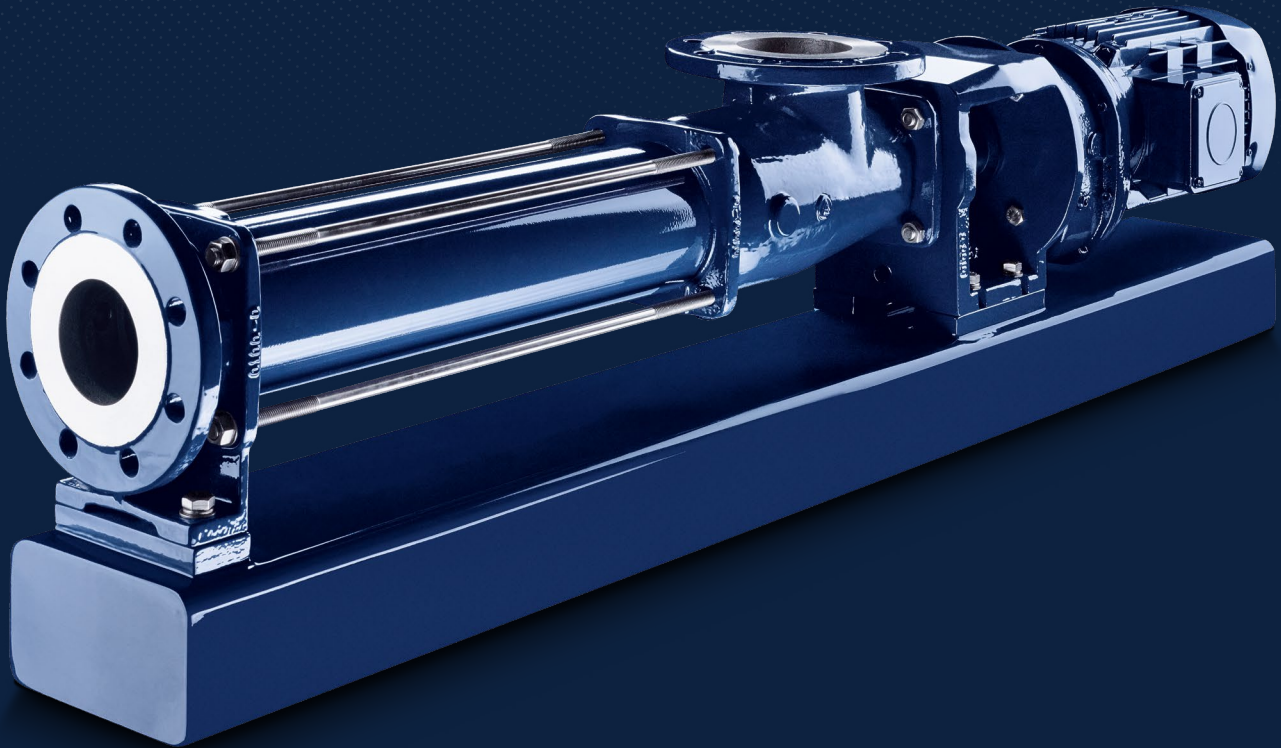

# AN ESSENTIAL.

Product group N pumps are the model for the design of all SEEPEX progressive cavity pumps. They are used in all industries and convey thin to highly viscous liquids with or without solids. They are available with various rotor/stator geometries (conventional, 6L, Tricam and Equal Wall). These benefits and others ensure the pump's economical operation.

**DRY RUNNING PROTECTION TSE; THERMOELECTRONIC SENSOR**

Prevents the stator from being damaged by dry running. Optionally available.

**ROTOR**

Wear and corrosion resistant materials. Hard coatings are also available.

**PRESSURE BRANCH**

Connection for pressure instruments. Flange connections in DIN or ANSI.

**STATOR**

The seal on both ends is molded as an integral part of the elastomer. Corrosion of the stator tube is prevented as the pumped liquid does not come in contact with the metal tube or the bonding adhesive. Available with an adjustable stator retensioning device.

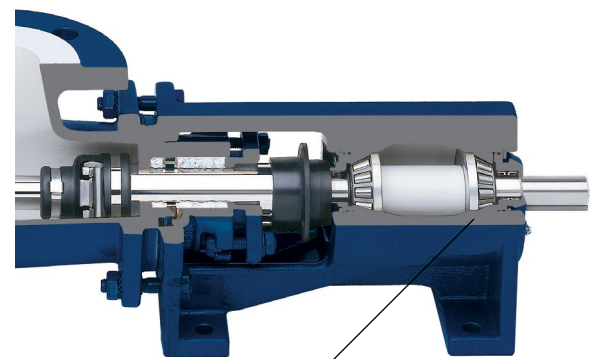

**DRIVE CASING**

For NS range, drive shaft and bearings can be lubricated. Available with double bearing seals to prevent ingress of dust or moisture.

**UNIVERSAL JOINT SLEEVE PROTECTION**

Made of stainless steel, protects the universal joint sleeve against mechanical damage from large or sharp solids. Optionally available.

**UNIVERSAL JOINT**

Consists of just five components. Power transmission through wear resistant, hardened and replaceable joint parts: easily repaired.

**UNIVERSAL JOINT SLEEVE WITH HOLDING BANDS**

Protects the grease-filled joints from penetration by the pumped liquid, even in case of maximum vacuum or pressure loading. The streamlined design reduces turbulence and NPSHr.

**SHAFT SEALING**

Gland packing with optional lantern ring. Balanced or unbalanced, component or cartridge, single or double mechanical seals from numerous suppliers are available. Quench and flushing systems are also available. Adheres to the DIN EN 12756 standards.

**LANTERN**

For connecting the pump and drive. To secure the assembly to the baseplate.

**DRIVE**

Gearmotors, variable speed drives or hydraulic motors from all major manufacturers can be directly flanged to the pump without additional couplings or guards.

**PLUG-IN SHAFT CONNECTION**

For easy dismantling of the pump and drive with quick replacement of the rotating parts and shaft seals. The plug-in shaft pin secures the shaft connection to the drive and the splash ring protects the bearings from contamination.

**PLUG-IN SHAFT**

Connects the drive shaft to the universal joint; with gland packing the plug-in shaft functions as a shaft sleeve. It is available with wear resistant hard coatings.

**TIE BOLTS/SCREWS**

Corrosion proof. Available in stainless steel.

**INSPECTION PORTS**

On both sides as an option.

**COUPLING ROD**

For power transmission. Improved design, special designs with augers or paddles are available.

**SUCTION CASING**

With large cross section, drain plug and connections for pressure instruments. Designed for laminar flow conditions. Flange connections in DIN or ANSI can be rotated in 90° increments.

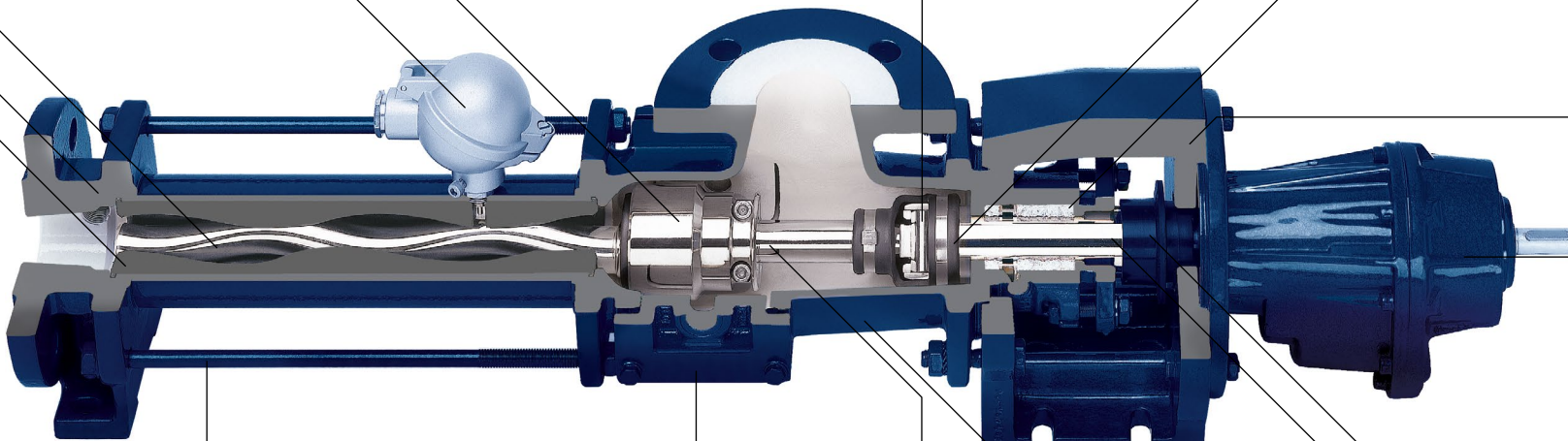

## OVERVIEW OF RANGES

**BN RANGE**

The drive of BN range pumps is flange-mounted directly to the pump. This means that a separate pump bearing is not necessary and the pump is more compact and less expensive. The plug-in shaft connection between the drive and rotating unit simplifies the replacement of rotating wearing parts and the shaft sealing, thereby making the BN range very service-friendly.

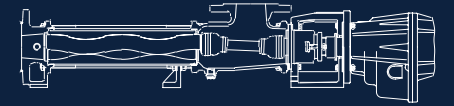

**NS/N RANGE**

NS range pumps have drives not directly flange-mounted to the pump. Bare shaft designs can fit any drive the user desires including diesel engines or hydraulic motors. The drive casing can accommodate elastic couplings or belt pulleys and still has a service-friendly plug-in shaft connection. This connection simplifies the replacement of the rotating wearing parts and the shaft sealing.

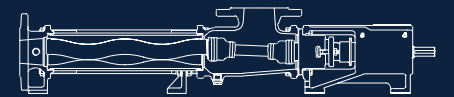

## APPLICATIONS

Product group N pumps form the basis of the modular concept that supports all SEEPEX progressive cavity pumps. They are ideal for applications in agriculture, ceramics, chemicals, biochemicals, construction, dyeing, paints, electroplating, environmental technology, fish processing, food, beverages, bakery dough and fillings, mining, inorganic minerals, oil and natural gas production, offshore technologies, cosmetics, petrochemicals, pharmaceuticals, pulp and paper, shipbuilding, sugar refining, water and wastewater treatment, textiles, glues, adhesives, mastics and sealers in the transportation and construction markets.

### FEATURES

- Various rotor/stator geometries (conventional, 6L, Tricam and Equal Wall)
- Minimal pulsation, uniform and controlled flow. No pulsation dampeners or compensators are required.
- High self-priming capabilities even with a mixture of liquid and air/gas up to a 9 m (29.5 ft.) water column
- Can be mounted either horizontally or vertically, suction casing inlet can be rotated
- Large spherical entrance ports for improved solids handling
- Products with solids can be conveyed gently without damage
- Reversible rotation and fluid flow to improve the NPSHr and sealing
- Low shear rates

### KEY FACTS

- Conveying capacity:  
30 l/h–500 m<sup>3</sup>/h (0.132–2,200 USGPM)
- Pressure (higher pressures upon request):  
up to 48 bar (720 psi)

**SEEPEX GmbH**  
[www.seepex.com](http://www.seepex.com)