



Heat of Compression Desiccant Air Dryers

NRG-LES SERIES 350 -10000 scfm (595 - 16990 nm³/h)



Since 1946, the world has turned to Pneumatic Products for the quality and service demanded by the most critical of applications. Global leaders of industry require durable components that deliver unquestionable reliability. Our precision engineered components and designs deliver outstanding service life and operational longevity. Invest in our experience and gain annuities that will grow for years.

Based in Charlotte, North Carolina, SPX Corporation (NYSE: SPW) is a global Fortune 500 multi-industry manufacturing leader. For more information, please visit www.spx.com

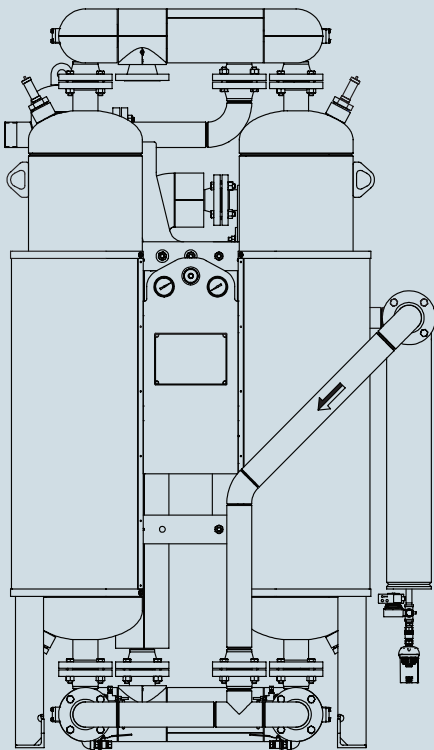

Where Ideas Meet Industry

Pneumatic Products' NRG-LES Series heat of compression desiccant air dryers provide a cost effective solution to remove moisture from compressed air. The sustainable energy saving design reduces operating costs and delivers instrument quality air.

Thermal energy generated during the air compression process is effectively utilized to regenerate the off-line desiccant bed. Ideally suited for oil-free air compressors, NRG-LES Series dryers turn "waste heat" into energy savings.

Advantages:

- Delivers ISO 8573.1: 2010 Air Quality Class 2 to 4 pressure dew point (-40°F to +37°F), dependent on air compressor discharge temperature
- Minimal power required, providing low cost of operation and rapid return on investment
- Desiccant in the off-line tower is regenerated without the use of purge air, requiring no increase in air compressor capacity
- Low outlet pressure dew points achieved without the use of blowers or booster heaters
- Fully packaged, skid mounted design, provides ease of installation

Reduce Life Cycle Costs

The NRG-LES consumes under 50 watts, less than the power requirement of a typical lap-top computer.

The energy efficient design offers the lowest cost of operation as compared to conventional dehydration technology.

Annual Cost of Operation

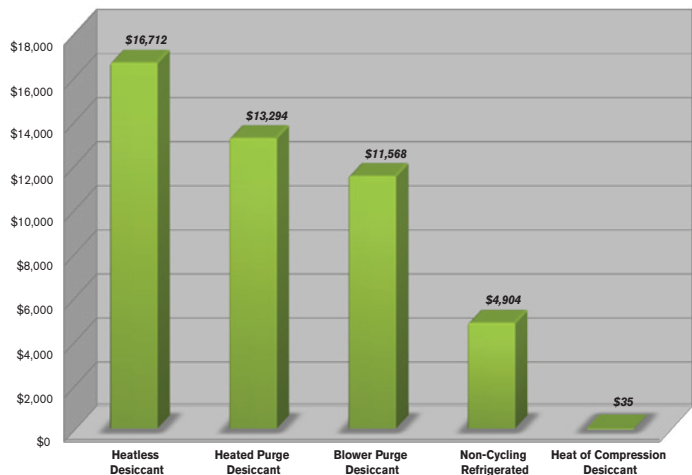

Annual cost of operation based on:

- Air flow: 1000 scfm
- Cost of power: \$0.10 kWh
- Operating time: 8000 hours

Better By Design



Front View: Model NRG1025

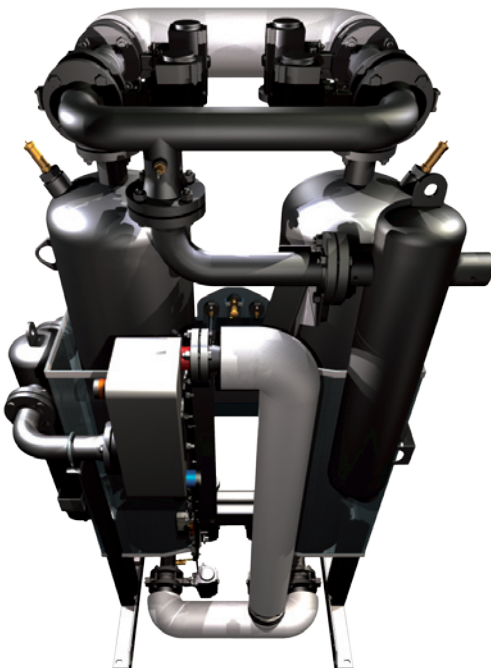

Back View: Model NRG1025

Standard Features:

- Pressure vessels are designed in accordance with the ASME Boiler and Pressure Vessel Code Section VIII Division 1
- ASME rated pressure relief valves control pressure build-up due to process upset
- Expanded metal personnel protection and hot pipe insulation provides added safety measures
- NEMA4/4X, IP66 rated controller, polycarbonate enclosure for protection in corrosive environments
- Flow models 350 to 450 scfm employ angle seat valves for reliable operation
- Flow models 600 to 10000 scfm utilize non-lubricated, high performance butterfly valves
- Front panel is equipped with left and right tower pressure gauges and moisture indicator for “at a glance” performance
- Towers are filled with high grade desiccant maintaining optimal performance under high temperatures
- 316 AISI stainless steel, brazed plate heat exchanger provides efficient cooling and corrosion resistance
- Fully insulated filter/separator removes bulk liquids and solid particles greater than 3.0 micron in size
- An electric demand drain serves as the primary drain, efficiently removing condensate without loss of air
- A timed electric drain acts as back-up, providing fail safe operation
- Factory mounted high temperature after-filter, rated for 450°F, removes solid particles 1.0 micron and larger

Options:

- Tower insulation
- Moisture sensing dew point demand control with alarm
- Valve failure to shift alarm

Putting Waste Heat to Good Use

How the NRG-LES Series Works:

1. Hot oil-free air, generated by the air compressor, is directed into the dryer by a high performance switching valve.
2. The hot air flows downward through the off-line tower, effectively regenerating the desiccant bed.
3. Hot, moist air then travels to the water-cooled heat exchanger. The cooling water runs counter-flow to the hot air causing water vapor in the air to condense.
4. Condensed liquid is removed in a high performance, two-stage filter/separator. Bulk liquid and solid particles 3.0 micron and larger are captured.
5. Condensate is discharged by an energy efficient, no-air-loss demand drain. The system is equipped with a back-up drain providing fail safe operation.
6. The pre-cooled air flows upward through the on-line tower and is dried to the specified pressure dew point.
7. Air travels through a high temperature after-filter removing solid particles 1.0 micron and larger. Dry, oil-free air enters the system for use.
8. The cycle is reversed based on a one hour fixed time (30 minutes regenerating/30 minutes drying), or on an extended cycle. The cycle is extended based on the regenerating tower temperature or optional pressure dew point.

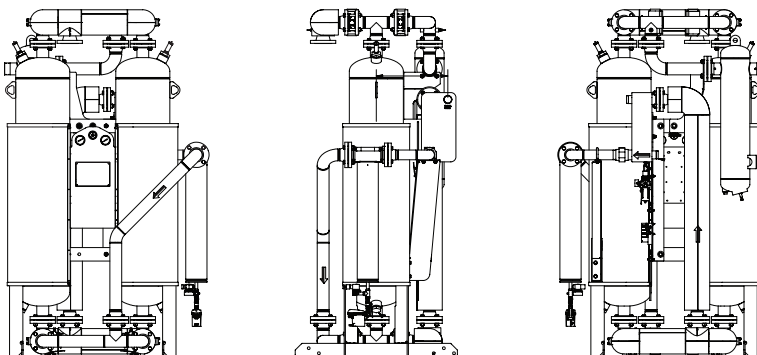
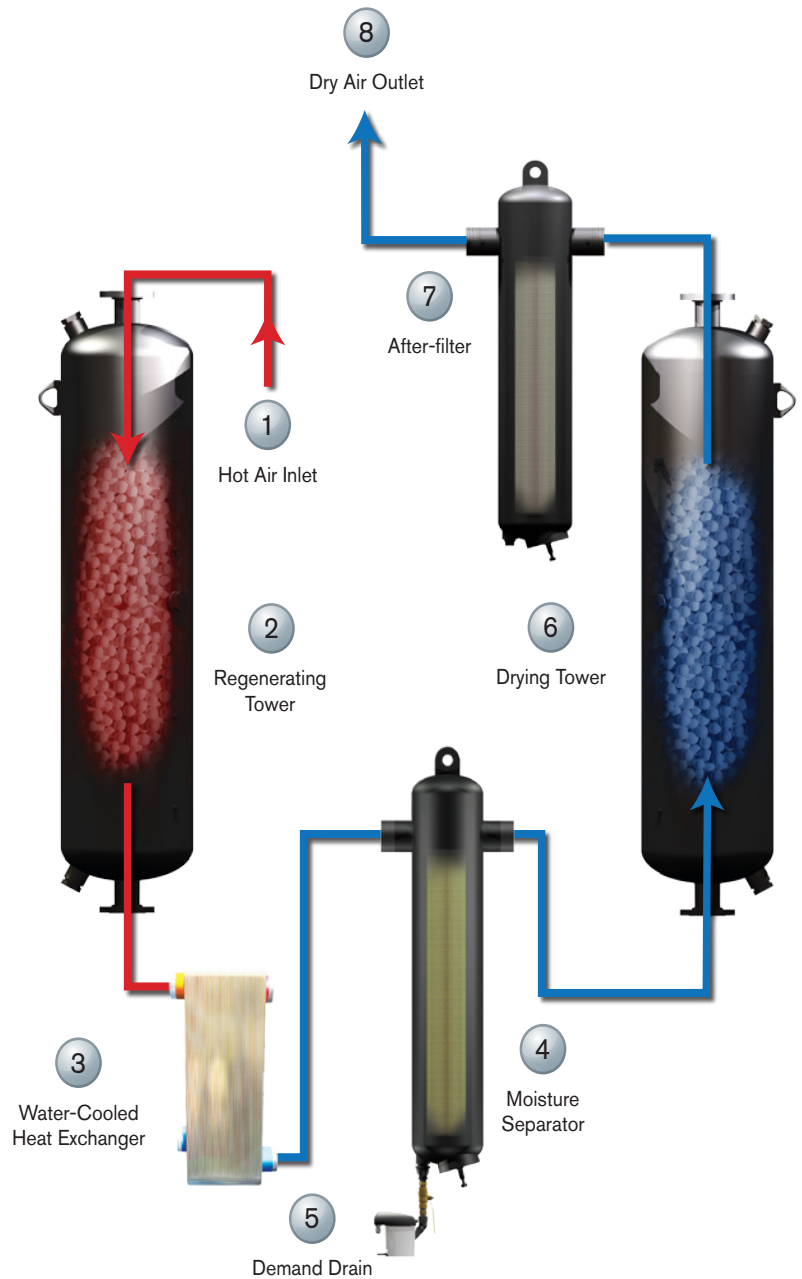

Understanding Dew Point Performance

The Air Compression Process

Site conditions are important when understanding dew point performance of heat of compression air dryers. The NRG-LES flow ratings are based on an ambient air temperature of 85°F (29°C) and 60% relative humidity. When compressed to 100 psig (7 bar) and heated to 350°F (160°C), the air leaving the compressor will possess a relative humidity of 3%. The dry, hot discharge air effectively regenerates the off-line desiccant bed.

The Effect of Regeneration Temperature

The NRG-LES utilizes recoverable heat energy from the air compressor to regenerate the off-line bed.

- Higher inlet air temperatures improve regeneration efficiency, delivering lower pressure dew points.
- Cooler inlet air temperatures decrease regeneration efficiency, delivering higher pressure dew points.

Performance Basis:

- Operating Pressure: 100 psig (7 bar)
- Ambient Air Temperature: 85°F (29°C)
- Ambient Relative Humidity: 60%
- Ambient Dew Point: 70°F (21°C)

Pressure Dew Point Performance

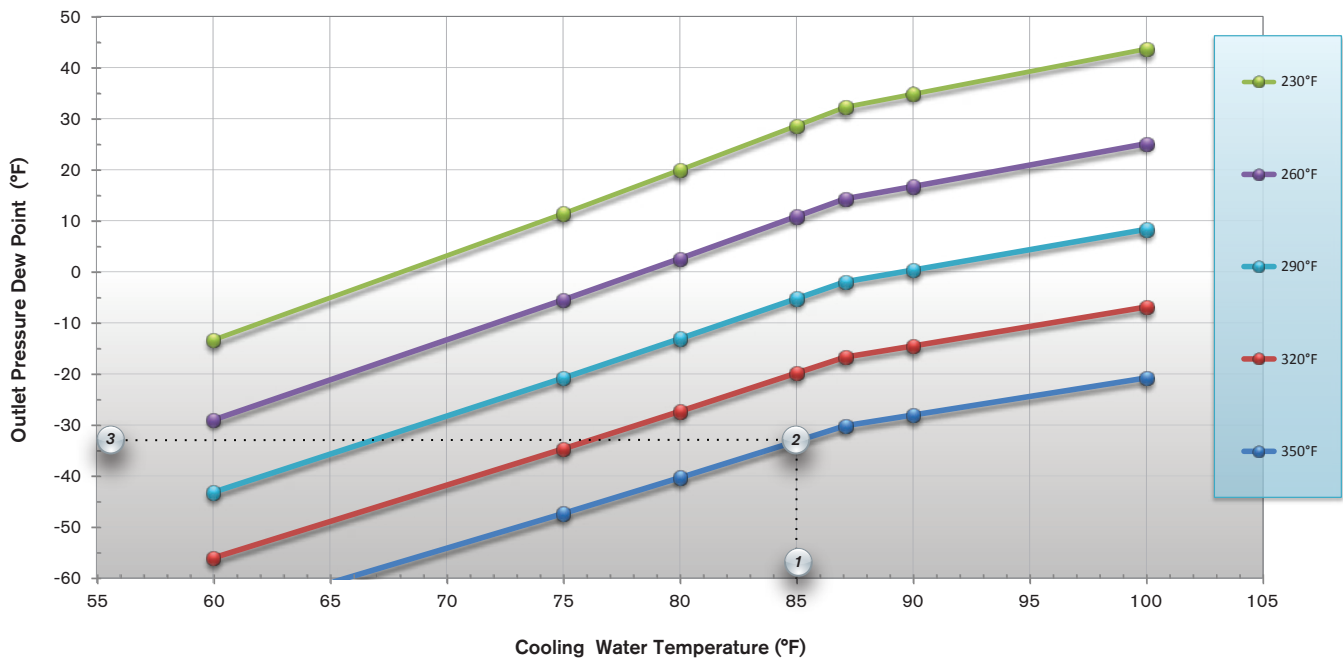

The chart above demonstrates the effect of cooling water temperature & compressor discharge temperatures to pressure dew point.

How to use the Dew Point Performance Chart:

- Locate the cooling water temperature on the X-axis.
Note: Inlet temperature to drying tower equals cooling water temperature plus 10°F.
- Proceed vertically up the graph line to where the cooling water temperature and compressor discharge temperature intersect.
- From this coordinate, advance laterally across the graph line to the Y-axis to determine pressure dew point (°F).

Example:

- Cooling water temperature = 85°F
- Compressor discharge temperature = 350°F
- Resulting pressure dew point = -33°F

Ease of Monitoring

The NRG-LES controller is furnished with a comprehensive diagnostic system that provides real-time operating status, service due messages and fault conditions. Information is communicated in a highly visible, two (2) line —sixteen (16) character vacuum florescent text display screen. The controller is equipped with an RS 232 communications port and Modbus registers for remote monitoring

Status Text Display Screens

- Tower drying (left/right)
- Tower regenerating (left/right)
- Hours to service (filters/valves/desiccant)
- Inlet air temperature (°F/°C)
- Outlet air temperature (°F/°C)
- Left tower temperature (°F/°C)
- Right tower temperature (°F/°C)



Dryer Alarm Text Display Screens

- Demand drain failure
- Low inlet air temperature (°F/°C)
- High drying temperature (°F/°C)
- Service due (filters/valves/desiccant)
- Temperature sensor failure

Optional:

- Outlet pressure dew point alarm (°F/°C)
- Valve position sensing- alarms on failure to shift

Indicating Lights (LED)

- Tower status (drying/regenerating)
- Power on (green)
- Master alarm light (red)
- Service due (amber)

Panel Mounted Instrumentation

- Left and right tower pressure gauges
- Color change moisture indicator

Optional Dew Point Demand Control System

A dew point demand control system automatically extends the drying cycle to compensate for changes in operating conditions. By sampling exit air from the drying tower, the Demand Control System delays tower switchover until the moisture content at the sample port rises to the predetermined set point.



Product Specifications

OPERATING CONDITIONS	MINIMUM	DESIGN	MAXIMUM
Regeneration Temperature	200°F	Customer specific	450°F
Inlet Air Pressure	60 psig	100 psig	150 psig
Ambient Air Temperature	40°F	85°F	120°F
Ambient Relative Humidity	—	60°F	—
Inlet Air Temperature (drying)	50°F	95°F	120°F
Cooling Water Temperature	40°F	85°F	110°F

DRYER MODEL	RATED FLOW ⁽¹⁾		DIMENSIONS						APPROXIMATE WEIGHT		INLET/OUTLET CONNECTIONS	COOLING WATER FLOW
	SCFM	NM ³ /H	H		W		D		LB	KG	IN	GPM @ 85°F
			IN	MM	IN	MM	IN	MM				
NRG350	350	560	96	2438	54	1372	43	1092	1794	814	2 x 3 NPT	8.7
NRG450	450	720	96	2438	56	1422	43	1092	1794	814	2 x 3 NPT	11.0
NRG600	600	960	105	2667	63	1600	50	1270	2294	1041	3 FLG x 3 NPT	15.0
NRG800	800	1280	105	2667	63	1600	50	1270	2518	1142	3 FLG x 3 NPT	20.0
NRG1025	1025	1640	108	2743	65	1651	48	1219	2818	1278	3 FLG x 3 NPT	26.0
NRG1300	1300	2080	115	2921	71	1803	62	1575	3438	1559	4 FLG	32.0
NRG1500	1500	2400	114	2896	77	1956	62	1575	4038	1832	4 FLG	37.0
NRG1800	1800	2880	119	3023	79	2007	62	1575	4538	2058	4 FLG	45.0
NRG2100	2100	3360	114	2896	87	2210	62	1575	5572	2527	4 FLG	52.0
NRG2400	2400	3840	116	2946	89	2261	67	1702	6472	2936	4 FLG	60.0
NRG3250	3250	5200	134	3404	99	2515	68	1727	7878	3573	6 FLG	81.0
NRG3700	3700	5920	126	3200	98	2489	85	2159	9638	4372	6 FLG	92.0
NRG4425	4425	7080	Consult Factory									
NRG5000	5000	8000										
NRG6100	6100	9760										
NRG7500	7500	12000										
NRG8500	8500	13600										
NRG10000	10000	16000										

1 Flow ratings based on 100 psig operating pressure; 85°F cooling water; 95°F air temperature into drying tower.

2 Shipping weight includes factory mounted 1.0 micron after-filter.

NRG-LES Series

350 to 10000 scfm
(595 - 16990 nm³/h)



ISO Quality Classes

Air Quality Classes	Solid Particles			Water		Oil	
	Maximum number of particles per m ³			Vapor Pressure Dew Point		Total Oil Concentration: Aerosol, Liquid and Vapor	
ISO 8573-1:	0.10 - 0.5 micron	0.5 - 1.0 micron	1.0 - 5.0 micron	°C	°F	mg / m ³	ppm _{w/w}
2010							
0	As specified by the equipment user or supplier and more stringent than class 1						
1	≤ 20,000	≤ 400	≤ 10	≤ -70	≤ -94	0.01	0.008
2	≤ 400,000	≤ 6,000	≤ 100	≤ -40	≤ -40	0.1	0.08
3	-	≤ 90,000	≤ 1,000	≤ -20	≤ -4	1	0.8
4	-	-	≤ 10,000	≤ +3	≤ +37	5	4
5	-	-	≤ 100,000	≤ +7	≤ +45	-	-

ISO Quality Class Performance:

NRG-LES with After-Filter

- Class 2: Solids
- Class 2-4: Pressure Dew Point

Correction Factors

Flow Multiplier for Dryer Selection

INLET TEMP TO DRYING TOWER* °F (°C)		85°F (29°C)	90°F (32°C)	95°F (35°C)	100°F (38°C)	105°F (41°C)	110°F (43°C)
Pressure psig (bar)	60 (4)	1.2	1.4	1.7	2.0	2.3	2.8
	70 (5)	1.0	1.2	1.4	1.7	2.0	2.4
	80 (6)	0.9	1.1	1.3	1.5	1.7	2.1
	90 (6)		0.9	1.1	1.3	1.6	1.8
	100 (7)		0.8	1.0	1.2	1.4	1.7
	110 (8)			0.9	1.1	1.3	1.5
	120 (8)			0.8	1.0	1.2	1.4
	130 (9)			0.8	0.9	1.1	1.3
	140 (10)			0.7	0.8	1.0	1.2

* Inlet temperature to drying tower = cooling water temperature +10°F

SPX FLOW TECHNOLOGY

4647 SW 40th Avenue

Ocala, Florida 34474-5788 U.S.A.

P: (352) 873-5793

F: (352) 873-5770

E: pneumatic.products.sales@spx.com

www.pneumaticproducts.com

www.spx.com

SPX reserves the right to incorporate our latest design and material changes without notice or obligation.

Design features, materials of construction and dimensional data, as described in this bulletin, are provided for your information only and should not be relied upon unless confirmed in writing. Please contact your local sales representative for product availability in your region. For more information visit www.spx.com.

The green ">" is a trademark of SPX Corporation, Inc.

ISSUED 07/2012 NRG-LES_US

COPYRIGHT © 2012 SPX Corporation