

## Blower Purge Desiccant Dryers

CAB SERIES 1,238 -12,915 scfm



## Superior Efficiency, Legendary Design

Since 1946, the world has turned to SPX FLOW's Pneumatic Products brand for the quality and service demanded by the most critical of applications. Global leaders of industry require durable components that deliver unquestionable reliability. Our precision engineered components and designs deliver outstanding service life and operational longevity. Invest in our experience and gain annuities that will grow for years.

CAB Series dryers use atmospheric blowers to deliver 100% inlet-to-outlet compressed air capacity and superior energy efficiency. Everyone knows, heat rises. Our legendary down flow drying process takes advantage of that principle. In regeneration mode, atmospheric air, stored heat of adsorption and a high-efficiency external heater combine to evacuate the collected water vapor. Operating at full, design load conditions, inlet-to-outlet air volume remains constant and -40°F (-40°C) pressure dew points are produced. CAB Series dryers deliver superior efficiency by design.

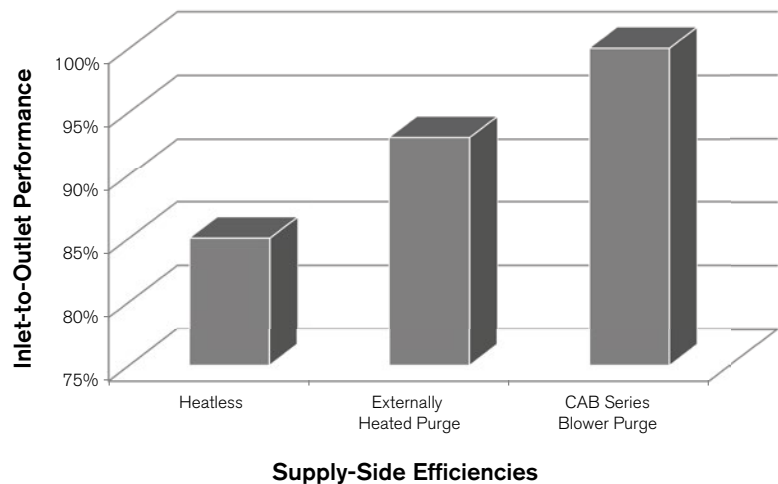

Based in Charlotte, North Carolina, SPX FLOW is a leading global supplier of highly engineered flow components, process equipment and turn-key systems, along with the related aftermarket parts and services, into the food and beverage, power and energy and industrial end markets. SPX FLOW has more than \$2 billion in annual revenues and approximately 8,000 employees with operations in over 35 countries and sales in over 150 countries around the world. To learn more about SPX FLOW, please visit our website at [www.spxflow.com](http://www.spxflow.com)

### DEMAND-SIDE IMPACT ON SUPPLY-SIDE DRYER TYPES

Plant Air Demand scfm	Dryer Types Efficiency	Air Volume Required to Meet Demand scfm	Air Compressor Needed to Meet Air Volume		Compressed Purge Air Penalty <sup>1</sup> Dollars	Preferred Supply-Side Solution
			HP	scfm		
1000	Blower Purge (100%)	1,000	200	1,000	\$0	Yes
1000	Heated Purge (93%)	1,075	250	1,250	\$11,436	No
1000	Heatless (85%)	1,176	250	1,250	\$24,506	No

<sup>1</sup>Assumes 5 scfm per HP, 8760 hours of operation per year, 10 cents per kW/h

## How It Works

Moist, filtered compressed air enters down flow drying Chamber 1 via valve (A). Water vapor is adsorbed onto the desiccant and dry compressed air exits through valve (B) where, abrasive desiccant dust is captured by a high-temperature afterfilter. In regeneration mode, atmospheric air is drawn through a muffler/filter and compressed by a multi-stage centrifugal blower (C). Balanced heat distribution in Chamber 2 comes from natural heat-of-adsorption and an external, low watt density heater (D). Blower discharge flows through the heater, through valve (F) and then through the desiccant bed. Water vapor releases from the heated desiccant and evacuates through valve (E). Once desorbed, the heater and blower turn off and the bed is allowed to cool. Finally, valves (E) and (F) close and Chamber 2 is repressurized through valve (G). No further energy will be consumed until AMLOC® determines the on-line bed is fully utilized. Whereupon, operations will switch and Chamber 1 will be regenerated.

AMLOC® governs this process with precision. The capacitance probes sense the dielectric strength water vapor imparts on the desiccant. Low moisture loads extend the drying cycle while eliminating energy use. Fewer flow reversals and minimal thermal stress yields longer desiccant and valve life. Serious performance, reliability and energy savings result as energy consumption mirrors plant air usage.

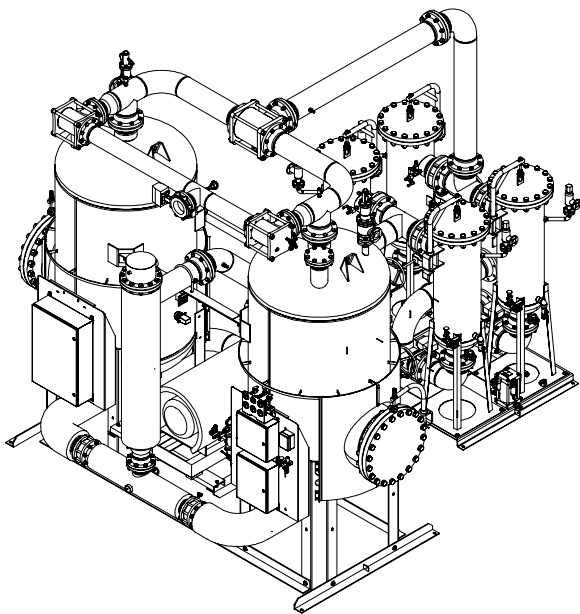

## CAB Series Flow Diagram

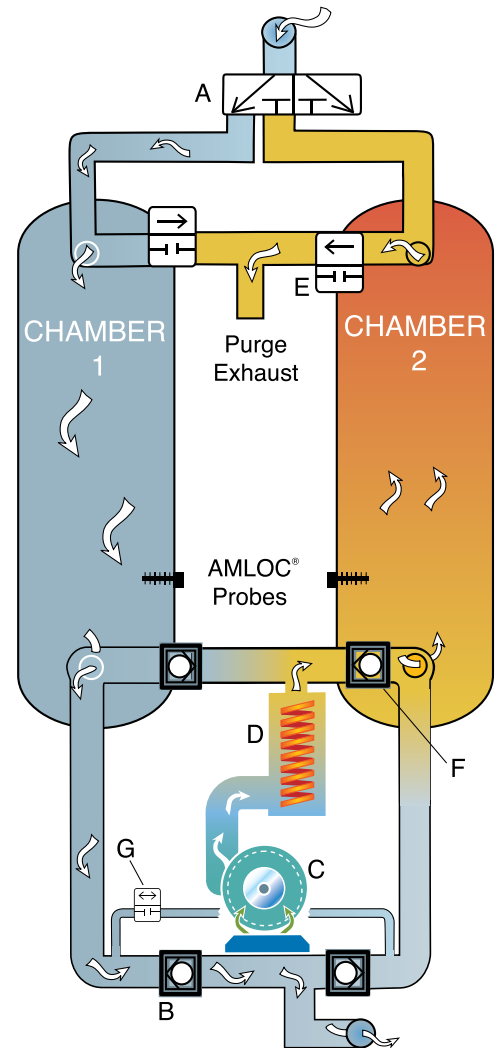

# CAB Series – Key Product Features



## Sensory Perception

- AMLOC® Probe proven in over 25,000 installations.
- Lifetime Warranty. No calibration required.

## Engineered Performance

Non-lubricated Century Series valves.  
The ULTIMATE in reliability

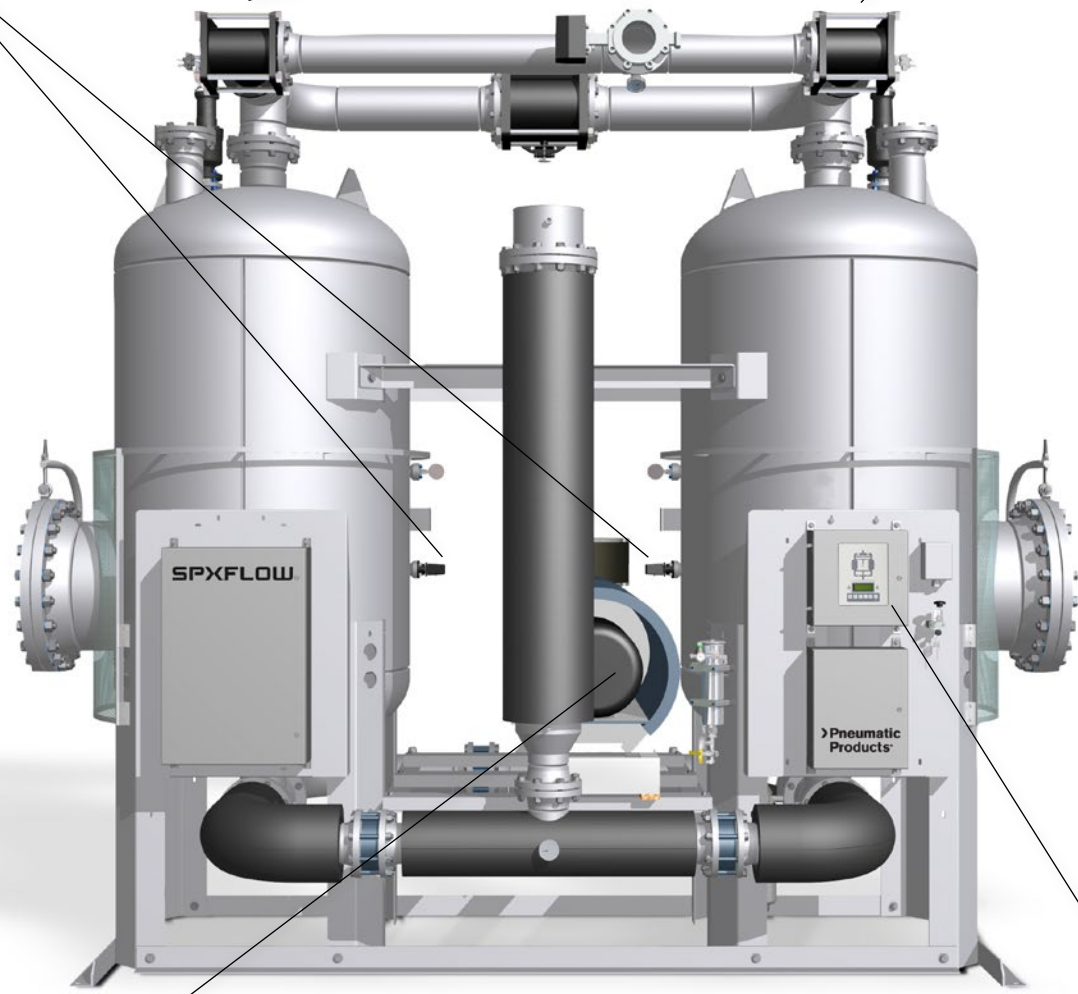
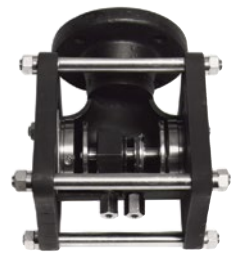

## Energy Efficient

Multi-stage centrifugal blowers to deliver superior energy efficiency.

\*1200CAB - 2500CAB Regenerative blowers

## AMLOC® Energy Optimizer Synoptic indication of process phases.

RS-485 connection providing MODBUS RTU communication or Ethernet connection providing MODBUS TCP communication available. 4 line X 80 character information center.



\*Model Shown with Optional Features

## Exclusive Feature Details

---

### PROCESS QUALITY VALVES – ENGINEERED SIMPLICITY

Standard off-the-shelf valves under performed on critical air dryer applications so we engineered our own. Tested under adverse conditions without failure in excess of 500,000 cycles, our full port, air-operated Century Series poppet valves feature stainless steel internals. To protect against wear, a friction-free PTFE coating is applied to all wear surfaces. Corrosion resistant and non-lubricated, these valves were engineered to withstand elevated temperatures, clogging and erosion caused by abrasive desiccant dust. These are the best valves in the industry - period.

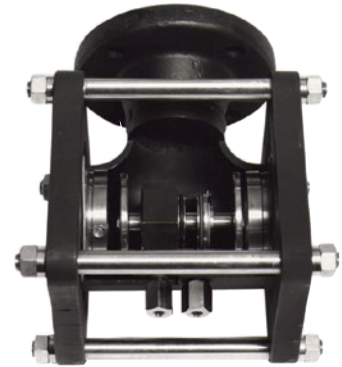

### SMarT ADC CONTROL SYSTEM

The SMarT ADC is an update to our time tested, user-friendly electronic synoptic controller for heatless dryer applications. The SMarT ADC builds upon the success of the legendary ADC control system adding new and innovative features.

The SMarT ADC Controller utilizes dual micro-processors to provide advanced communications and improved analog sensor support. The application processor provides the control functions and advanced communications options. The analog microprocessor performs the analog processing tasks including taking readings from various process sensors and communicating this data to the application processor. The application processor is a new microcontroller that has the built-in capability to communicate via Ethernet. This capability can be used to communicate over factory ethernet connections and the internet. This connection allows users to remotely monitor via the web interface their equipments performance, diagnostics, and status indicators.

Additional communications compatibility is provided via the RS-485 connection allowing the controller to communicate with ModBus applications.



### AUTOMATED MOISTURE LOAD CONTROL (AMLOC®):

Today's air system auditors know that it is rare to find a dryer operating at full-load conditions. That is why AMLOC® is standard equipment on every CAB Series dryer we build. AMLOC® Energy Management Systems generate tens-of-thousands of dollars in energy savings annually for industry leaders. Our PTFE coated stainless steel capacitance probes sense the dielectric strength imparted upon the desiccant by the extracted water vapor. The moisture sensing of AMLOC automatically manages the drying cycle and becomes a tool identify aging or fouled desiccant beds, while ensuring constant dewpoint performance.



# Exclusive Feature Details Continued

## PCC & PCS SERIES FILTRATION

Critical applications and hostile environments demand premium grade products. Global industry leaders rely on PCS & PCC Series filters for their unmatched quality, durability and reliability in tough applications. PPC's large flow filters meet the challenge and provide contaminant protection for the premium grade desiccants used in our dryers as well as contaminant sensitive applications. Power plants, paper mills, refineries, and petro-chemical installations are a few examples of the challenging environments that rely on PPC filters for lasting protection.



## Product Feature List

### AMLOC® Energy Management System

PTFE coated, stainless steel capacitance sensor	Standard
---	----------

### Desiccant:

Premium Grade Activated Alumina	Standard
---------------------------------	----------

### Moisture Indicator

Aquadex® Visual, Color Change	Standard
-------------------------------	----------

### ADC Control System w/ AMLOC® Intelligence

Energy Management System - Automatic Savings	Standard
Extended drying cycles - long component life	Standard
RS-485 port- communications capable	Standard
Operational History Log Stores 20 Events - Simplifies Trouble-Shooting	Standard
Synoptic display with active flow path illumination LEDs	Standard
Class 1, Groups C & D, Division II	Optional

### Information Center

Back-lit LCD - Visual Clarity In Diverse Lighting Conditions	Standard
4 categories: Dryer Status, Service, History, Configuration	Standard
Warning & Alarm Lights	Standard

### Alarm Protection Parameters:

Alarm Failures: Depressurization Repressurization On-line Pressure, Thermocouple, Heater Over-Temperature	Standard
Warning: AMLOC® Failure, High Humidity	Standard
Service Reminders: Valves, Desiccant, Filters	Standard

# Product Specifications

DRYER MODEL	INLET <sup>1,2</sup>		HEATER RATED OUTPUT KW	TOTAL FLA	DIMENSIONS <sup>3</sup> INCHES			APPROX <sup>3</sup> WEIGHT LB	INLET/OUTLET <sup>3</sup> CONNECTIONS IN	MOUNTED FILTRATION	
	FLOW SCFM	BLOWER HP			H	W	D			PREFILTER	AFTERFILTER
<b>1200CAB</b>	1,238	7.5	26	43.6	139	83	95	4,550	3 FLG	PCC114003SU	PCC114003HT
<b>1600CAB</b>	1,592	10	38	54.2	128	99	98	6,050	3 FLG	PCC118003SU	PCC118003HT
<b>2000CAB</b>	1,951	10	40	64.2	183	94	112	7,280	4 FLG	PCC124004SU	PCC124004HT
<b>2500CAB</b>	2,312	15	44	76.2	155	99	106	8,290	4 FLG	PCC124004SU	PCC124004HT
<b>3000CAB</b>	2,806	15	56	91.3	148	116	117	10,590	4 FLG	PCC136003SU	PCC136003HT
<b>4000CAB</b>	3,815	10	77	110.6	162	127	129	15,650	6 FLG	PCC148004SU	PCC148004HT
<b>5000CAB</b>	5,006	20	100	152.5	164	143	139	18,770	6 FLG	PCC160005SU	PCC160005HT
<b>6000CAB</b>	6,216	25	117	180.9	172	176	153	23,570	6 FLG	PCC172006SU	PCC172006HT
<b>7000CAB</b>	7,387	40	141	229.0	184	174	162	26,400	8 FLG	PCC172006SU	PCC172006HT
<b>9000CAB</b>	9,143	30	174	258.4	187	198	166	31,590	8 FLG	PCC196008SU	PCC196008HT
<b>10000CAB</b>	11,097	50	208	326.1	190	204	184	37,610	8 FLG	PCC11600015SU	PCC11600015HT
<b>12000CAB</b>	12,915	75	236	392.2	207	204	190	42,130	10 FLG	PCC11600015SU	PCC11600015HT

<sup>1</sup> @ 100 psig, 100°F -40°F Pressure Dewpoints

<sup>2</sup> Performance data per CAGI Standard ADF 200 for Dual-Tower Regenerative Desiccant Compressed Air Dryer. Rating conditions are 100°F (37.8°C) inlet 100 psig (6.9 bar) inlet pressure, 100% relative humidity, 100°F (37.8°C) ambient temperature.

<sup>3</sup> Dimensions, weights & Inlet/outlet connections based on F01 pre-piped filter configuration.

Consult factory for sizing assistance and -100°F pressure dew point applications. Larger models available.

