

Duplex H-Type Strainer

8" – 36" NB

Duplex H-Type Strainer 8" – 36" (200 mm – 900 mm)

The Duplex H-Type strainers are designed for larger size applications where interruption of the flow for basket cleaning is not permitted. This range of duplex strainers employs a simple method for changeover, using two sliding gate valves, operated manually by screwed shafts via an external handwheel. Operating shafts are interconnected for simultaneous operation, thus eliminating any possibility of completely shutting off the liquid flow. Provided with a valve position indicator showing which chamber of the filter is on stream. Access to the filter baskets is through quick release covers. The lightweight baskets are quickly and easily removed for cleaning without the need for any tools, lifting gear or specialised knowledge and with minimum down time operation.

STANDARD FEATURES

- Multiple lightweight baskets for easy handling
- Sliding gate type valves with positive compression seating
- Stepped angled basket seat for minimum pressure drop and positive basket seating
- Robust basket support cages complete with replaceable mesh inserts (when required) reducing spares holding and operating costs
- Quick release covers for convenient basket removal without the need for tools or lifting gear
- Resilient cover 'O' seals
- Filtration — 2 mm dia. perforations down to 45 microns (coarser filtration available)
- External valve position indicator showing which chamber is on stream
- Replaceable valve seats
- Synchronised chain drive
- Standard in cast iron and cast steel, all fitted with baskets and inserts as required

- External pressure equalising valve
- Flanged to ASME Class 250FF and Class 300RF, can be drilled to ASME Class 150, BS tables and DIN standards

OPTIONS

- Internal protective coatings
- Automatic valve changeover operation
- Cathodic protection for seawater service
- Reinforced baskets to withstand high differential pressures
- Automatic backflushing facilities for both suction and discharge duties
- Magnetic element assemblies
- Pleated baskets for higher filtration area
- DP gauges and switches
- Flanged vents and drains

SPECIALS

- Cast or fabricated units for higher working pressures



DESIGN DATA

CAST IRON BS 1452 GR 220			CAST STEEL ASTM A216 WCB		
FLANGE RATING	DESIGN PRESSURE	WORKING TEMP	FLANGE RATING	DESIGN PRESSURE	WORKING TEMP
ANSI 250 FF	10.3 BARG (150 PSIG) @ 38°C	0°C - 100°C	ANSI 300 RF	20 BARG (300 PSIG) @ 38°C	0°C - 100°C

STANDARD INTERNALS

SERVICE	MATERIALS				
	VALVES	SHAFTS	VALVE SEATS	DRIVE NUTS	BASKET
OIL	CAST IRON BS1452 ~ 260	MILD STEEL BS970 ~ 070M20	CAST IRON BS1452 ~ 260	CAST IRON BS1452 ~ 260	MILD STEEL BS970 ~ 070M20 OR STAINLESS STEEL AISI 316L
FRESH WATER	CAST IRON BS1452 ~ 260	STAINLESS STEEL BS970 ~ 316S16	CAST IRON BS1452 ~ 260	CAST IRON BS1452 ~ 260	STAINLESS STEEL AISI 316L
SEA WATER	GUNMETAL BS1400LG4	STAINLESS STEEL BS970 ~ 316S16	GUNMETAL BS1400LG4	GUNMETAL BS1400LG4	STAINLESS STEEL AISI 316L OR MONEL 400

DIMENSIONS

SIZE		MODEL NO.	NO. OF BASKETS	A MM	B MM	C MM	D MM	E MM	F MM	GROSS BASKET AREA (PER CHAMBER) CM ²	WEIGHT	
IN	MM										LB	KG
8	200	HN-8	2	1000	419	902	238	568	692	3225	2756	1250
10	250	HS-10	2	1089	610	1112	447	606	738	5160	3086	1400
10	250	HL-10	4	1502	457	1067	451	619	838	7485	4960	2250
12	300	HN-12	4	1502	457	1067	451	619	838	7485	4960	2250
14	350	HS-14	4	1502	457	1067	451	619	838	7485	4960	2250
14	350	HL-14	4	1743	781	1473	769	762	1067	12905	10384	4710
16	400	HN-16	4	1743	781	1473	769	762	1067	12905	10384	4710
18	450	HN-18	4	1743	781	1473	769	762	1067	12905	10384	4710
20	500	HS-20	4	1743	781	1473	769	762	1067	12905	10384	4710
20	500	HL-20	8	2410	870	1635	830	1240	1565	25805	19621	8900
24	600	HS-24	8	2410	870	1635	830	1240	1565	25805	19621	8900
24	600	HL-24	12	2600	870	1700	1220	1525	1800	38710	20657	9370
28	700	HN-28	12	2600	870	1700	1220	1525	1800	38710	20657	9370
30	750	HN-30	12	2600	870	1700	1220	1525	1800	38710	20657	9370
32	800	HN-32	12	2600	870	1700	1220	1525	1800	38710	20657	9370
36	900	HN-36										

DETAILS ON APPLICATION

Approximate dimensions only. Tolerance: Plus or Minus 3 mm

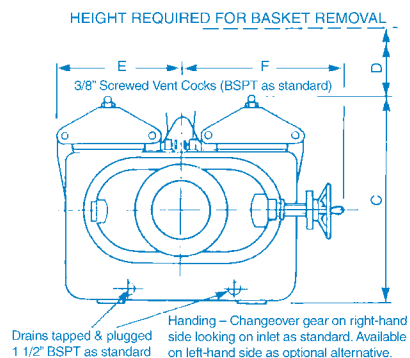
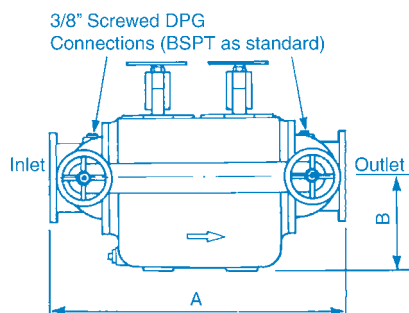

SPX

SPX Flow Technology, SPX International Ltd, Hambridge Road, Newbury, Berkshire RG14 5TR
 Phone: +44 1635 42363 Fax: +44 1635 49758 E-Mail: plentyfilters@spx.com
 For more information about our worldwide locations, approvals, certifications, and local representatives,
 please visit www.plentyfiltration.net

SPX reserves the right to incorporate our latest design and material changes without notice or obligations.

Design features, materials of construction and dimensional data, as described in this bulletin, are provided for your information only and should not be relied upon unless confirmed in writing. Please contact your local sales representative for product availability in your region. For more information visit www.spx.com.

"The green ">" is a trademark of SPX Corporation, Inc."