

# Duplex D-Type Strainer

1" – 4" NB

## D-Type Dual Basket Strainer 1" – 4" (25 mm – 100 mm) NB

Duplex strainers are used for pipelines operating continuously incorporating twin chambers each rated for 100% capacity. An integral flow changeover valve permits basket removal and cleaning without interruption of flow. This range is designed to compliment the Simplex filters but allows the cleaning and replacement of baskets to be carried out without any interruption to the flow through the filter. Fixed stops are provided to indicate which basket is in use. A projecting flange from the changeover handle guards the cover of the basket in use, making it impossible to remove inadvertently.

### STANDARD FEATURES

- Single lever action on changeover valve eliminates possibility of hydraulic lock and accidental interruption of the flow
- Fixed stops are provided to indicate which chamber is in use and a projecting flange from the valve lever guards the cover of the chamber in use to avoid the wrong cover from being inadvertently opened
- Quick release covers eliminate the need for tools for maintenance
- Basket area to pipe CSA of over 12:1
- Designed for pressure ratings up to ASME class 300 (51 BARG)
- Flow is from inside to outside of the basket to trap and retain debris
- Supplied with coarse perforated baskets (2mm as standard) or fine stainless steel inserts to give particle retention down to 45 microns

### OPTIONS

- Pleated baskets for high filtration areas.
- Reinforced baskets for withstanding high differential pressures.
- Magnetic element assemblies.
- Flanged connection for drain, vent and ancillary connections.
- Steam, hot water or oil jackets.
- Supplied with ancillary equipment such as DP gauges and switches, valves for drains and vents.
- Available in gunmetal, duplex stainless steel or other special alloys.



## DESIGN DATA

CAST IRON BS 1452 GR 220			CAST STEEL ASTM A216 WCB			STAINLESS STEEL BS 1504 316 C16		
FLANGE RATING	DESIGN PRESSURE	WORKING TEMP	FLANGE RATING	DESIGN PRESSURE	WORKING TEMP	FLANGE RATING	DESIGN PRESSURE	WORKING TEMP
ANSI 250 FF	17.2 BARG (250 psig) @ 38°C	0°C - 120°C	ANSI 300 RF	51 BARG (740 psig) @ 38°C	0°C - 200°C	ANSI 300 RF	51 BARG (740 psig) @ 38°C	0°C - 200°C

All Baskets and Mesh Inserts Stainless Steel AISI 316

Bridge on SS filter is Cast Steel – (Non Contact Part)

## DIMENSIONS

SIZE		MODEL NO.	A MM	B MM	C MM	D MM	E MM	F MM	G BSPT	H BSPT	J BSPT	K MM	WEIGHT	
IN	MM												LB	KG
1 SCR*	25	1-DA	338	229	99	86	205	106	1/8"	1/4"	1/4"	133	51	23
1 1/2 SCR*	40	1.5-DA	338	229	102	108	223	157	1/8"	1/4"	1/4"	140	84	38
1	25	1-DA	338	229	108	111	205	106	1/8"	1/4"	1/4"	133	51	23
1 1/2	40	1.5-DA	338	229	108	121	223	157	1/8"	1/4"	1/4"	140	84	38
2	50	2-DA	327	219	130	149	274	179	1/4"	1/4"	1/2"	195	119	54
3	80	3-DA	454	305	183	233	333	286	1/4"	1/4"	1/2"	268	231	105
4	100	4-DA	643	432	186	268	399	370	1/4"	1/4"	1/2"	268	447	205

\* Screwed Version in Cast Iron only - Available with BSPF or NTPF parallel threads

Bosses G & H drilled and tapped only if specified for sizes 50mm and below.

Dimension 'A' illustrates the maximum width of a valve lever swung across the filter body (where applicable).

A system of lubricating ducts is incorporated in the changeover (parallel plug) valve. This ensures that the valve is sealed against leakage and provides an inert barrier, which protects metal surfaces and reduces corrosion. The valve is sealed top and bottom by 'O' rings. The lubricant is supplied in stick form and is applied through a screw on top of the valve.

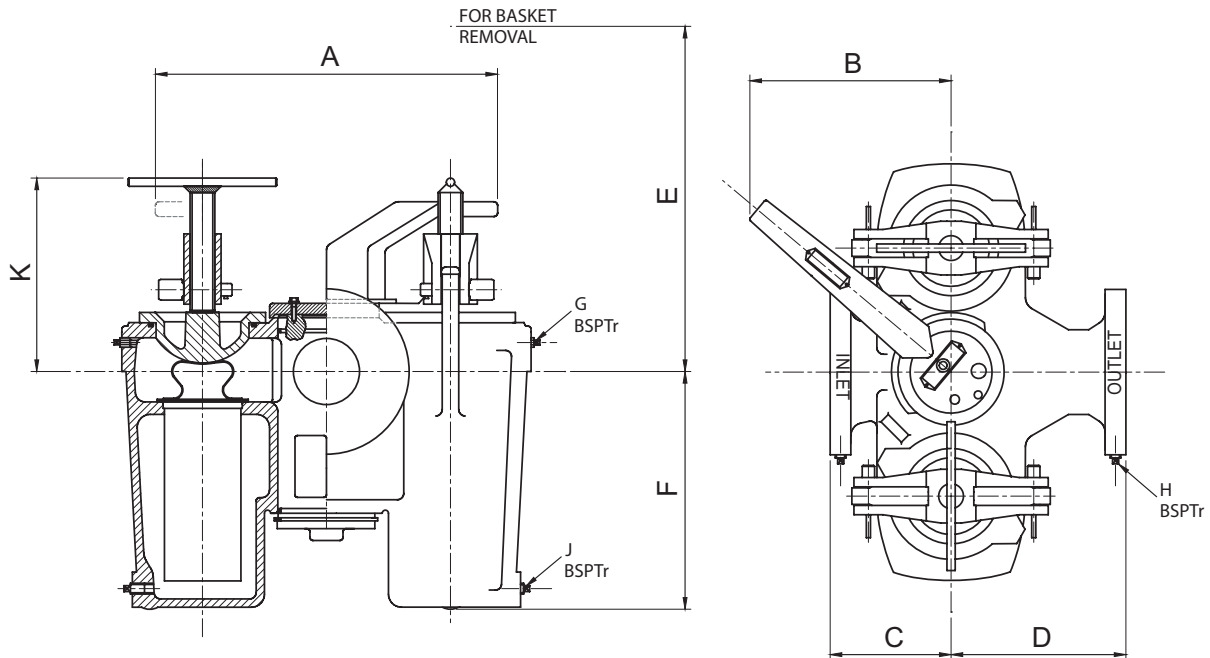

# SPX

SPX Flow Technology, SPX International Ltd, Hambridge Road, Newbury, Berkshire RG14 5TR  
 Phone: +44 1635 42363 Fax: +44 1635 49758 E-Mail: plentyfilters@spx.com  
 For more information about our worldwide locations, approvals, certifications, and local representatives,  
 please visit [www.plentyfiltration.net](http://www.plentyfiltration.net)

SPX reserves the right to incorporate our latest design and material changes without notice or obligations.

Design features, materials of construction and dimensional data, as described in this bulletin, are provided for your information only and should not be relied upon unless confirmed in writing. Please contact your local sales representative for product availability in your region. For more information visit [www.spx.com](http://www.spx.com).

"The green ">" is a trademark of SPX Corporation, Inc."

Issued: PF-32.00 -1- EN - 03/2013

COPYRIGHT © 2013 SPX Corporation

# Duplex D-Type Strainer

6" – 8" NB

## D-Type Dual Basket Strainer 6" – 8" (150 mm – 200 mm)

Duplex D-Type strainers are used for pipelines operating continuously, where a single strainer cannot be used as the flow would have to be interrupted to clean the element. Twin filtration chambers each rated for 100% capacity and two disk type changeover valves operated by interconnected screwed shafts for simultaneous operation, ensure that a filtration chamber is always in operation.

### STANDARD FEATURES

- Quick release covers for ease of basket removal without the need for tools or lifting gear
- Resilient cover 'O' seals
- Robust basket support cages complete with replaceable mesh inserts (when required) reducing spares holding and operating costs
- Fitted with 2mm perforated stainless steel basket as standard
- External valve position indicators showing which chamber is on stream
- Replaceable valve seats
- Synchronised chain drive
- External pressure equalising valve
- Stainless steel disc valves and screwed shafts
- Single basket per chamber

### OPTIONS

- Mesh inserts from 20-300 mesh available for fine filtration applications
- Alternative basket materials available
- External paint finish options
- Internal protective coatings
- Differential pressure indication / switches
- Flanged vent and drains
- Magnetic element assemblies
- Reinforced support baskets to withstand high differential pressures
- Automatic valve changeover operation

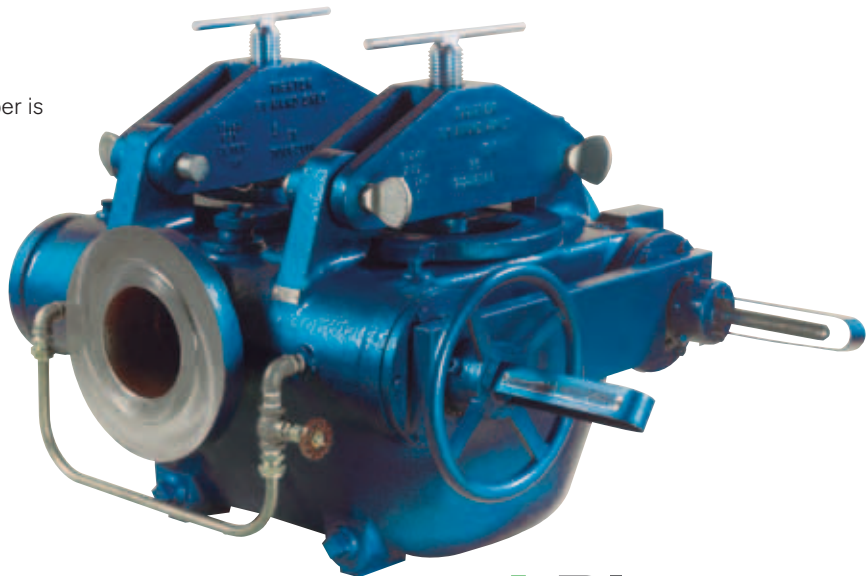

## DESIGN DATA

CAST IRON BS 1452 GR 260			CAST STEEL ASTM A216 WCB		
FLANGE RATING	DESIGN PRESSURE	WORKING TEMP	FLANGE RATING	DESIGN PRESSURE	WORKING TEMP
ANSI 125FF	10.3 BARG (150 PSIG) @ 38°C	0°C - 120°C	ANSI 150/300RF	24.0 BARG (350 PSIG) @ 38°C	0°C - 200°C

Flanges drilled to Customer requirements

All Baskets and Mesh Inserts Stainless Steel AISI 316

## DIMENSIONS

SIZE		MODEL NO.	NO. OF BASKETS	A MM	B MM	C MM	D MM	E MM	F BSPT	WEIGHT	
IN	MM									LB	KG
6	150	6-DA	2	835	343	699	401	705	1½"	1003	454
8	200	8-DA	2	1016	343	788	401	705	1½"	1342	608

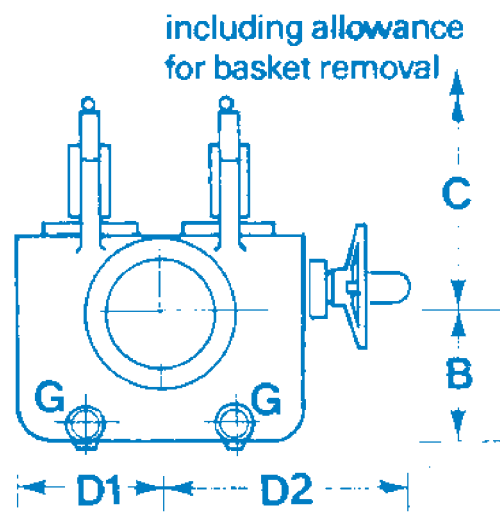
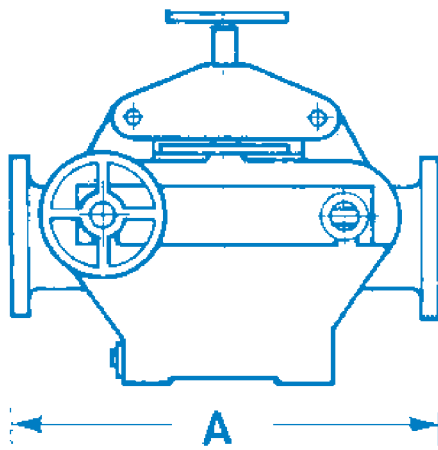

# SPX®

SPX Flow Technology, SPX International Ltd, Hambridge Road, Newbury, Berkshire RG14 5TR  
 Phone: +44 1635 42363 Fax: +44 1635 49758 E-Mail: plentyfilters@spx.com  
 For more information about our worldwide locations, approvals, certifications, and local representatives,  
 please visit [www.plentyfiltration.net](http://www.plentyfiltration.net)

SPX reserves the right to incorporate our latest design and material changes without notice or obligations.

Design features, materials of construction and dimensional data, as described in this bulletin, are provided for your information only and should not be relied upon unless confirmed in writing. Please contact your local sales representative for product availability in your region. For more information visit [www.spx.com](http://www.spx.com).

"The green ">" is a trademark of SPX Corporation, Inc."