

Building connections that last™

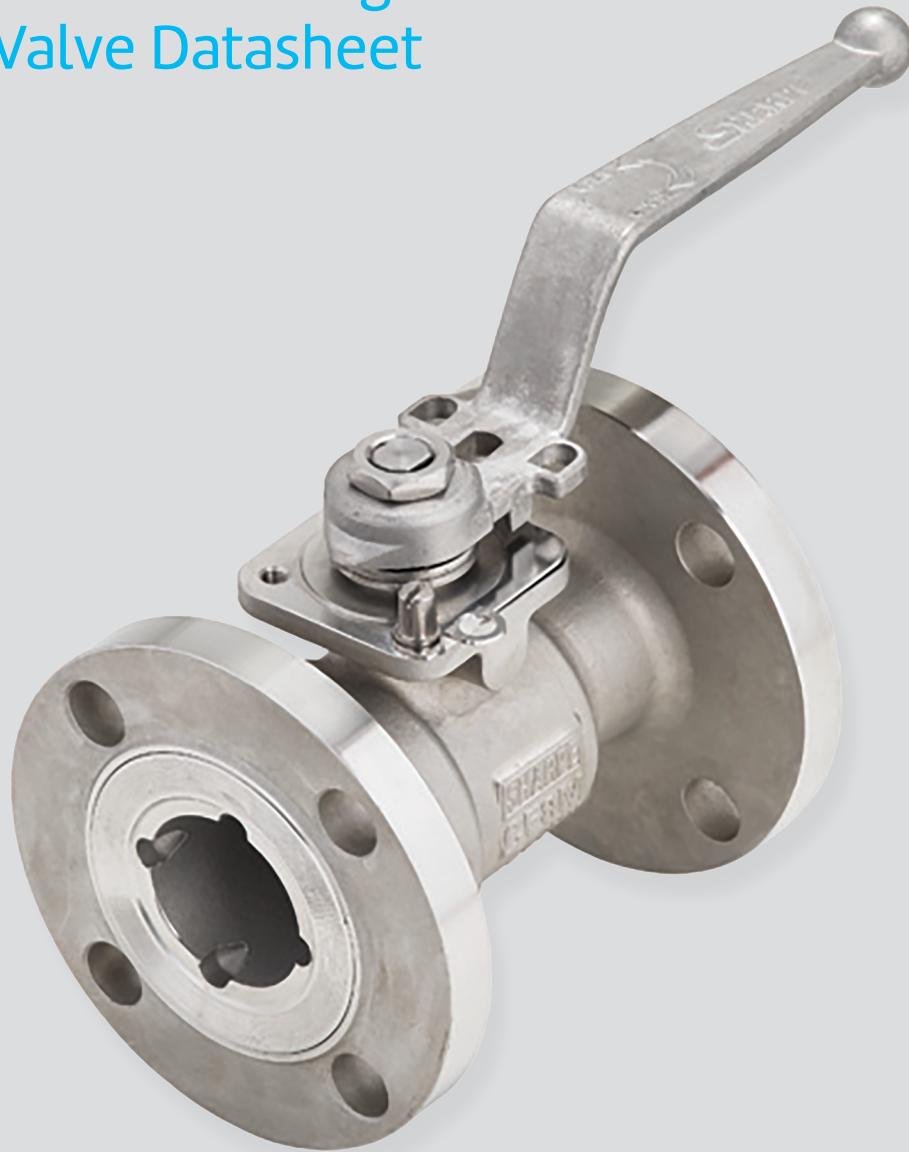

Sharpe® Series 74/FS74

High Performance Flanged Standard
Port Ball Valve Datasheet



High Performance Flanged Standard Port Ball Valve

Sharpe® Series 74/FS74



Fully Compliant
API 608 5th Edition
Class 150 | 300
API 607 6th Edition

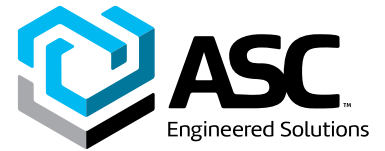

Unique Handle

A unique cast stainless steel handle specially designed to accommodate locking devices and high operating torques. A comfortable, ergonomic, non-slip, hand grip design. Handle length according to API 608 requirements.

Tamper Proof Locking Device

All Sharpe® Valves come standard with a lockable handle. The optional, Sharpe® exclusive, tamper proof locking device cannot be removed with a lock in place. When not being used with a lock its springs ensure the locking device snaps into place in the open or closed position to prevent accidental operation.

Stem Sealing

Increased Stem Sealing Area

Allows for a range of sealing combinations for severe applications and other stringent design demands.

Live-Loaded Stem

Two pairs of concave and opposing spring washers provide additional compensation for seal wear.

Safe Design

Blowout proof stem ensures the stem cannot be blown out by accidental medium pressure rise.

Wear Resistance

The thrust washer is either metallic for higher temperatures and wear resistance, or PEEK for lower temperatures.

Anti-Static

Static build-up discharges by anti-static device in stem or the metallic thrust washer.

Stem Assemblies

Various stem assemblies are available based on application requirements.

Standard – a multiple pack of Chevron “V” shaped stem seals for better sealing in TFM® or Nova materials.

High Temperature – double pack of flexible graphite seals for sealing under high temperature conditions.

Fugitive Emission – Two-pack stem seals in PTFE or graphite, with lantern ring to allow leak detection through the emission port(s).

High Cycle – unique design for demanding high cycle applications that consist of multi-system sealing devices in the stem bonnet.

Stem Trim for Sizes Greater Than 3" –

According to API 608 all valve sizes greater than 3" have an adjustable packing gland with thru bolt holes. Gland bolts pass through the holes and thread to the valve body. The position stops are bolted to the body and are not integral to the packing gland, gland flange or gland bolting.

Rugged Body

Rugged body, (316 Stainless Steel, Carbon Steel, or Alloy 20) with higher and deeper stem packing area to allow for more stem seals. Two cast bosses for optional fugitive emission ports. Larger ISO 5211 bolt pattern for handling higher valve torques.

Heavy Duty Stem Design

Stem diameters have been increased to meet the higher torque requirements of the most demanding applications. Stem to ball contact area is wider and larger, allowing the valve to be used for higher torque applications. Design allows for the use of 316 stainless steel stem material, rather than 17-4PH, for superior corrosion resistance.

Floating Ball Design

Solid stainless steel ball with wide selection of configurations for a variety of applications including; diverting, mixing, controlling, flushing, purging and more. Floating ball seals on the downstream seat, reducing torque and assuring a bubble-tight shutoff.

ISO 5211 Top-Works Compatibility

The top-works offer compatibility for mounting a wide range of accessories. Sharpe® actuators and accessories may be retrofitted on existing valves without disruption of line integrity.

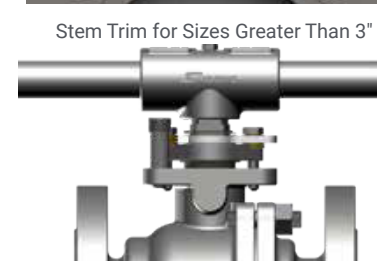
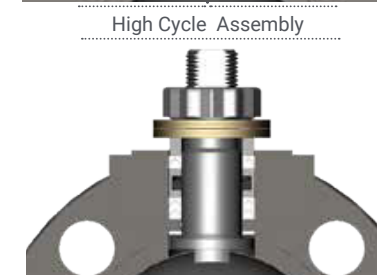
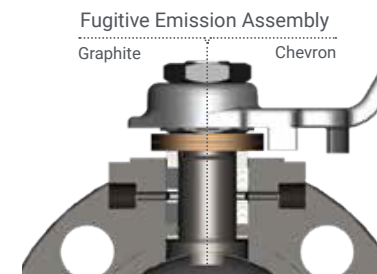
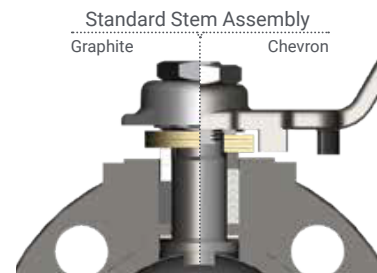

Stem Trim for Sizes Greater Than 3"



High Performance Flanged Standard Port Ball Valve

Sharpe® Series 74/FS74

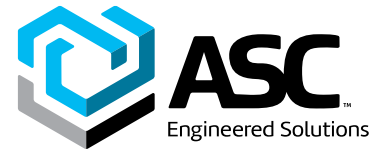

Accessories:

Integrated Fugitive Emission Ports

One or two ports can be drilled and tapped into our specially designed body. Ports align with a lantern ring precisely located between an upper and lower set of stem packing to allow monitoring of emissions.

Lockable Stem Extension

An option to move the valve top interface away from the pipe line to accommodate insulation.

Tamper Proof Locking Device

Upgrade from the standard locking device found on all Sharpe® Valves to our unique spring loaded Tamper Proof Locking Device.

Spring Return Handle

Spring return handle ensures that the valve cannot be left open (or closed).

Cast Mounting Brackets

Cast stainless steel brackets with hole patterns conforming to ISO 5211 on top and bottom for actuation mounting.

Safety locking holes for securing valves during maintenance (requires special coupler).

Aesthetic design offers wide tool clearance for installation and open visual.

Steam Jackets

Steam jackets enables the valves to be kept at a controlled temperature.

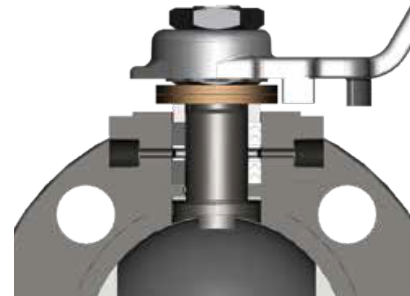

High Performance Flanged Standard Port Ball Valve Sharpe® Series 74/FS74

Series 74/FS74

1" - 2"

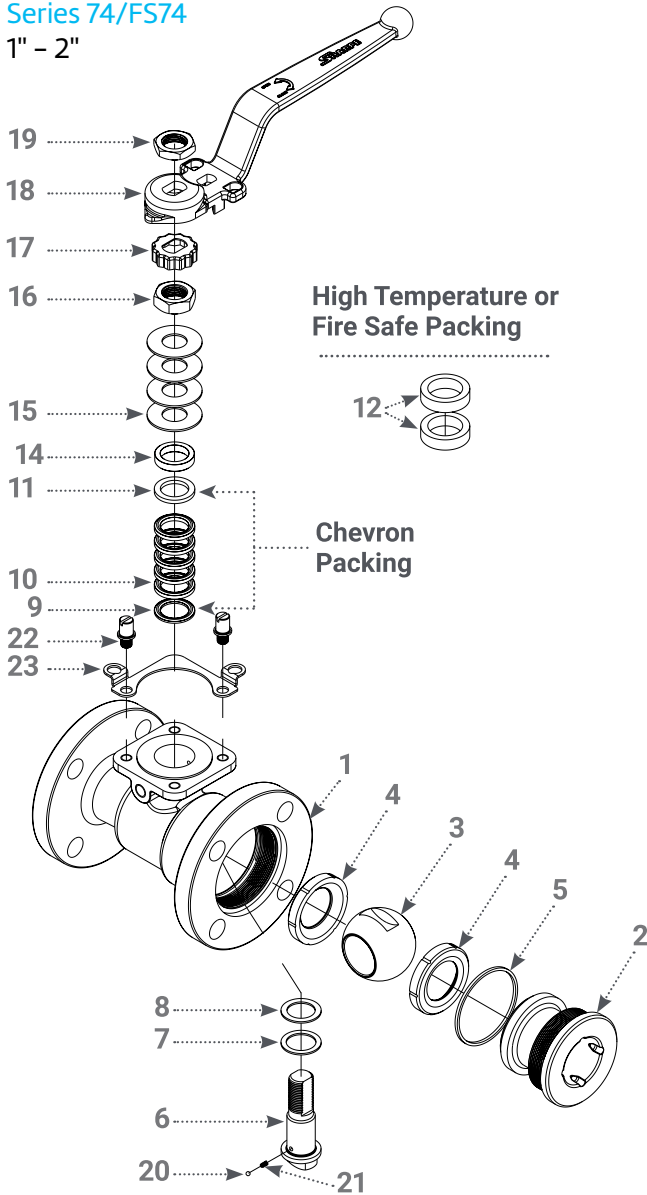

Fugitive Emission Monitoring with Lantern Ring Packing

Chevron

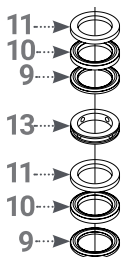

High Temperature or Fire Safe

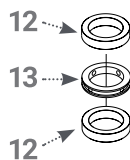

Parts & Materials Sizes 1" - 2"

Item	Description	Material	Qty.
1	Body	Carbon Steel ASTM A216 WCB 316 Stainless Steel ASTM A351 CF8M Alloy 20 ASTM A351 CN7M ***	1
2	End Piece	Carbon Steel ASTM A216 WCB 316 Stainless Steel ASTM A351 CF8M Alloy 20 ASTM A351 CN7M ***	1
3	Ball	316 Stainless Steel Alloy 20 ***	1
4*	Seat	PTFE, RTFE, TFM®, Nova, PEEK	2
5*	Body Seal	PTFE, Graphite	1
6	Stem	316 Stainless Steel 17-4PH Alloy 20 ***	1
7*	Thrust Bearing - Bottom	Nova, PEEK	1
8*	Thrust Bearing - Top	Nova	1
9*	Stem Packing - Bottom	PTFE, TFM®, Nova	2
10*,**	Stem Packing - Middle	PTFE, TFM®, Nova	2
11*	Stem Packing - Top	PTFE, TFM®, Nova	2
12*	Stem Packing	Graphite (FS or high temperature)	2
13	Lantern Ring	300 Series Stainless Steel	1
14	Gland	300 Series Stainless Steel	1
15*	Belleville Washer	17-7PH	4
16	Packing Nut	300 Series Stainless Steel	1
17	Lock Tab	300 Series Stainless Steel	1
18	Handle	304 Stainless Steel ASTM A351 CF8	1
19	Handle Nut	300 Series Stainless Steel	1
20	Anti - Static Ball	300 Series Stainless Steel	1
21	Anti - Static Spring	Hard Drawn Stainless Steel	1
22	Stop Pin	300 Series Stainless Steel	2
23	Lock Plate	300 Series Stainless Steel	1

Note:

The quantities listed in the stem arrangement are for fugitive emission assemblies. Standard stem assemblies carry more seals and no lantern rings.

* these parts are used in repair kits.

** middle stem packing is only used from size 1-1/2" and above.

*** Other materials available, call to discuss your special requirements.

High Performance Flanged Standard Port Ball Valve

Sharpe® Series 74/FS74

Series 74/FS74 3" - 4"

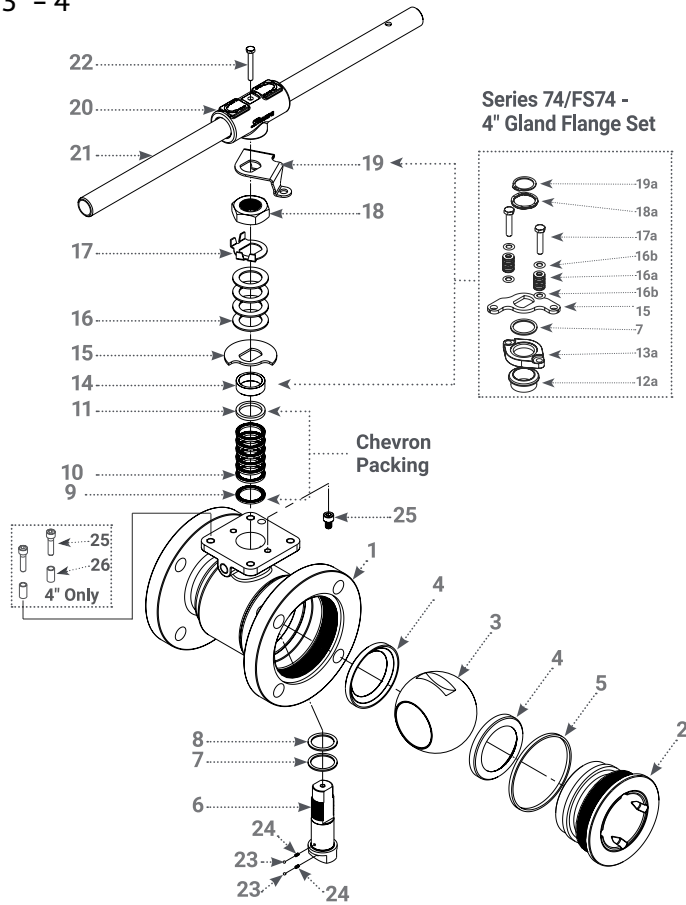

Fugitive Emission Monitoring with Lantern Ring Packing

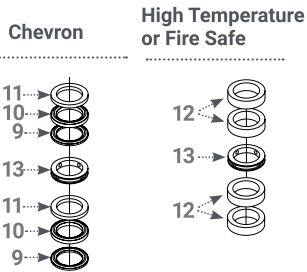

High Temperature or Fire Safe Packing

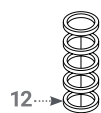

Parts & Materials 3" - 4"

Item	Description	Material	Qty.
1	Body	Carbon Steel ASTM A216 WCB 316 Stainless Steel ASTM A351 CF8M Alloy 20 ASTM A351 CN7M	1
2	End Piece	Carbon Steel ASTM A216 WCB 316 Stainless Steel ASTM A351 CF8M Alloy 20 ASTM A351 CN7M	1

Parts & Materials Continued

Item	Description	Material	Qty.
3	Ball	316 Stainless Steel Alloy 20	1
4*	Seat	PTFE, RTFE, TFM®, Nova, PEEK	2
5*	Body Seal	PTFE, Graphite	1
6	Stem	Stainless Steel 17-4PH Alloy 20	1
7*	Thrust Bearing - Bottom	Nova, PEEK	1
8*	Thrust Bearing - Top	Nova	1
9*	Stem Packing - Bottom	PTFE,TFM®, Nova	2
10*	Stem Packing - Middle	PTFE,TFM®, Nova	2
11*	Stem Packing - Top	PTFE,TFM®, Nova	2
12*	Stem Packing	Graphite (FS or high temperature)	4
12a	Gland Position Ring	300 Series Stainless Steel	1
13	Lantern Ring	300 Series Stainless Steel	1
13a	Gland (size 4" only)	316 Stainless Steel A351 CF8M	1
14	Gland	300 Series Stainless Steel	2
15	Stop Plate	300 Series Stainless Steel	1
16	Belleville Washer	17-7PH	4
16a	Belleville Washer	17-7PH	16
16b	Washer	300 Series Stainless Steel	4
17	Lock Tab	300 Series Stainless Steel	1
17a	Gland Bolt	300 Series Stainless Steel	2
18	Packing Nut	300 Series Stainless Steel	1
18a	Retainer Spring	300 Series Stainless Steel	1
19	Lock Plate	300 Series Stainless Steel	1
19a	Lock Plate	300 Series Stainless Steel	1
20	Wrench Block	304 Stainless Steel ASTM A351CF8	1
21	Handle Pipe	Stainless Steel Zinc Plated Carbon Steel	1
22	Wrench Bolt	300 Series Stainless Steel	1
23	Anti-Static Ball	300 Series Stainless Steel	2
24	Anti-Static Spring	Hard Drawn Stainless Steel	2
25	Stop Pin	300 Series Stainless Steel	1/2
26	Stop Pin Sleeve	300 Series Stainless Steel	2

Note: The quantities listed in the stem arrangement are for fugitive emission assemblies. Standard stem assemblies carry more seals and no lantern rings.

* these parts are used in repair kits.

High Performance Flanged Standard Port Ball Valve Sharpe® Series 74/FS74

Series 74/FS74

1" – 2"

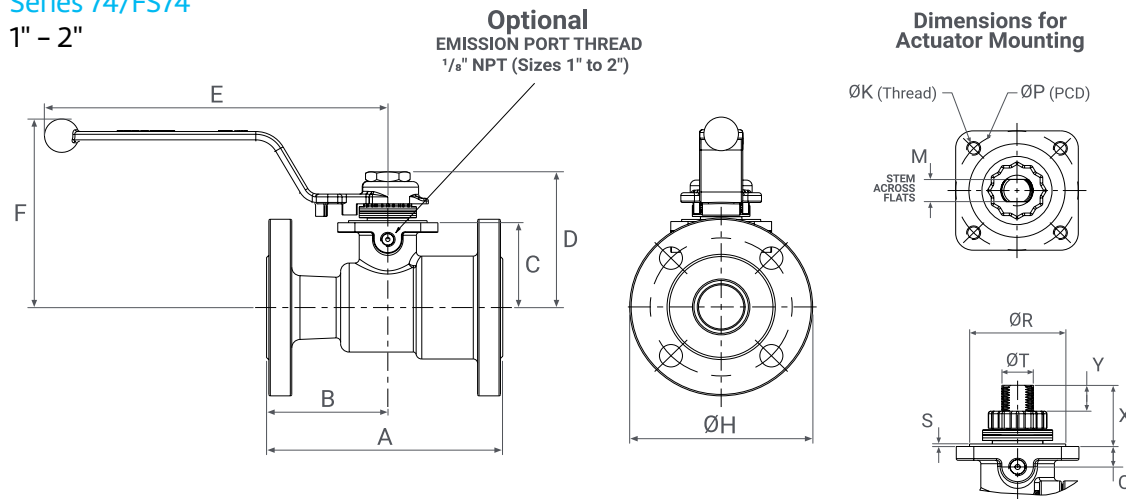

Series 74/FS74

3" – 4"

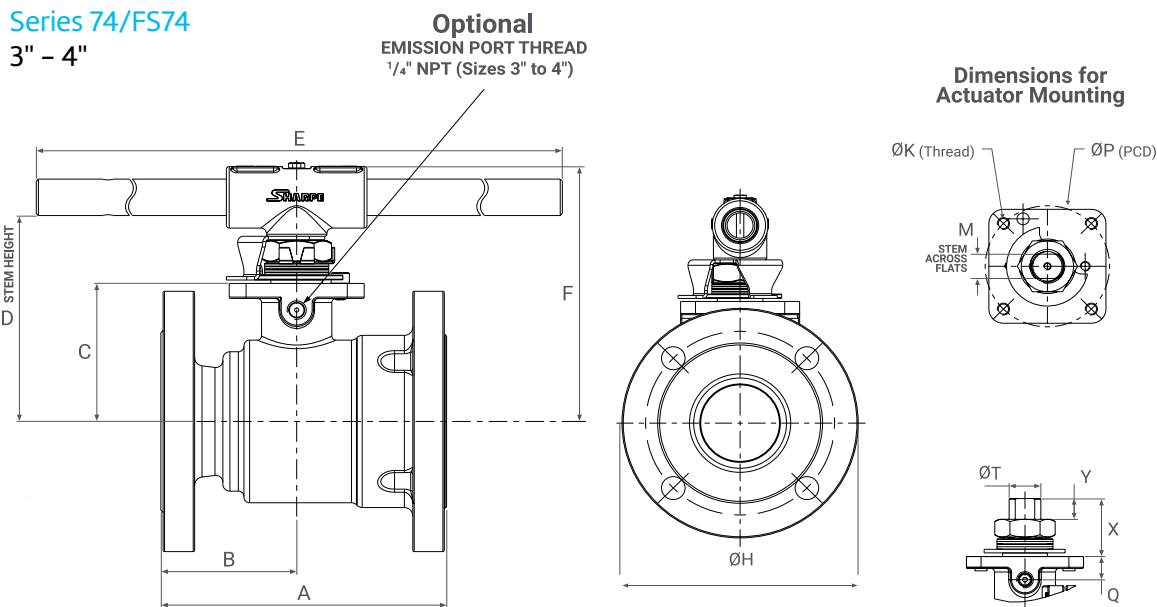

Dimensions (Inches)

Size	ØPORT	A Class 150	A Class 300	B Class 150	B Class 300	C	D	E	F	ØH Class 150	ØH Class 300	K (Thread)	M	ØP (PCD)	Q	ØR	S	ØT	X	Y
1"	0.81	5.00	6.50	2.70	2.72	1.53	2.28	6.40	3.68	4.25	4.88	M5-P0.8	0.264	F04 (1.65)	0.57	1.181	0.394	0.394	0.74	0.37
1½"	1.24	6.50	7.50	3.35	3.21	2.40	3.82	9.45	5.35	6.10	6.12	M8-P1.25	0.512	F07 (2.76)	0.47	2.165	0.059	0.709	1.41	0.54
2"	1.50	7.00	8.50	3.86	5.35	2.56	3.98	9.45	5.51	6.50	6.50	M8-P1.26	0.512	F07 (2.76)	0.47	2.165	0.059	0.709	1.41	0.54
3"	2.50	8.00	11.12	3.82	6.93	3.98	5.90	23.6	7.36	7.52	8.27	M10-P1.5	0.807	F10 (4.02)	0.77	NA	NA	1.024	1.93	0.68
4"	3.25	9.00	12.00	4.80	7.79	4.59	6.50	23.6	7.95	9.02	10.0	M10-P1.5	0.807	F10 (4.02)	0.77	NA	NA	1.024	1.93	0.68

Note:

The dimensions above are for informational purposes only. Please refer to Sharpe® Valves if you need dimensions for construction.

High Performance Flanged Standard Port Ball Valve Sharpe® Series 74/FS74

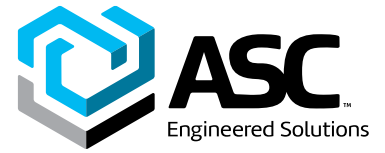

Pressure -Temperature Ratings Series 74

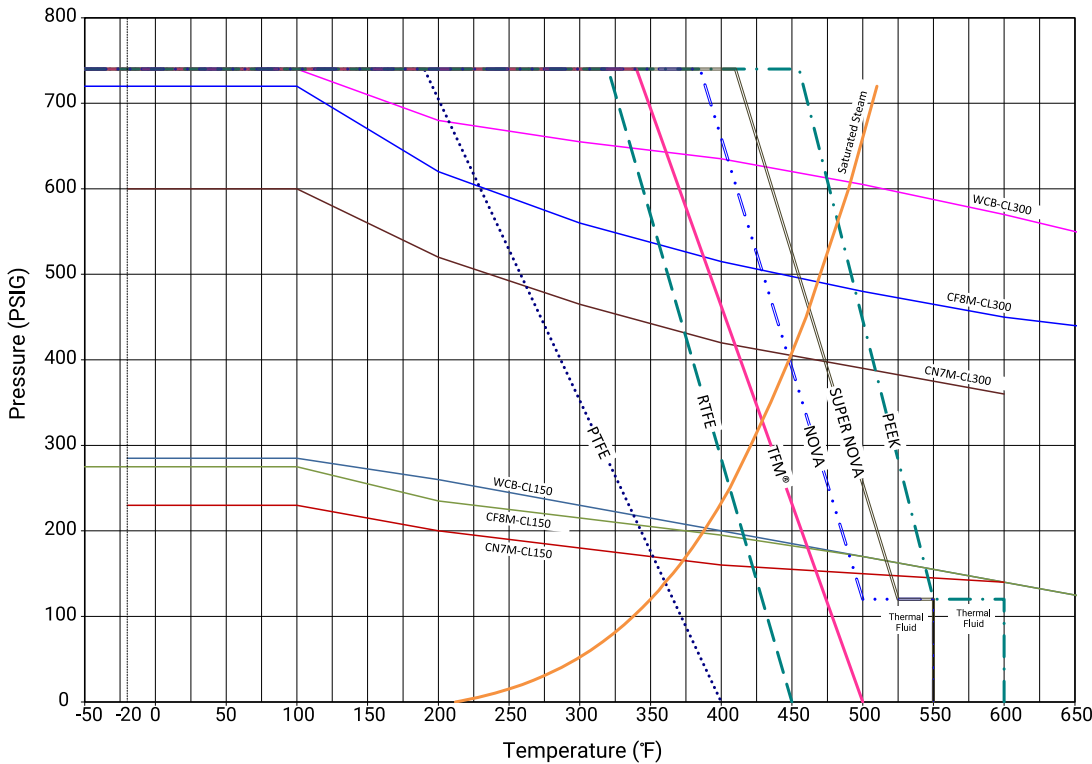

Note:

The maximum pressure/temperature ratings of the valve assemblies are limited to lowest of the body or seat material fitted.
 The valve body ratings are based on ASME B16.34 rating for materials.
 The graphs are based on laboratory testing and our experience in field.
 The seat ratings depend on the material, design, application and function.

Sharpe® Seat Materials

T - Virgin PTFE

Polytetrafluoroethylene is a Fluorocarbon-based polymer. This seating material has excellent chemical resistance and low coefficient of friction. Its temperature range is -100°F to 400°F (-73°C to 204°C). Color - white.

M - TFM® PTFE

Dyneon TFM® PTFE is a second generation PTFE with improved chemical and heat resistant properties over first generation PTFE and exhibits better stress recovery. Its temperature range is -100°F to 500°F (-73°C to 260°C) Color - white.

R - Reinforced Polytetrafluoroethylene (RTFE 15% Glass Filled). PTFE's mechanical properties are enhanced by adding filler material to provide improved strength, stability and wear resistance. Its temperature range is from -320°F to 450°F (-196°C to 204°C). Color-off-white.

N - Nova

This is a Teflon base filled with glass amorphous carbon powder and graphite. It has a lower thermal contraction/expansion than PTFE, and is ideal for steam or thermal fluid applications. Its temperature range is from -50°F to 550°F (-45°C to 288°C). Color - black.

B - Super Nova is a free-flowing compound based on TFM® containing electro-graphitized carbon. It features: increased thermal dimensional stability and surface hardness, improved deformation under load, reduced friction and wear, and good chemical stability. It has a high limiting oxygen index (LOI), low coefficient of friction, very good mechanical properties and exceptional temperature resistance. It is used as a seat material in chemical processing and automotive industries. It is ideal to use with steam and thermal fluid applications up to 550°F (288°C) and as low as -40°F (-40°C). Color - black.

P - PEEK (Unfilled) Polyetheretherketone
 PEEK Polymer offers a unique combination of chemical, mechanical and thermal properties. Excellent for water and steam applications at elevated temperatures up to 600°F (315°C). Color - beige.

Other seat materials
 Other seat material are available according to the application, such as very high temperature or cryogenic conditions.

High Performance Flanged Standard Port Ball Valve

Sharpe® Series 74/FS74

Technical Information

Valve Size	Flow Coeff. Cv	Approx. Weight Lbs	
		Class 150	Class 300
1"	30	8	11
1½"	82	18	24
2"	120	21	25
3"	350	39	49
4"	720	65	85



Applicable Standards

Wall Thickness	ASME B16.34
Face to Face Dimensions	ASME B16.10
Fugitive Emission	ISO 15848-1 (with I or N stem packing)
Flange Dimensions	ASME B16.5
Basic Design	ASME B16.34, API 608 5th Edt.
Fire Safe	API 607 6th Edt. (FS74 only)
Pressure Test	API 598, MSS-SP 72
Mounting Dimensions	ISO 5211
NACE (Only with 316 SS Stem)	MR-0175 / ISO 15156
Marking	MSS-SP 25

Notes:

TFM® is a registered trademark of Dyneon, LLC.

High Performance Flanged Standard Port Ball Valve Sharpe® Series 74/FS74

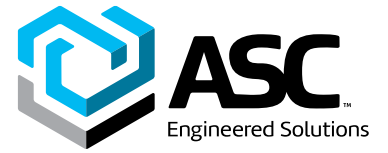

How to order Sharpe® Series 74/FS74

1"	FS74	1	-	6	6	6	R	G	G	-	1/1	-	X	-	OH
Size	Series	Class		Body/ Ends	Ball	Stem	Seat	Body Seal	Stem Packing		Ends		Service		Options

Size	Series	Body & Ends	Seat	Body Seal	Ends	Options
1"	74 Reduced Port	2 Alloy 20*	B Super Nova	G Graphite	1 Class 150 Flanged RF	OH Oval Handle*
1½"	FS74 Fire Safe	4 Carbon Steel	R RTFE 15% Glass Filled	I Impregnated Graphite	1F Class150 Flanged FF	F1 1 Emission Port
2"	Fire Safe valve must use: Graphite or Impregnated Graphite Body Seals and Stem Packing. PTFE, RTFE, TFM®, Nova, Super Nova Seats.	6 316 Stainless Steel	M TFM®	M TFM®	3 Class 300 Flanged RF	F2 2 Emission Port
3"		Ball	N Nova	T PTFE	3F Class 300 Flanged FF	L Lockable Stem Extension**
4"		Class	T PTFE	Stem Packing	Service	VB Vented Ball
	1 150	6 316 Stainless Steel	P Virgin PEEK	G Graphite	X Oxygen Service**	SJ Steam Jacket
	3 300	Stem		I Impregnated Graphite	U Vacuum	SJ3 Steam Jacket With 3 Outlets
		2 Alloy 20		M TFM®	MN Ammonia Service	TP Tamper Proof Locking Device
		6 316 Stainless Steel		N Nova	SF Silicone Free **	DMH Spring Return Handle***
		7 17-4PH		T PTFE		HC High Cycle Stem
						PN4 Packing Nut Design 4" Only

Note:
Responsibility for proper selection, use and maintenance of any product remains solely with the purchaser and end user. We reserve the right to modify or improve the designs or specifications of any product, at any time without notice. Other materials & options are available, please contact us with your requirements.

- * Up to 2"
- ** 3-1/4" up to 1", 4" on larger valves
- *** Call Sharpe® Valves for sizing / application of DMH (1" and under only)

About ASC Engineered Solutions

ASC Engineered Solutions is defined by quality—in its products, services and support. With more than 1,400 employees, the company's portfolio of precision-engineered piping support, valves and connections provides products to more than 4,000 customers across industries, such as mechanical, industrial, fire protection, oil and gas, and commercial and residential construction. Its portfolio of leading brands includes ABZ Valve®, AFCON®, Anvil®, Anvil EPS, Anvil Services, Basic-PSA, Beck®, Catawissa, Cooplet®, FlexHead®, FPPI®, Gruklok®, J.B. Smith, Merit®, North Alabama Pipe, Quadrant®, SCI®, Sharpe®, SlideLOK®, SPF® and SprinkFLEX®. With headquarters in Commerce, CA, and Exeter, NH, ASC also has ISO 9001:2015 certified production facilities in PA, TN, IL, TX, AL, LA, KS, and RI.



asc-es.com

Building connections that last™

FC-DS-SERIES 74-F574-v02 20220701

