

**Installation, Operation & Maintenance**  
**177-999 Rev J**

# **Hydra-Cell®**

## **Seal-less Pumps**

### **T100 Series Medium Pressure**

**Models: T100K and T100M**

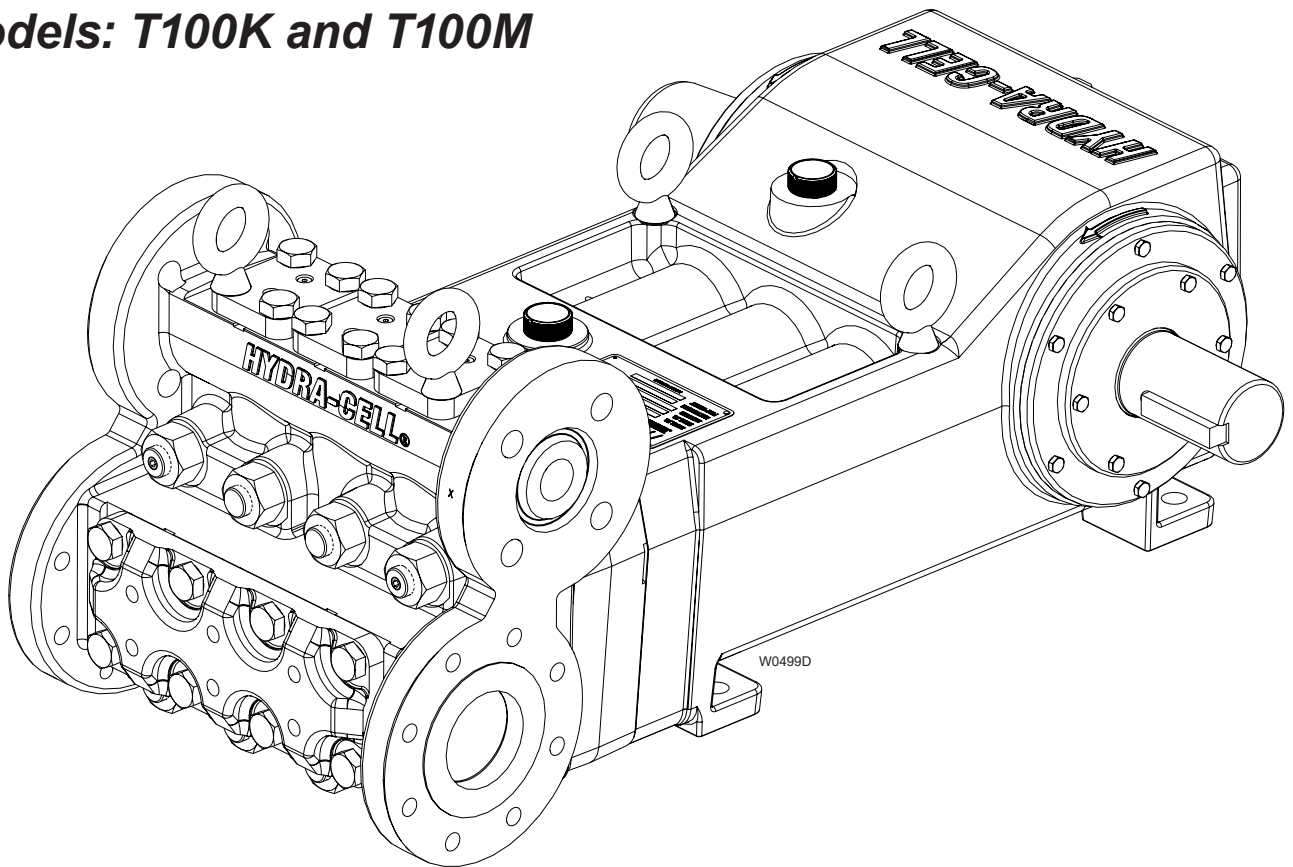

**Wanner Engineering, Inc.**

1204 Chestnut Avenue, Minneapolis, MN 55403  
Tel: (612) 332-5681 Fax: (612) 332-6937  
Toll-free fax [US only]: (800) 332-6812  
www.hydra-cell.com  
email: sales@wannereng.com



# T100 Series Medium Pressure - Contents

	Page
Component Identification .....	2
Specifications .....	2
Dimensions .....	4
Installation .....	8
Maintenance .....	12
Service (Fluid End) .....	13
Service (Hydraulic Section) .....	15
Service (Power End) .....	20
Oil Level Monitor .....	23
Torque Specifications .....	25
Fluid End Parts .....	26
Hydraulic Section Parts .....	28
Power End Parts .....	30
Troubleshooting .....	32
Tool Kit Parts .....	33
Pump Storage .....	33
Replacement Parts Kits .....	34
Warranty .....	36

## Component Identification

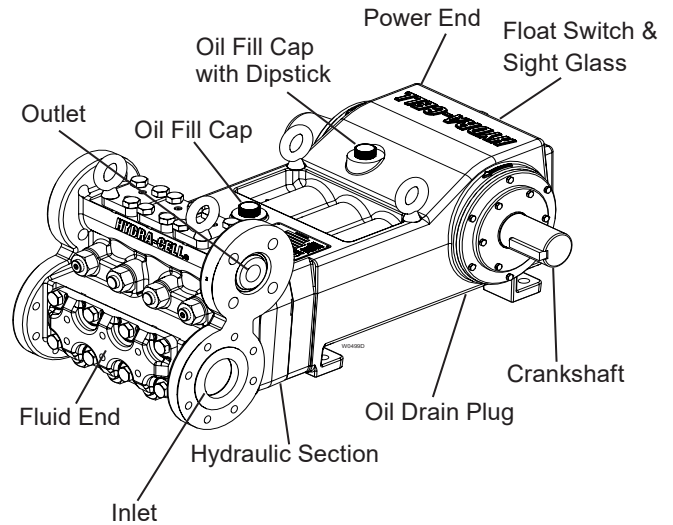

# T100 Series Medium - Specifications

<b>Maximum Pressure</b>	<b>T100K</b> 3000 psi (207 bar)			
	<b>T100M</b> 3500 psi (241 bar)			
<b>Flow Capacities @ Maximum Pressure</b>				
	<b>rpm</b>	<b>gpm</b>	<b>l/min</b>	<b>BPD</b>
<b>T100K</b>	450	45.0	170.4	1543
<b>T100M</b>	450	38.0	143.8	1302
<b>Delivery</b>				
	<b>Pressure psi (bar)</b>	<b>gal/rev</b>	<b>liters/rev</b>	
<b>T100K</b>	500 (34)	0.107	0.406	
	1500 (103)	0.105	0.397	
	3000 (207)	0.101	0.384	
<b>T100M</b>	500 (34)	0.091	0.345	
	1750 (121)	0.089	0.338	
	3500 (241)	0.086	0.327	
<b>rpm</b>	450 Maximum			
	45 Minimum (Consult factory for speeds less than 45 rpm)			
<b>Maximum Inlet Pressure</b>	500 psi (34 bar)			
<b>Operating Oil Temperature</b>	Maximum: 180° F (82.2° C)			
	Minimum: 40° F (4.4° C)			
<b>Diaphragm Material</b>	<b>Minimum Service Temperature (°C)</b>			
Aflas	77°F (25°C)			
EPDM	15°F (-9.4°C)			
FKM	15°F (-9.4°C)			
Buna-N	15°F (-9.4°C)			
(contact factory for temperatures outside this range)				

<b>Maximum Solids Size</b>	800 microns
<b>Input Shaft</b>	Left or Right Side
<b>Inlet Ports</b>	3-1/2 inch Class 300 RF ANSI Flange or 2-1/2 inch NPT
<b>Discharge Ports</b>	1-1/2 inch Class 2500 RTJ ANSI Flange or 1-1/2 inch NPT
<b>Shaft Diameter</b>	3 inch (76.2 mm)
<b>Shaft Rotation</b>	Uni-directional (see rotation arrows)
<b>Oil Capacity</b>	18 US quarts (17 liters) - blank back cover 20.5 US quarts (19.4 liters) - oil monitor cover
<b>Weight (dry)</b>	Metallic Heads: 1100 lbs (499 kg)

### Note:

S/N 436513 and lower - standard diaphragms.

S/N 436514 and higher - upgraded diaphragms.

# T100 Series Medium - Specifications (Cont'd)

## Performance

T100 Medium Pressure

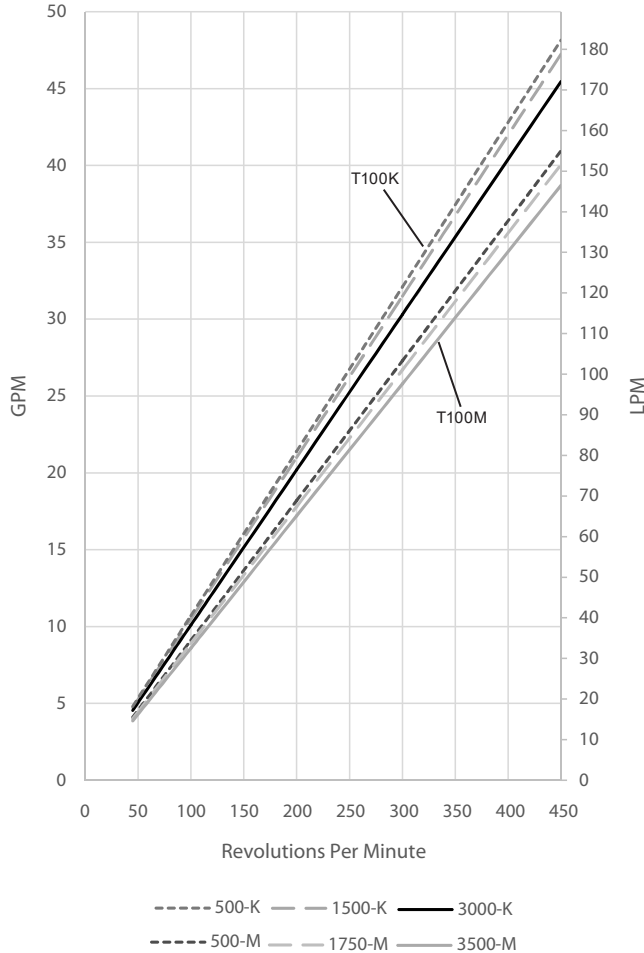

## Net Positive Suction Head – NPSHr

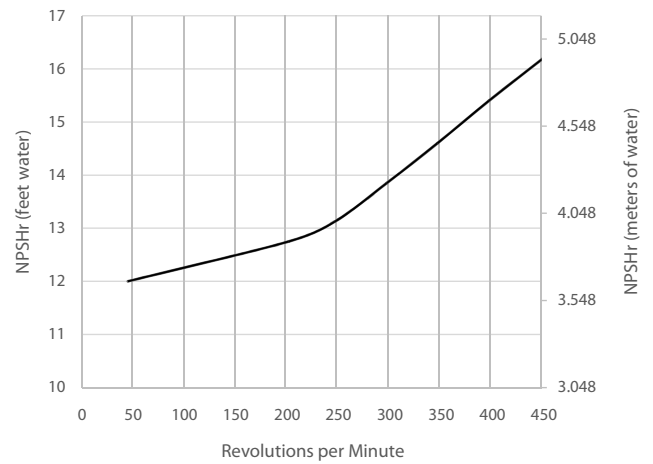

## Calculating Required Horsepower (kW)\*

$$\frac{\text{gpm} \times \text{psi}}{1,460} = \text{electric motor HP}^*$$

$$\frac{\text{l/min} \times \text{bar}}{511} = \text{electric motor kW}^*$$

\* HP/kW is required application power.

### Attention!

When sizing motors with variable speed drives (VFDs), it is very important to select a motor and a VFD rated for constant torque inverter duty service and that the motor is rated to meet the torque requirements of the pump throughout desired speed range.

# T100 Series Medium Pressure - Dimensions

## Flange Version

inches  
(mm)

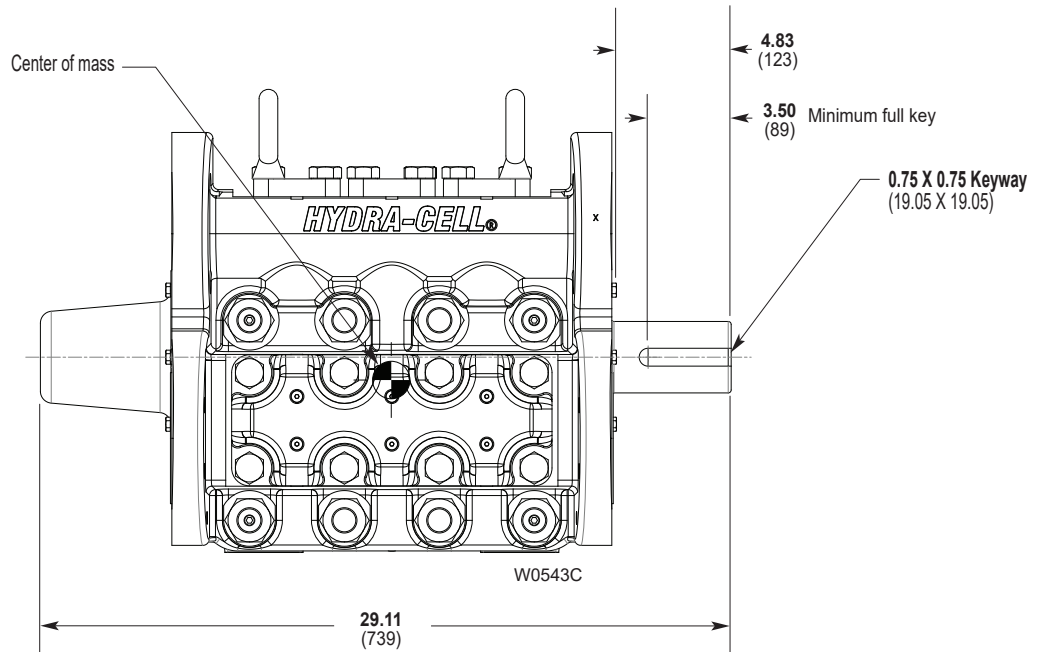

## Front View

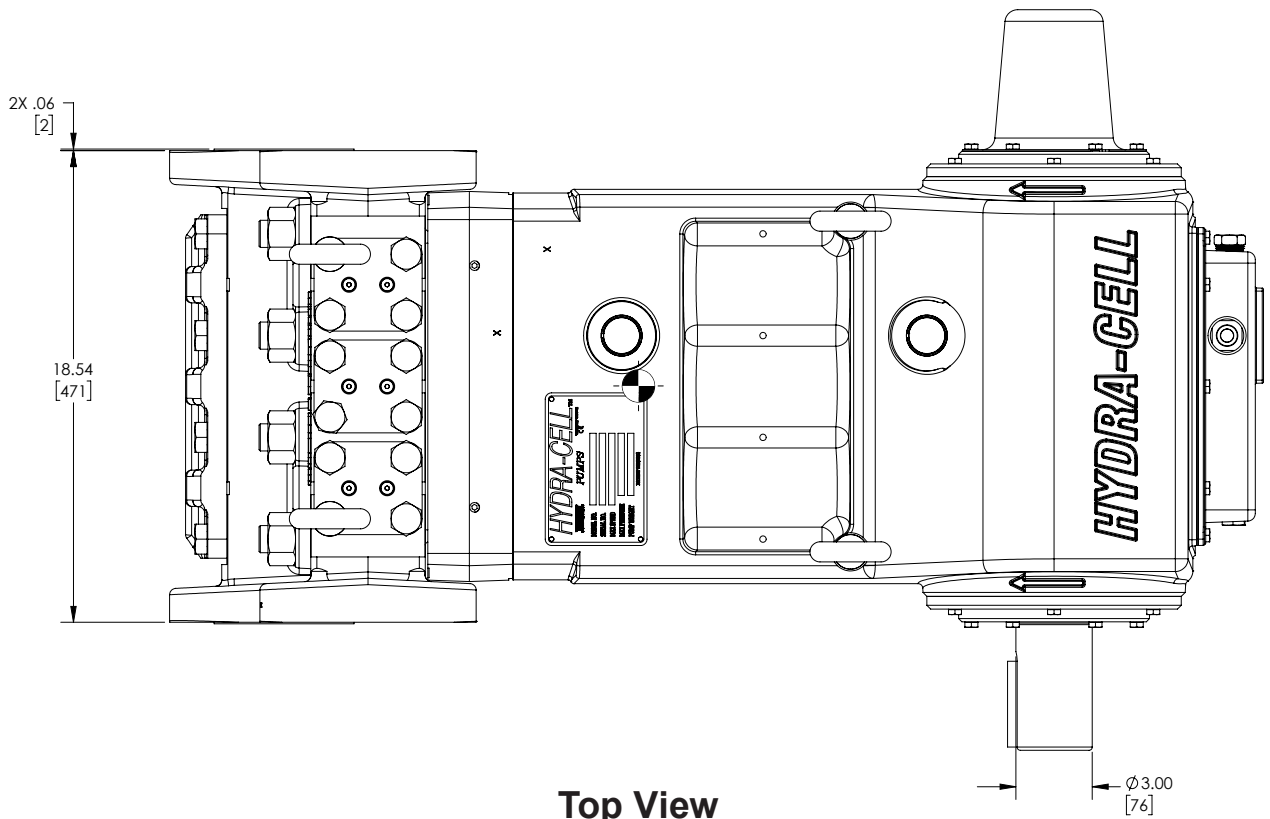

## Top View

# T100 Series Medium - Dimensions (Cont'd)

## Flange Version

inches  
(mm)

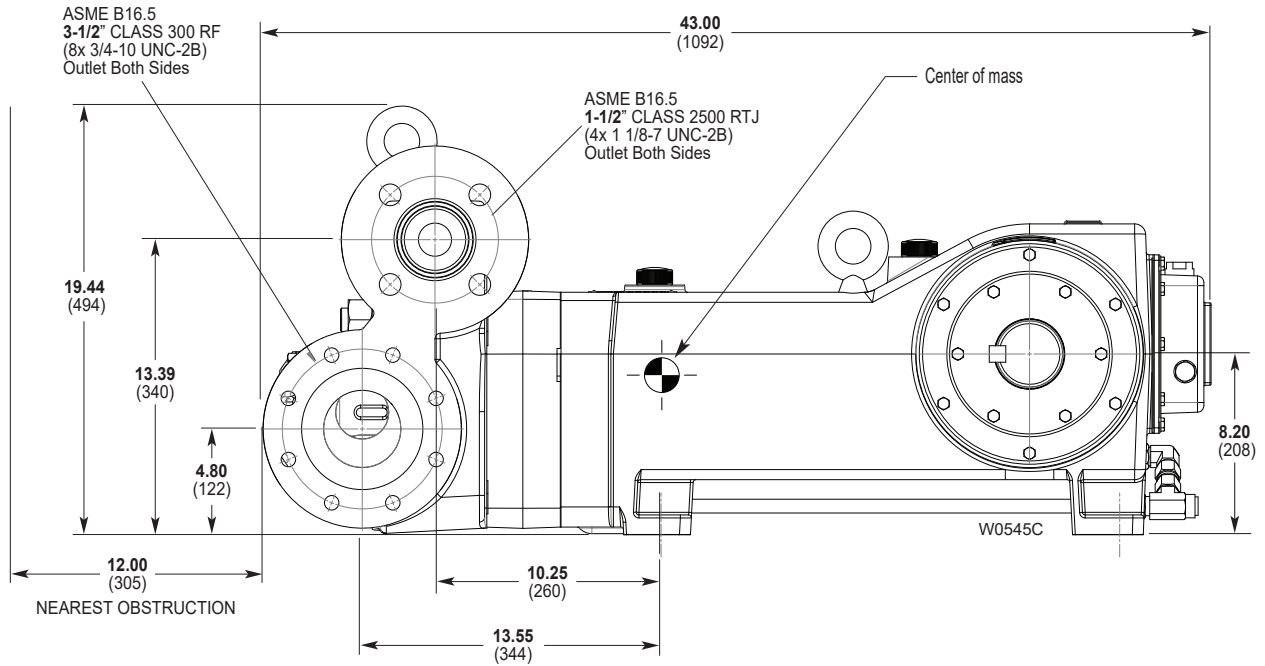

Side View

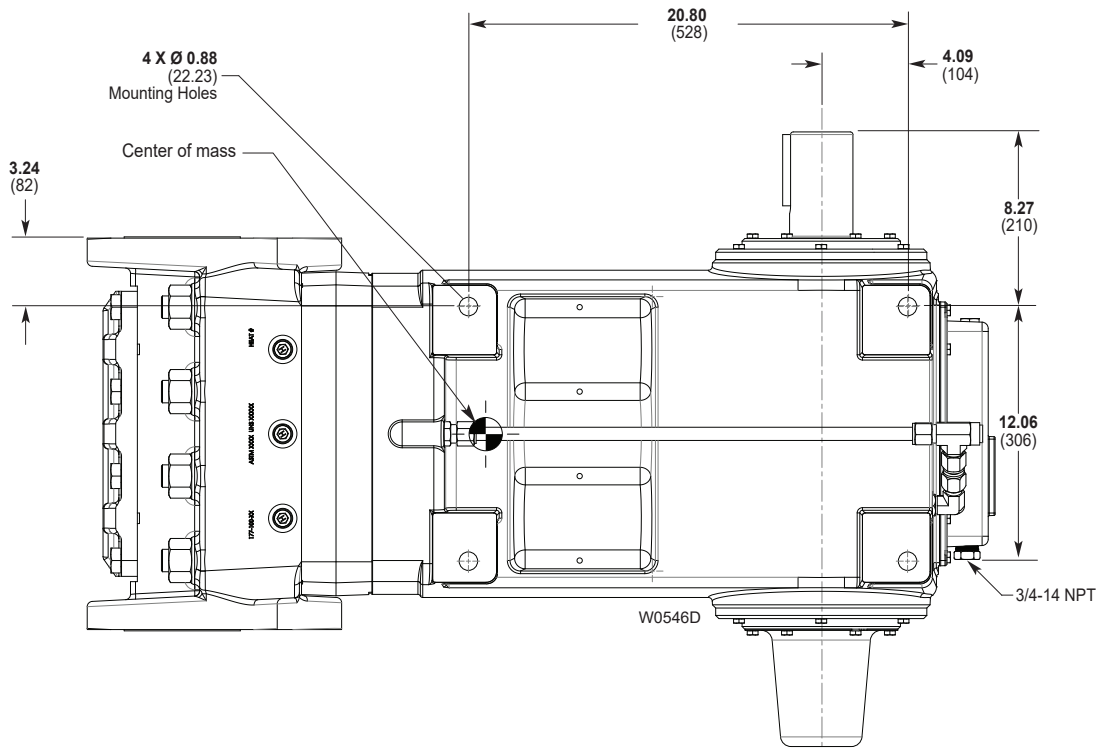

Bottom View

# T100 Series Medium Pressure - Dimensions

## NPT Version

inches  
(mm)

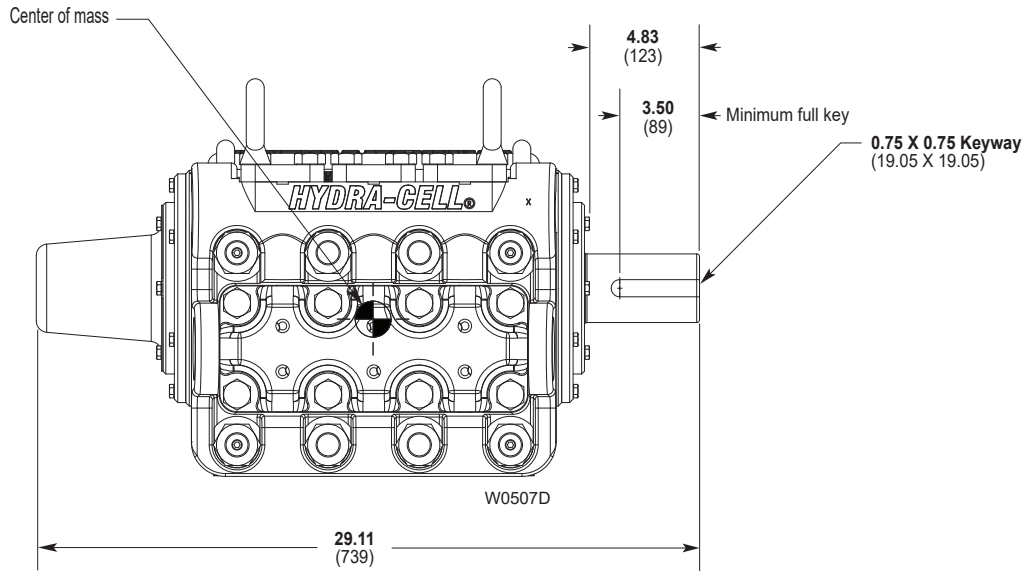

## Front View

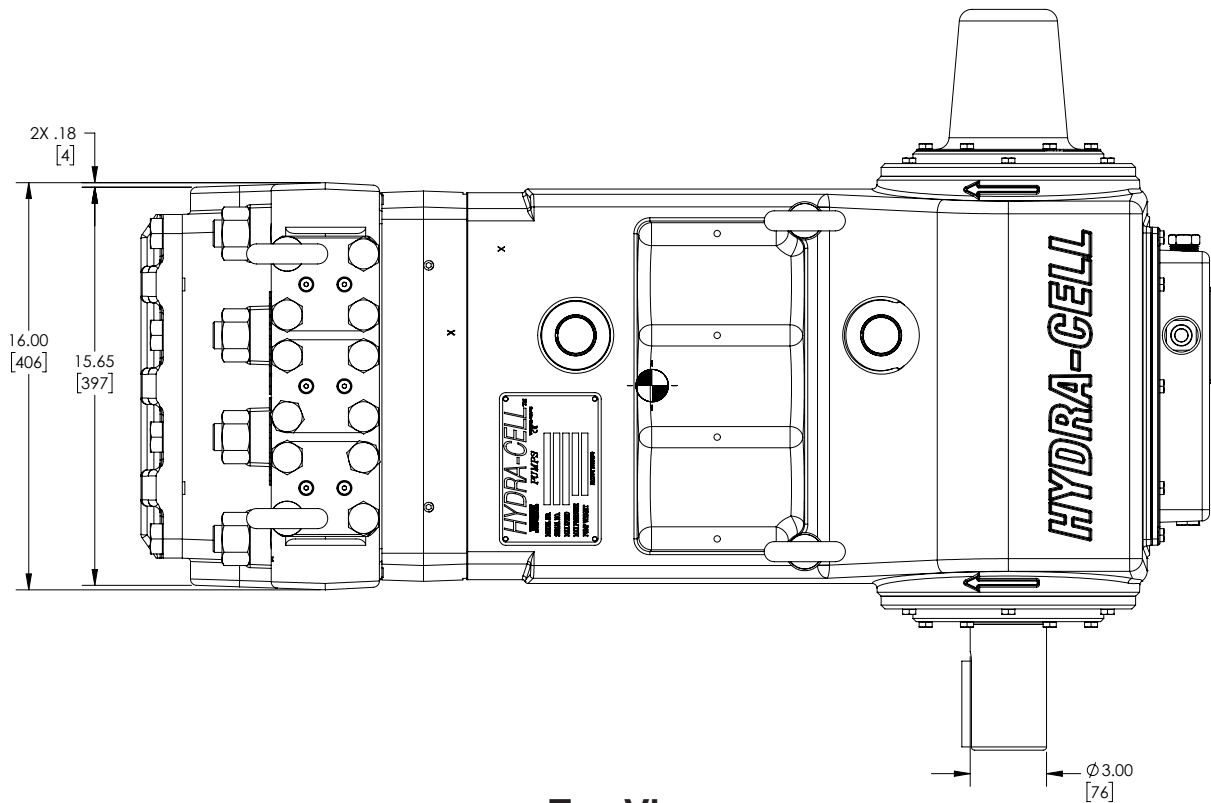

## Top View

# T100 Series Medium - Dimensions (Cont'd)

## NPT Version

inches  
(mm)

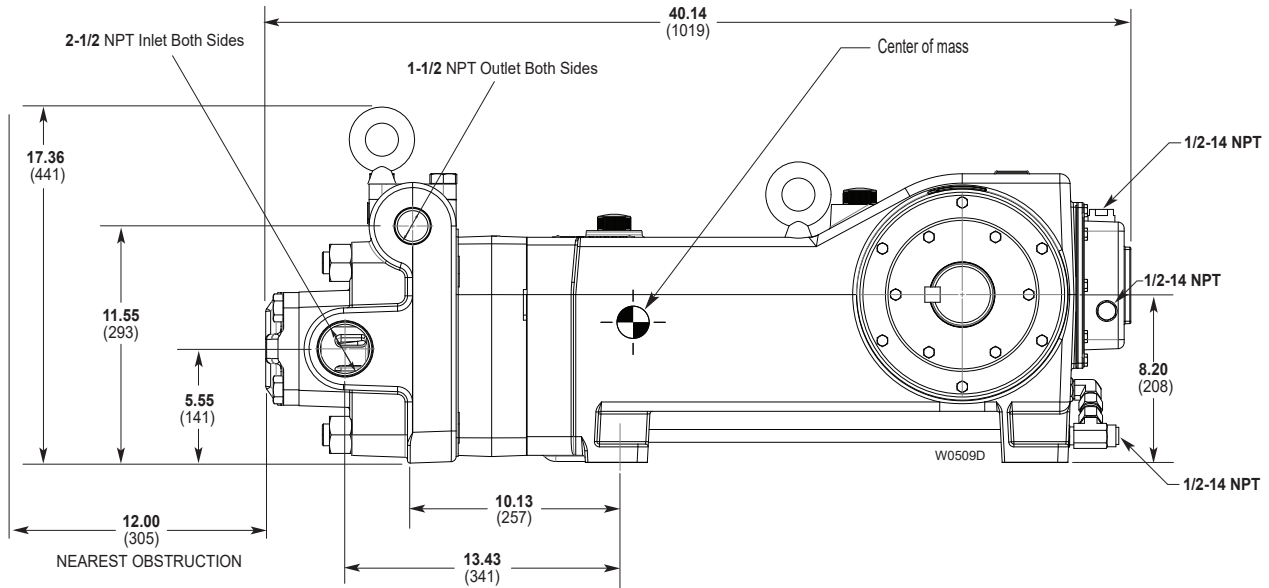

## Side View

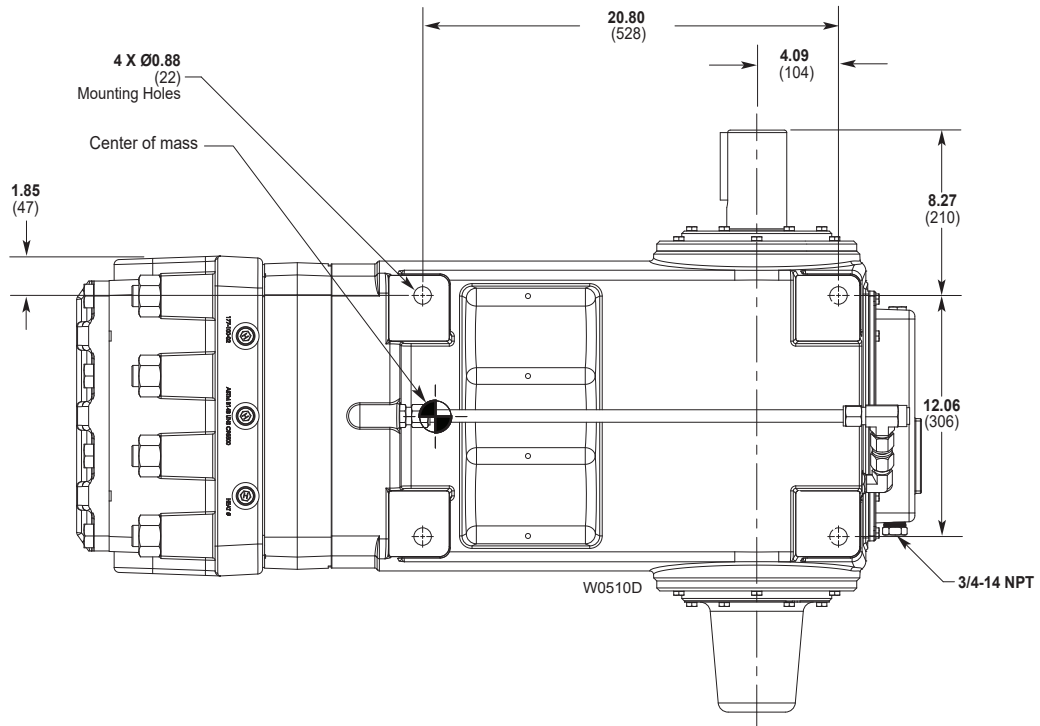

## Bottom View

# T100 Series Medium Pressure - Installation

## Location

Locate the pump as close to the fluid supply source as possible.

Install it in a lighted clean space where it will be easy to inspect and maintain. Allow room for checking the oil level, changing the oil (drain plug on the bottom of pump), and removing the pump head components (inlet and discharge retaining plates, manifold, and related items).

## Rigging Provisions and Procedures

Lift pump by attaching rigging to all four eyebolts (14). Adjust attachment lengths to keep pump level during lifting. **CAUTION: Eyebolts (14) are rated to lift the weight of the pump only. Also see center of mass references in the Dimension Drawings Section.**

## Mounting

**CAUTION: The pump shaft rotation direction is indicated by arrows on the pump housing.**

To prevent vibration, mount the pump and motor securely on a level rigid base.

On a belt-drive system, align the sheaves accurately; poor alignment wastes horsepower and shortens the belt and bearing life. Make sure the belts are properly tightened, as specified by the belt manufacturer.

On a direct-drive system, align the shafts accurately. Unless otherwise specified by the coupling manufacturer, maximum parallel misalignment should not exceed 0.015 in. (0.4 mm) and angular misalignment should be held to 1° maximum. Careful alignment extends life of the coupling, pump, shafts, and support bearings. Consult coupling manufacturer for exact alignment tolerances.

## Important Precautions

**Adequate Fluid Supply.** To avoid cavitation and premature pump failure, be sure that the pump will have an adequate fluid supply and that the inlet line will not be obstructed. See "Inlet Piping" and consult NPSH chart.

**Positive Displacement.** This is a positive-displacement pump. Install a relief valve downstream from the pump. See "Discharge Piping".

**Safety Guards.** Install adequate safety guards over all pulleys, belts, and couplings. Follow all local codes and regulations regarding installation and operation of the pumping system.

**Shut-Off Valves.** Never install shut-off valves between the pump and discharge pressure regulator, relief valve, or in the regulator bypass line.

**Freezing Conditions.** Protect the pump from freezing. See also the Maintenance Section.

**Vacuum at Outlet.** Do not allow a vacuum at the pump outlet during shutdown. A vacuum can damage the diaphragm at start-up. If there is a vacuum at the pump outlet, allow atmospheric pressure at the outlet for 30 minutes before starting. Wanner Engineering recommends installing an outlet check valve with a 65 psi (4.5 bar) cracking pressure to prevent a vacuum condition during shutdown.

### Consult the Factory for the following situations:

- Fluid temperature applications – above 180° F (82° C) or below 40° F (4.4° C)
- Pressure feeding of pumps over 500 psig (34.5 bar)
- Viscous fluid applications above 100 Cps
- Chemical compatibility problems
- Hot ambient temperatures – above 110° F (43° C)
- Conditions where pump oil may exceed 200° F (93° C) because of a combination of hot ambient temperatures, hot fluid temperature, and full horsepower load — an oil cooler may be required
- Pump rpm less than 45

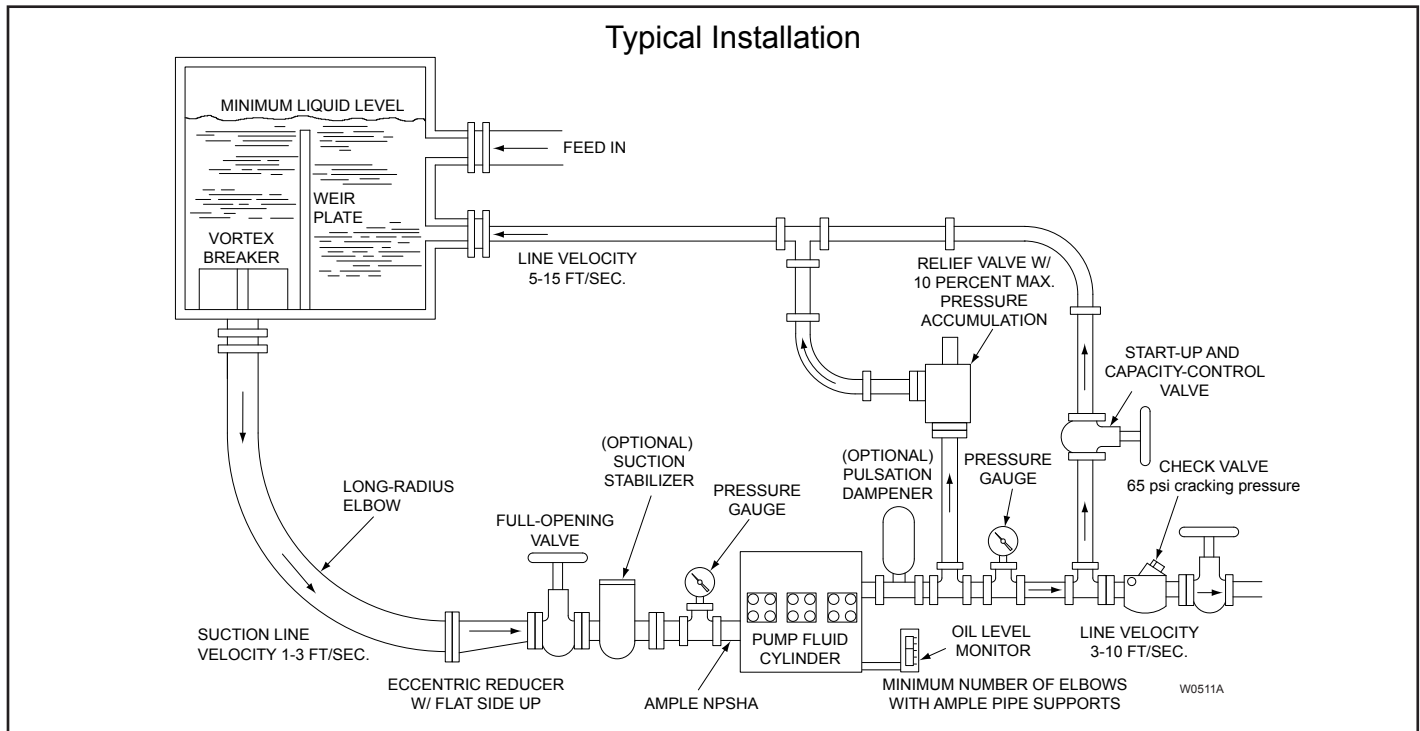



# T100 Series Medium - Installation (Cont'd)

## Accessories

Consult installation drawing below for typical system components. Contact Wanner Engineering or the distributor in your area for more details.

## Inlet Piping (Suction Feed)

Install drain cocks at any low points of the suction line, to permit draining in freezing conditions.

Provide for permanent or temporary installation of a vacuum gauge to monitor the inlet suction. To maintain maximum flow, NPSHA must exceed NPSHR (See chart in Specifications Section). **Do not supply more than one pump from the same inlet line if possible.**

Install a low suction pressure shutdown switch.

## Supply Tank

Use a supply tank that is large enough to provide time for any trapped air in the fluid to escape. The tank size should be at least five times the maximum pump flow rate (in gpm or lpm). *For example: at a maximum rate of 96 gpm, since trapped air takes five minutes to escape from water,  $5 \times 96 = 480$  gallons for a recommended supply tank size.*

Isolate the pump and motor stand from the supply tank, and support them separately.

Install a separate inlet line from the supply tank to each pump.

Install the inlet and bypass lines so they empty into the supply tank below the lowest water level, on the opposite side of the baffle from the pump suction line.

If a line strainer is used in the system install it in the inlet line to the supply tank.

To reduce aeration and turbulence, install a completely submerged baffle plate to separate the incoming and outgoing liquids.

Install a vortex breaker in the supply tank, over the outlet port to the pump.

Place a cover over the supply tank, to prevent foreign objects from falling into it.

## Hose and Routing

Size the suction line at least one size larger than the pump inlet, and so that the velocity will be 1-3 ft/sec (0.3 to 0.9 m/s):

For pipe in inches: Velocity (ft/sec) =  $0.408 \times \text{GPM}/\text{Pipe ID}^2$   
For pipe in mm: Velocity (m/sec) =  $21.2 \times \text{LPM}/\text{Pipe ID}^2$

Keep the suction line as short and direct as possible.

Use flexible hose and/or expansion joints to absorb vibration, expansion, or contraction.

If possible, keep suction line level. Do not have any high points collecting vapor unless high points are vented.

To reduce turbulence and resistance, do not use 90° elbows. If turns are necessary in the suction line, use 45° elbows or arrange sweeping curves in the flexible inlet hose.

If a block valve is used, be sure it is fully opened so that the flow to the pump is not restricted. The opening should be at least the same diameter as the inlet plumbing ID.

Do not use a line strainer or filter in the suction line unless regular maintenance is assured. If used, choose a top loading basket. It should have a free-flow area of at least three times the free-flow area of the inlet.

Install piping supports where necessary to relieve strain on the inlet line and to minimize vibration.

## Inlet Piping (Pressure Feed)

Provide for permanent or temporary installation of a vacuum/pressure gauge to monitor the inlet vacuum or pressure. Pressure at the pump inlet should not exceed 500 psi (34.5 bar); if it could get higher, install an inlet pressure reducing regulator. Do not supply more than one pump from the same inlet line.

## Inlet Calculations

### Acceleration Head

#### Calculating the Acceleration Head

Use the following formula to calculate acceleration head losses. Subtract this figure from the NPSHa, and compare the result to the NPSHR of the Hydra-Cell pump.

$$H_a = (L \times V \times N \times C) \div (K \times G)$$

where:

$H_a$  = Acceleration head (ft of liquid)

$L$  = Actual length of suction line (ft) — not equivalent length

$V$  = Velocity of liquid in suction line (ft/sec) [ $V = \text{GPM} \times (0.408 \div \text{pipe ID}^2)$ ]

$N$  = rpm of crankshaft

$C$  = Constant determined by type of pump — use 0.066 for the T100K,M Hydra-Cell pumps

$K$  = Constant to compensate for compressibility of the fluid — use: 1.4 for de-aerated or hot water; 1.5 for most liquids; 2.5 for hydrocarbons with high compressibility

$G$  = Gravitational constant (32.2 ft/sec<sup>2</sup>)

### Friction Losses

#### Calculating Friction Losses in Suction Piping

When following the above recommendations (under "Inlet Piping") for minimum hose/pipe I. D. and maximum length, frictional losses in the suction piping are negligible (i.e.,  $H_f = 0$ ) if you are pumping a water-like fluid.

When pumping more-viscous fluids such as lubricating oils, sealants, adhesives, syrups, varnishes, etc.; frictional losses in the suction piping may become significant. As  $H_f$  increases, the available NPSH (NPSHa) will decrease, and cavitation will occur.

In general, frictional losses increase with increasing viscosity, increasing suction-line length, increasing pump flow rate, and decreasing suction-line diameter. Changes in suction-line diameter have the greatest impact on frictional losses: a 25% increase in suction-line diameter cuts losses by more than two times, and a 50% increase cuts losses by a factor of five times.

Consult the factory before pumping viscous fluids.

# T100 Series Medium - Installation (Cont'd)

## Minimizing Acceleration Head and Frictional Losses

To minimize the acceleration head and frictional losses:

- Keep inlet lines less than 6 ft (1.8 m) or as short as possible
- Use at least 4 in. (102 mm) I.D. inlet hose
- Use **suction** hose (low-pressure hose, non collapsing) for the inlet lines
- Minimize fittings (elbows, valves, tees, etc.)
- **Use a suction stabilizer on the inlet.**

## Net Positive Suction Head

NPSHa must be equal to or greater than NPSHr. If not, the pressure in the pump inlet will be lower than the vapor pressure of the fluid — and cavitation will occur.

### Calculating the NPSHa

Use the following formula to calculate the NPSHa:

$$NPSHa = P_t + H_z - H_f - H_a - P_{vp}$$

where:

$P_t$  = Atmospheric pressure

$H_z$  = Vertical distance from liquid surface to pump center line  
(if liquid is below pump center line, the  $H_z$  is negative)

$H_f$  = Friction losses in suction piping

$H_a$  = Acceleration head at pump suction

$P_{vp}$  = Absolute vapor pressure of liquid at pumping temperature

Notes:

- In good practice, NPSHa should be 2 ft greater than NPSHr
- All values must be expressed in feet of liquid

### Atmospheric Pressure at Various Altitudes

Altitude (ft)	Pressure (ft of H <sub>2</sub> O)	Altitude (ft)	Pressure (ft of H <sub>2</sub> O)
0	33.9	1500	32.1
500	33.3	2000	31.5
1000	32.8	5000	28.2

## Discharge Piping

### Hose and Routing

Use the shortest, most-direct route for the discharge line.

Select pipe or hose with a **working pressure** rating of at least 1.5 times the maximum system pressure. EXAMPLE: Select a 1500 psi W.P.-rated hose for systems to be operated at 1000 psi-gauge pressure.

Use flexible hose between the pump and rigid piping to absorb vibration, expansion or contraction.

Do not use 90 degree elbows within 10 pipe diameters of the pump discharge port.

Support the pump and piping independently. Size the discharge line so that the velocity of the fluid will be 3-10 ft/sec (1-3 m/sec):

For pipe in inches: Velocity (ft/sec) = 0.408 x GPM/Pipe ID<sup>2</sup>

For pipe in mm: Velocity (m/sec) = 21.2 x LPM/Pipe ID<sup>2</sup>

## Pressure Relief

**Install a pressure relief valve in the discharge line.** Bypass pressure must not exceed the pressure limit of the pump.

Size the relief valve so that, when fully open, it will be large enough to relieve the full capacity of the pump without overpressurizing the pump.

Locate the valve as close to the pump as possible and ahead of any other valves.

Adjust the pressure relief valve to no more than 10% over the maximum working pressure of the pump.

Route the bypass line to the supply tank, never to the suction line of the pump. See the diagram showing a typical installation at the beginning of the Installation Section.

If the pump may be run for a long time with the discharge closed and fluid bypassing, install a thermal protector in the bypass line (to prevent severe temperature buildup in the bypassed fluid).

**CAUTION: Never install shutoff valves in the bypass line or between the pump and pressure relief valve.**

Install a pressure gauge in the discharge line.

**Vacuum at Outlet.** Do not allow a vacuum at the pump outlet during shutdown. A vacuum can damage the diaphragm at start-up. If there is a vacuum at the pump outlet, allow atmospheric pressure at the outlet for 30 minutes before starting. Wanner Engineering recommends installing an outlet check valve with a 65 psi cracking pressure to prevent a vacuum condition during shutdown.

**Oil Level Monitoring.** Oil level is sensed by the back cover float switch (48) and can be used to control the pump system operation.

## Before Initial Start-Up

Before you start the pump, be sure that:

- Pump is stored at a temperature above the minimum service temperature for a minimum of 24 hours before start up.
  - All shutoff valves are open, and the pump has an adequate supply of fluid.
  - All connections are tight.
  - The oil level is correct. Add oil as needed. The oil level can also be viewed through the sight glass (42) on the back cover (12). The oil level is OK when the float (48) is in the middle of the sight glass.
  - Connect the float switch (if used). See Float Switch Section.
  - Test the float switch by removing the side port plug (50) and manipulating the float up and down using a suitable tool (screwdriver). Reinstall side port plug.
- CAUTION: Take care not to drop tool inside pump.**
- The relief valve on the pump outlet is adjusted so the pump starts under minimum pressure.
  - All shaft couplings or drive pulleys have adequate safety guards.

# T100 Series Medium - Installation (Cont'd)

---

## Initial Start-Up

1. Pump must be at or above minimum temperature specified in diaphragm temperature limits table for 24 hours prior to starting.
2. Open the bypass line start-up and capacity-control valve so the pump may be started against negligible discharge pressure.
3. Turn on power to the pump motor.
4. Check the inlet pressure or vacuum. To maintain maximum flow, inlet vacuum must not exceed 7 in. Hg at 70° F (180 mm Hg at 21° C). Inlet pressure must not exceed 500 psi (34 bar).
5. Listen for any erratic noise, and look for unsteady flow. If the pump does not clear, refer to the Troubleshooting Section.
6. If the system has an air lock and the pump fails to prime:
  - a. Turn off the power.
  - b. Remove the pressure gauge from the tee fitting at the pump outlet (see installation diagram).

**Note: Fluid may come out of this port when the plug is removed. Provide an adequate catch basin for fluid spillage, if required. Fluid will come out of this port when the pump is started, so we recommend that you attach adequate plumbing from this port so fluid will not be sprayed or lost. Use high-pressure-rated hose and fittings from this port. Take all safety precautions to assure safe handling of the fluid being pumped.**

- c. Jog the system on and off until the fluid coming from this port is air-free.
  - d. Turn off the power.
  - e. Remove the plumbing that was temporarily installed, and reinstall the pressure gauge or plug.
7. Adjust the bypass line valve to the desired operating pressure. Do not exceed the maximum pressure rating of the pump.
  8. After the system pressure is adjusted, verify the safety relief valve setting by closing the bypass line valve until the relief valve opens.

**Note: Fluid may come out of the safety relief valve. Provide an adequate catch basin for fluid spillage. Take all safety precautions to assure safe handling of the spillage.**

9. Reset the bypass line valve to obtain the desired system pressure.
10. Provide a return line from the relief valve to the supply tank, similar to the bypass line.

# T100 Series Medium - Maintenance

---

## Maintenance

**Note:** The numbers in parentheses are the Reference Numbers shown in the Parts Section of the manual.

### Daily

Check the oil level and the condition of the oil with the pump turned off. The oil level should be within the acceptable range with the float in the middle of the sight glass. Add oil as needed or use continuous monitor.

Use the appropriate Hydra-Oil for the application (contact Wanner Engineering if in doubt).

**CAUTION:** If you are losing oil but don't see any external leakage, or if the oil becomes discolored and contaminated, one of the diaphragms (78) may be damaged. Refer to the Fluid-End Service Section. Do not operate the pump with a damaged diaphragm.

**Do not leave contaminated oil in the pump housing or leave the housing empty. Remove contaminated oil as soon as discovered, and replace it with clean oil.**

### Periodically

***Change the oil after the first 500 hours of operation; and then every 2000 hours or six months, whichever comes first.***

**Note:** Hydra-Cell T100 Series Pumps come standard with 10W30 motor oil.

**Note:** Minimum oil viscosity for proper hydraulic end lubrication is 80 cST (371 SSU) at 104°F (40°C).

**Use of an oil cooler is recommended when process fluid and/or hydraulic end oil exceeds 180°F (82.2°C).**

When changing oil, remove drain plug (40) at the bottom of the pump so all oil and accumulated sediment will drain out.

Check the inlet pressure or vacuum periodically with a gauge. If vacuum at the pump inlet exceeds NPSHR, check the inlet piping system for blockages. If the pump inlet is located above the supply tank, check the fluid supply level and replenish if too low.

Inspect pump for hydraulic oil or process fluid leaks.

## Shutdown Procedure During Freezing Temperatures

**Take all safety precautions to assure safe handling of the fluid being pumped. Provide adequate catch basins for fluid drainage and use appropriate plumbing from drain ports, etc., when flushing the pump and system with a compatible antifreeze. Drain ports are located in the manifold.**

## Recommended Tools and Supplies

The following tools and supplies are recommended for servicing the T100K,M Pump:

10 mm hex socket with extension

30 mm hex socket

46 mm hex socket

3/4 in. hex socket

8 mm box-end wrench

13 mm open-end wrench

9/16 in. box-end wrench

3 mm hex wrench

4 mm hex wrench

8 mm hex wrench

3/8 in. hex wrench

Torx T30

Torx T45

Flathead screwdriver

No. 3 Phillips-head screwdriver

Internal retaining ring pliers

8 in. adjustable wrench

Torque wrench, adjustable from 250 to 450 ft-lbs (339 to 610 N-m)

Pipe wrench

Loctite 242

New Hydra-Oil

Wanner T100 Medium Pressure Tool Kit (see T100 Medium Pressure Tool Kit Parts)

# T100 Series Medium - Fluid End Service

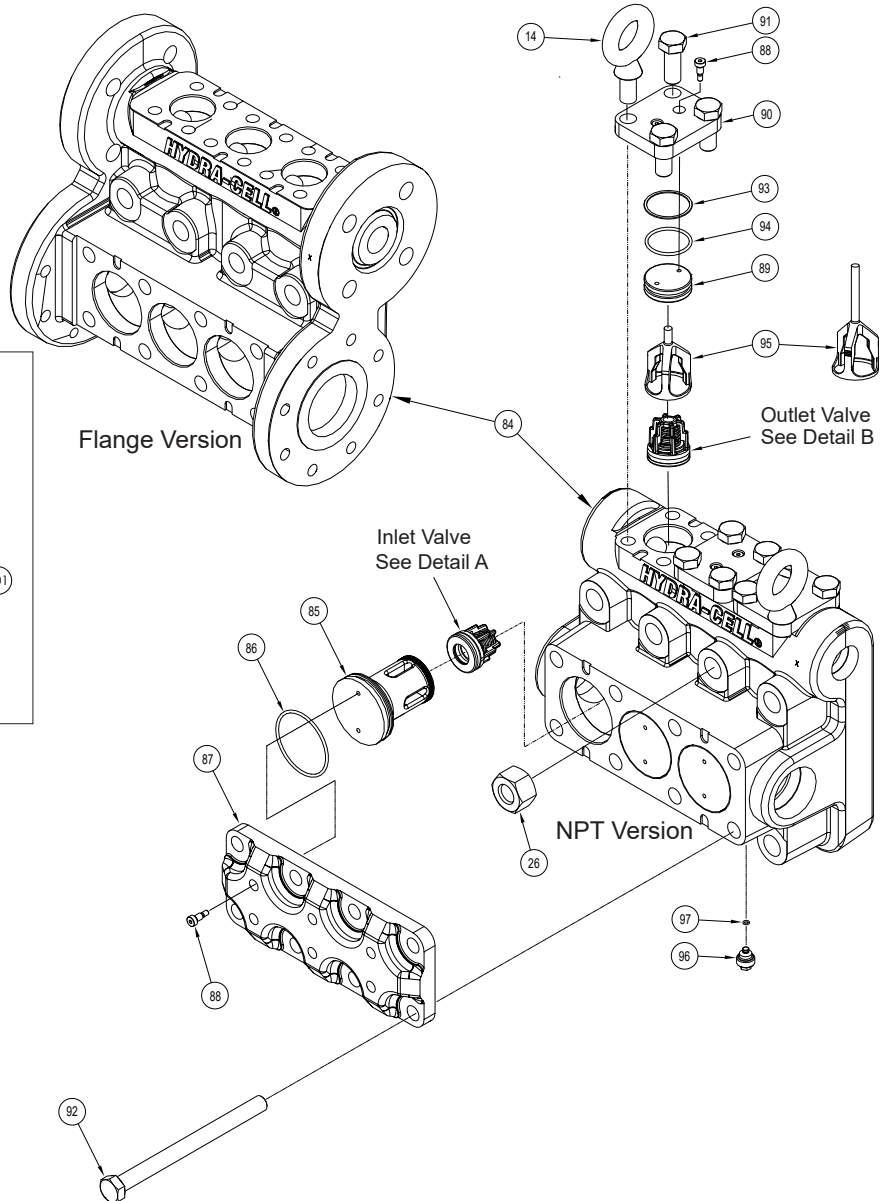
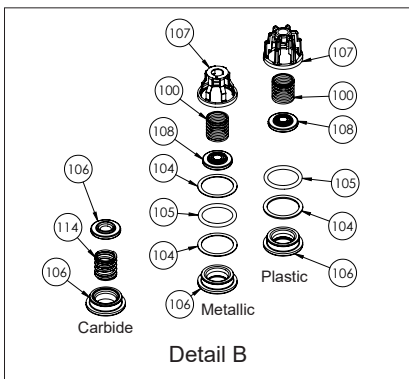
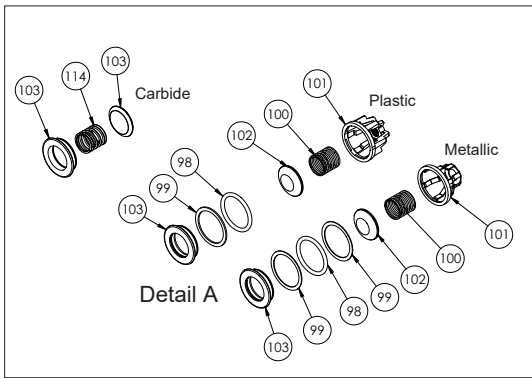
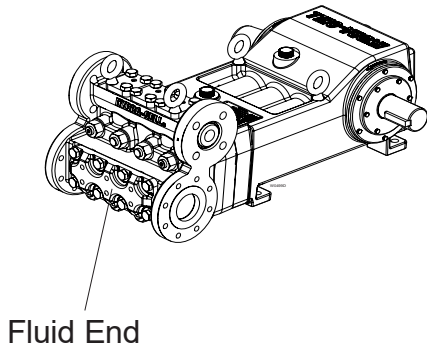

Note: for torque values refer to the Torque Specifications Table.

# T100 Series Medium - Fluid End Service (Cont'd)

This section explains how to disassemble and inspect all easily-serviceable parts of the pump.

**CAUTION - For servicing of pumps certified for use in explosive atmospheres (ATEX/IECEX) please see separate supplementary manual.**

**Note: The numbers in parentheses are the Reference Numbers shown in the Parts Section of the manual.**

## Fluid End Service

### Inlet Check Valve Disassembly

- See *Fluid End Parts View*. Remove eight bolts (92) around inlet retainer plate (87).
- Remove inlet retainer plate and three inlet retainer plugs (85) with assembled O-rings (86).
- Check O-rings and inlet retainer plugs for wear. Replace if worn. Lubricate new O-rings with petroleum jelly or lubricating gel. Each inlet retainer plug is attached to inlet retainer plate with two screws (88).
- Inspect inlet retainer plate for warping or wear around inlet ports. Look for corrosion, scale and wear. If wear is excessive, replace inlet retainer plate. Clean inlet retainer plate of any scale and corrosion with Scotch-Brite™ pad or fine emery cloth. Wash after cleaning. To check if inlet retainer plate is warped, place a straightedge across it. A warped inlet retainer plate should be replaced.
- Remove three inlet check valve cartridges (98-103) with check valve extraction tool. Tool is included in Wanner Tool Kit.

**CAUTION - For Inlet Carbide Valve Assemblies (when used).**

**Inlet Carbide Valve Assemblies are a matched set (consisting of items 102 and 103) and must be installed together. Failure to install Inlet Carbide Valve Assemblies as a matched set will cause pump damage.**

- Inspect each of three check valve cartridges for wear and leakage at seat. Replace inlet check valve cartridges as needed.
- Using a light, visually inspect diaphragms through inlet ports. If diaphragms appear abnormal or damaged, remove and replace as instructed in Diaphragm Parts Disassembly.

### Outlet Check Valve Disassembly

**Note: Removal of Inlet Check Valves first will make removal of Outlet Check Valves easier.**

- Remove two eyebolts (14) and ten cap screws (91) around discharge retainer plates (90).
- Remove discharge retainer plate with assembled outlet valve port plugs (89), backup rings (93), O-rings (94), and outlet valve retainers (95).
- Check outlet valve port plugs, backup rings, O-rings, and outlet valve retainers for wear. Replace if worn. Lubricate new O-rings with petroleum jelly or lubricating gel. Outlet valve port plugs are attached to discharge retainer plates with two screws (88).

- Inspect discharge retainer plates for warping or wear around discharge ports. Look for corrosion, scale and wear. If wear is excessive, replace discharge retainer plate. Clean discharge retainer plates of any scale and corrosion with Scotch-Brite™ pad or fine emery cloth. Wash after cleaning. To check if discharge retainer plate is warped, place a straightedge across it. A warped discharge retainer plate should be replaced.
- Remove three outlet check valve cartridges (100, 104-108) with check valve extraction tool. Tool is included in Wanner Tool Kit.

**CAUTION - For Inlet Carbide Valve Assemblies (when used).**

**Inlet Carbide Valve Assemblies are a matched set (consisting of items 108 and 106) and must be installed together. Failure to install Inlet Carbide Valve Assemblies as a matched set will cause pump damage.**

- Inspect each of three check valve cartridges for wear and leakage at seat. Replace outlet check valve cartridges as needed.

### Outlet Check Valve Assembly

- Reinstall three outlet check valve cartridges (100, 104-108).
- Reinstall discharge retainer plates (90) with assembled outlet valve port plugs (89) with two screws (88) [Torque to 75 in-lbs (8 N-m)], backup rings (93), O-rings (94), and outlet valve retainers (95); using ten cap screws (91) and two eyebolts (14). (Check illustration) Hand thread cap screws and eyebolts.
- Tighten cap screws from opposing corners to opposing corners of discharge retainer plates. Torque to 300 ft-lbs (407 N-m).
- Tighten eyebolts with crow bar or hammer.

### Inlet Check Valve Assembly

- Reinstall three inlet check valve cartridges (98-103).
- Reinstall inlet retainer plates (87) and inlet retainer plugs (85) with two screws (88) and assembled O-rings (86). Use eight bolts (92) to fasten inlet retainer plate. Hand thread bolts, then tighten from inner to outer. See *Manifold Assembly Torque Sequence Diagram*. Torque to 300 ft-lbs (407 N-m).

### Drain Plug

- Remove and replace drain plug (96) and O-ring (97) as needed. Torque drain plug with O-ring to 40 ft-lbs (54 N-m). Apply Loctite nickel anti-seize lubricant to thread and chamfer of plug.

**CAUTION - For servicing of pumps certified for use in explosive atmospheres (ATEX/IECEX) please see separate supplementary manual.**

**Note: The numbers in parentheses are the Reference Numbers shown in the Parts Section of the manual.**

# T100 Medium - Hydraulic Section Service

## Hydraulic Section Disassembly

### Manifold Disassembly

**⚠ WARNING: Manifold (84) and assembled parts weigh over 350 pounds (159 kg) and are a two man lift. Use care in handling to prevent personal injury or damage to equipment.**

- See *Power End Parts Illustration in Parts List*. Remove drain plug (40) from bottom of pump and drain oil into container (capable of holding 20.5 qts [19.4 liters] of oil). Dispose of old oil in an approved way.
- Replace drain plug.
- See *Fluid End Parts View*. Remove eight bolts (92) around inlet retainer plate (87).
- Remove eight hex nuts (26) from fluid end of pump. Install four 177-393 Extender Studs from T100 Tool Kit on studs (20). Carefully slide manifold (84) forward along extender studs to allow access to diaphragm plate (52).

### Diaphragm Disassembly

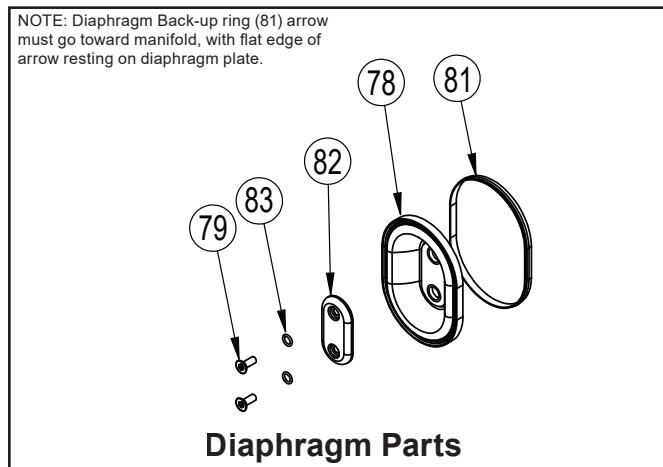

- See *Diaphragm Parts View*. Remove four screws (79), four O-rings (83) and follower (82).

**CAUTION: If a diaphragm has ruptured and foreign material or water has entered the oil reservoir, do not operate the pump. Check all diaphragms, then flush the reservoir completely and refill it with fresh oil. Never let the pump stand with foreign material or water in the reservoir, or with the reservoir empty.**

- Remove the diaphragm (78) and diaphragm back-up ring (81). Inspect diaphragm carefully for any abnormal conditions. A ruptured diaphragm generally indicates a pumping system problem, and replacing only the diaphragm will not solve the larger problem. Inspect the diaphragm for the following:

- Small puncture.** Usually caused by a sharp foreign object in the fluid.
  - Diaphragm pulled away** from the center screw or from the cylinder sides. Usually caused by fluid being frozen in the pump, or by overpressurization of the pump.
  - Diaphragm becoming stiff** and losing flexibility. Usually caused by pumping a fluid that is incompatible with the diaphragm material.
  - Slice in ridge of diaphragm.** Occurs when diaphragm is operated at cold temperatures.
  - Diaphragm torn concentrically in the mid convolute area.** Usually an indication of an outlet vacuum condition.
- Inspect screw plug (110) for signs of wear. Replace if needed.
  - If needed replace diaphragm.
  - Replace diaphragm back-up ring if needed.

### Bias Rod Disassembly

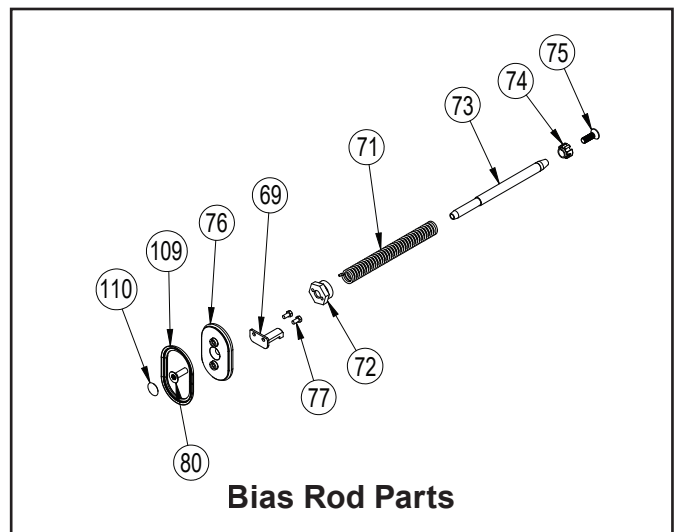

- See *Bias Rod Parts and Diaphragm Parts Views*. Remove diaphragm parts as in steps a. through e. above.
- Remove screw (80) and diaphragm clamp (76) with support ring (109) valve arm (69) and two attaching screws (77).
- Remove valve spool (54) from diaphragm plate (52).
- Check diaphragm clamp for any rough surfaces, edges, or corrosion. Replace if necessary.
- Check support ring (109) for any rough surfaces, edges, corrosion, tears, or loose fitment around diaphragm clamp. Replace if necessary
- Unscrew bias tube cap (72).
- Remove bias rod parts: bias spring (71), bias rod (73), spring guide (74), and screw (75).
- Inspect rod parts. Smooth surfaces and edges as necessary with emery cloth or fine file. Replace parts as necessary.

# T100 Medium - Hydraulic Section Service (Cont'd)

---

## Hydraulic Section Disassembly (Cont'd)

### Diaphragm Plate Disassembly

 **WARNING: Manifold (84) and assembled parts weigh over 350 pounds (159 kg) and are a two man lift. Use care in handling to prevent personal injury or damage to equipment.**

- a. Slide manifold (84) away from diaphragm plate (52), following steps a. through d. in the Remove Manifold Assembly Section.

 **WARNING: Diaphragm plate (52) and assembled parts weigh over 150 pounds (68 kg) and are a two man lift. Use care in handling to prevent personal injury or damage to equipment.**

**Note: To ease handling of diaphragm plate, install two Eyebolts (177-058) from T100 Medium Pressure Tool Kit in place of two Setscrews (55) on top of diaphragm plate.**

- b. See *Hydraulic Section Parts view*. Remove two cap screws (56) from diaphragm plate (52).
- c. Carefully slide diaphragm plate and assembled parts away from pump along pump studs.
- d. Replace diaphragm plate gasket (24) if damaged.

### Check/Replace Airbleed Valve

- a. See *Valve Parts View*. Unthread airbleed valve (61) from diaphragm plate (52). Inspect valve and replace if needed.
- b. Reinstall airbleed valve. Torque to 75 ft-lbs (102 N-m).

### Check/Replace Underfill Valve

- a. See *Valve Parts View*. Unthread underfill valve (65) from bottom of diaphragm plate (52). Inspect valve and replace if needed.
- b. Reinstall underfill valve. Torque to 30 ft-lbs (41 N-m).

### Check/Replace Overfill Valve Assembly

- a. See *Valve Parts View*. Unthread overfill valve (57) from bottom of diaphragm plate (52). Inspect overfill valve and replace if needed.
- b. Reinstall overfill valve. Torque to 105 in-lbs (12 N-m).



# T100 Medium - Hydraulic Section Service (Cont'd)

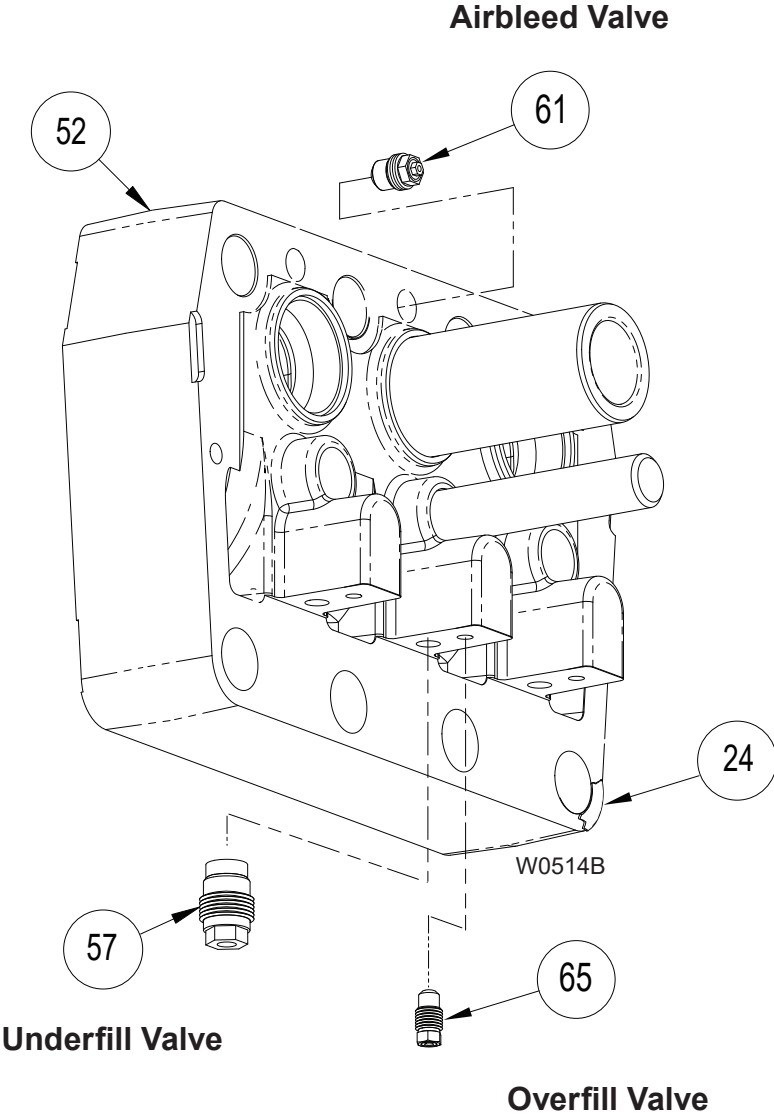

**Valve Parts View**

# T100 Medium - Hydraulic Section Service (Cont'd)

## Hydraulic Section Assembly

### Diaphragm Plate Assembly

 **WARNING:** Diaphragm plate (52) and assembled parts weigh over 100 pounds (45 kg) and are a two man lift. Use care in handling to prevent personal injury or damage to equipment.

**Note:** To ease handling of diaphragm plate, install two Eyebolts (177-058) from T100 Tool Kit in place of two Setscrews (55) on top of diaphragm plate.

- a. Replace diaphragm plate gasket (24) if damaged.

**CAUTION:** Ensure plungers (51) are lubricated with oil before assembly. Dry plungers and cylinders can bind on start-up.

- b. See *Hydraulic Section Parts Illustration*. Carefully slide diaphragm plate (52) and assembled parts along pump studs flush with Power End of pump.
- c. Screw two cap screws (56) into diaphragm plate. Torque to 50 ft-lbs (68 N-m).
- d. Hand rotate to assure smooth operation.

### Bias Rod Assembly

**CAUTION:** It is important to observe the following steps a. and b. to insure proper assembly.

- a. See Bias Rod Parts View. Clean internal threads of bias rod (73) and threads of screw (75). Make sure threads are dry and oil free. Prime threads with Loctite Primer N.
- b. Apply a small amount of No. 271 Loctite to internal threads of bias rod and screw. Insert screw through spring guide (74) and thread into bias rod.
- c. Install bias rod assembly parts into diaphragm plate (52). Thread bias tube cap (72) into bias tube with: bias spring (71), bias rod, spring guide, and screw. Make sure spring tangs mate with spring guide and bias tube cap. Use Loctite 242 on bias tube cap and torque to 50 ft-lbs (68 N-m).
- d. Insert valve spool (54) into diaphragm plate (52).
- e. Insert one round edge of support ring (109) onto round edge of diaphragm clamp (76). Stretch and pull opposite edge of support ring (109) over diaphragm clamp (76). Press in both long flat sides of support ring (109) into diaphragm clamp (76) until flush. Press entire perimeter of support ring (109) until flush with diaphragm clamp (76).
- f. Thread screw (80) through diaphragm clamp (76) with valve arm (69) and two attaching screws (77) into bias rod. Use Loctite 242 on screw (80) and torque to 20 ft-lbs (27 N-m).

**CAUTION:** Use care not to over-tighten as that can cause the rod to rotate and bind the bias spring. Verify the bias spring is not bound by pulling the diaphragm clamp out and verifying that the clamp has full range of motion.

- g. Repeat for three rod assemblies.

### Diaphragm Assembly

- a. See *Diaphragm Parts View*.

**CAUTION:** It is important to observe the following steps d. and e. to ensure proper assembly.

- b. Install screw plug (110) into screw (80). Make sure screw cap is flush with diaphragm clamp (76).
- c. Install the diaphragm (78) into diaphragm plate (52). Seat diaphragm edge with fingers. Make sure diaphragm bead is fully seated into the square groove of diaphragm plate.
- d. Install back-up ring (81) between diaphragm plate and diaphragm.

**Note:** Diaphragm Back-up ring (81) arrow must go toward manifold, with flat edge of arrow resting on diaphragm plate.

- e. Install two O-rings (83) into follower (82).
- f. Attach follower to diaphragm clamp with two screws (79). Use Loctite 242 and torque to 80 in-lbs (9 N-m).
- g. Repeat steps a. through f. for three diaphragms.

# T100 Medium - Hydraulic Section Service (Cont'd)

## Hydraulic Section Assembly (Cont'd)

**WARNING:** Manifold (84) and assembled parts weigh over 350 pounds (159 kg) and are a two man lift. Use care in handling to prevent personal injury or damage to equipment.

### Manifold Assembly

- See *Fluid End Parts View*. Prior to manifold assembly, inspect mating surfaces of pump and manifold. Make sure they are clean and free of any foreign material. Ensure diaphragm beads are seated.
- Carefully slide manifold (84) onto pump studs. If used, remove four 177-393 Extender Studs from pump and install eight bolts (92) around inlet retainer plate (87) and hand tighten.

**CAUTION:** The manifold should slide cleanly onto the pump and the back-up rings should be engaged into the mating grooves in the manifold prior to tightening. Failure to slide the manifold all the way on engaging the back-up rings prior to tightening can cause the back-up ring to be pinched and cause the pump to leak. If the manifold does not slide easily onto the pump, use Scotch-Brite™ or fine abrasive paper to clean the outer edge of the groove where the back-up ring fits.

- Thread on eight hex nuts (26) and hand tighten.
- Tighten hex nuts in torque sequence shown in illustration to 450 ft-lbs (610 N-m).
- Thread on eight bolts (92) and hand tighten.
- Tighten bolts in torque sequence shown in illustration to 300 ft-lbs (407 N-m).
- Fill pump with oil to cover marks on dipstick. Approximately 18 qts (17 liters) with flat back cover or 20.5 US quarts (19.4 liters) with oil monitor back cover.
- Follow instructions in Before Initial Start-Up and Initial Start-Up Section to start pump.

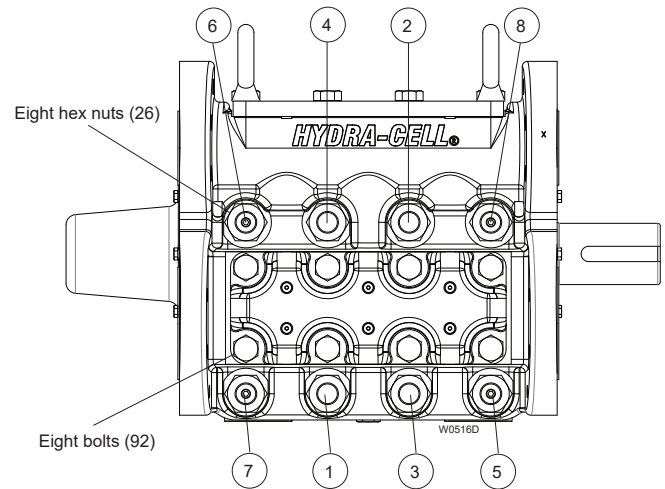

Torque sequence:

Snug eight hex nuts (26) in order indicated to 450 ft-lbs (610 N-m).

Repeat same snug and torque sequence for corresponding bolts (92) to 300 ft lbs (407 N•m).

# T100 Series Medium - Power End Service

## Power End Disassembly

 **WARNING:** Crankcase (2) and assembled parts weigh over 600 pounds (272 kg) and are a two man lift. Use care in handling to prevent personal injury or damage to equipment.

**CAUTION** - For servicing of pumps certified for use in explosive atmospheres (ATEX/IECEx) please see separate supplementary manual.

## Float Switch Back Cover Disassembly

**Note:** The numbers in parentheses are the Reference Numbers shown in the Parts Section of the manual.

- Disconnect float switch (48).
- Remove float switch adapter (47) with float switch and O-ring (46) from back cover (12).
- Remove float switch from float switch adapter.
- Remove twelve screws (16) from crankcase (2).
- Remove back cover and baffle (13).
- Remove eight screws (45) from assembled frame (44) and back cover.
- Disassemble frame, gasket (43), sight glass (42), and thick gasket (41).

## Crankcase Disassembly

- Remove Fluid End and Hydraulic plate as outlined in two preceding sections.
- See *Power End Parts Illustration*. Remove drain plug (40), cap with o-ring (25), dipstick (32), and crankshaft key (31) and drain lubricating fluid into a suitable container.
- Remove 12 cap screws (16) and remove back cover (12) and back cover baffle (13).

## Connecting Rod Removal

**Note:** Each of three Connecting rod assemblies (3\*) consists of: connecting rod, connecting rod end cap, sleeve, and two bolts.

- Remove connecting rod assembly bolts (3\*) and remove connecting rod end cap (3\*) with split shell bearing. Make sure numbers on connecting rod and end cap are 'top-up' in the assembly and match.

**Note:** Make sure to note 'top-up' orientation of numbers on connecting rod and end cap when removing. These are matched parts and must be stored together as one assembly and not mixed with any other connecting rod assemblies or parts.

- Set aside connecting rod assembly bolts, end cap, and one half split shell bearing (8) for use in reassembly.
- Remove connecting rod assembly from crankshaft by reaching into rear of crankcase (2) around crankshaft (1). Push connecting rod assembly away from journal on the crankshaft. Move as far forward as possible.
- Repeat removal for three sets.

## Crankshaft Removal

- Remove six cap screws (15) from one side of pump attaching seal and bearing assembly (assembled items 6, 7, 9, 11, 15, 17, and 18) to the crankcase (2).
- Carefully remove crankshaft (1) with seal and bearing assembly from crankcase.
- Remove seal and bearing assembly from end of crankshaft.
- Remove six screws (15) and remaining seal and bearing assembly from crankcase.

## Seal and Bearing Disassembly

- Separate seal and bearing assemblies by removing six cap screws (15).
- Remove O-ring (17) from bearing cover (6). Remove roller bearing (7) from bearing cover.
- Remove O-ring (18) from seal cover (9). Remove two crankshaft seals (11) from seal cover.
- Disassemble two sets.

## Connecting Rod Disassembly

**Note:** Make sure to note 'top-up' orientation of numbers on connecting rod and end cap when storing. These are matched parts and must not be mixed with parts from other connecting rod assemblies.

- Pull out connecting rod/plunger assembly and remove from crankcase.
- Remove remaining one half of split shell bearing (8) from connecting rod (3\*). Match with shell bearing already removed in **Connecting Rod Removal**.
- Retrieve bolts (3\*), and end cap (3\*) from previous step in **Connecting Rod Removal**. Be careful not to mix with parts from other connecting rod assemblies.
- Loosely assemble two bolts, and connecting rod end cap with connecting rod assembly and set aside. Note proper orientation of numbers on connecting rod and end cap.
- Remove setscrew (23) to unlock wrist pin (5). Remove wrist pin, assembled plunger and slider from connecting rod. Note alignment marks on wrist pin and alignment mark on crosshead (4).

- Disassemble and remove three sets.

## Plunger Disassembly

- Remove shoulder screw (29) from plunger assembly to remove plunger (51), spherical washer (27), slider (4), and Belleville spring (28).
- Disassemble three sets as in step a.
- Clean crankcase for later reassembly.

# T100 Series Medium - Power End Service (Cont'd)

## Power End Assembly

 **WARNING:** Crankcase (2) and assembled parts weigh over 600 pounds (272 kg) and are a two man lift. Use care in handling to prevent personal injury or damage to equipment.

## Plunger Assembly

**Note:** The numbers in parentheses are the Reference Numbers shown in the Parts Section of the manual.

- a. Start with crankcase (2) clean and ready to assemble.
- b. Assemble plunger (51), spherical washer (27), slider (4), Belleville spring (28), with shoulder screw (29). Use Loctite 242 and torque to 50 ft-lbs (68 N-m).

**Note:** One concave side of spherical washer assembly (27) mates with plunger (51) and the other convex side of spherical washer assembly mates with slider (4).

- c. Assemble three sets.

## Connecting Rod Assembly

**Note:** Each of three Connecting rod assemblies (3\*) consists of: connecting rod, connecting rod end cap, sleeve, and two bolts.

- a. Attach assembled plunger and slider to connecting rod (3\*) using wrist pin (5). Align marks on wrist pin with marks on slider (4). Lock wrist pin in place with setscrew (23). Use Loctite 271 and torque to 60 in-lbs (7 N-m).

**Note:** Make sure to note 'top-up' orientation of numbers on connecting rod and end cap when taking apart. These are matched parts and must not be mixed with parts from other connecting rod assemblies.

- b. Remove two bolts (3\*) and connecting rod end cap (3\*) from connecting rod assembly. Note orientation numbers on connecting rod and end cap.
- c. Set aside bolts and end cap for later installation. Do not mix with parts from other connecting rod assemblies.
- d. Install one half of split shell bearing (8) on connecting rod. Remaining one half of split shell bearing will be installed later.
- e. Insert connecting rod/plunger assembly into crankcase and push all the way forward. Ensure numbers are "top-up."
- f. Assemble and install three sets.

## Seal and Bearing Assembly

- a. Press two crankshaft seals (11) into seal cover (9). Install O-ring (18) onto seal cover.
- b. Install roller bearing (7) into bearing cover (6). Install O-ring (17) onto bearing cover.
- c. Bolt seal and bearing assemblies together using six cap screws (15).
- d. Assemble two sets.

## Crankshaft Installation

- a. Install one seal and bearing assembly to either side of crankcase (2) using six screws (15). Crankshaft (1) will be installed on opposite side.
- b. Place remaining seal and bearing assembly on following end of crankshaft.

**Note:** No shimming of crankshaft is necessary. End play of crankshaft should be between 0.010 in. minimum to 0.200 in. maximum when installed.

- c. Insert crankshaft with seal and bearing assembly into crankcase and insert into installed seal and bearing assembly on opposite end of crankcase. Align flange of seal and bearing assembly with flange on crankcase.
- d. Bolt flange of seal and bearing assembly to crankcase with six cap screws (15).

## Connecting Rod Installation

**Note:** Each of three Connecting rod assemblies (3\*) consists of: connecting rod, connecting rod end cap, sleeve, and two bolts.

- a. Attach connecting rod assembly to crankshaft (1) by reaching into rear of crankcase around crankshaft and pulling connecting rod assembly until it reaches its journal on the crankshaft.

**Note:** Make sure to note 'top-up' orientation of numbers on connecting rod and end cap when installing. These are matched parts and must not be taken from other connecting rod assemblies.

- b. Retrieve connecting rod assembly bolts, end cap, and remaining split shell bearing (8) set aside in previous steps.
- c. Reinstall connecting rod end cap with remaining split shell bearing using connecting rod assembly bolts. Make sure numbers on connecting rod and end cap are 'top-up' in the assembly and match. Torque two bolts to 100 ft-lbs (136 N-m).
- d. Repeat installation for three sets.

## Crankcase Assembly

**Note:** for torque values refer to the table following the Parts List Section.

- a. Install back cover (12) and back cover baffle (13) using 12 cap screws (16).
- b. Install crankshaft cover (10) on crankshaft end not used with six cap screws (15) used to attach seal and bearing assembly.
- c. If removed, reinstall four studs (20), with four set screws (21), four studs (19), and two eyebolts (14).
- d. Install plug (40), cap with o-ring (25), dipstick (32), and crankshaft key (31) and add lubricating fluid.

# T100 Series Medium - Power End Service (Cont'd)

---

## Float Switch Back Cover Assembly

- a. Align and assemble frame (44), gasket (43), sight glass (42), and thick gasket (41).
- b. Install eight screws (45) alternately through assembled frame into back cover (12) see page 25 for torque values.
- c. Assemble baffle (13) and back cover.
- d. Attach baffle and back cover to crankcase (2) with twelve screws (16) see page 25 for torque values.
- e. Assemble float switch (48) to float switch adapter (47) finger tight plus one half turn.
- f. Assemble float switch adapter with float switch and O-ring (46) into back cover until seated.
- g. Reconnect float switch.

# T100 Series Medium Pressure - Oil Level Monitor

## Oil Level Monitor Float Switch Conditions and Wiring Diagram

**CAUTION:** For pumps certified for use in an explosive atmosphere (ATEX / IECEx) please see supplementary instructions and disregard the wiring instructions in this section.

**CAUTION:** The float switch will only operate with crankshaft rotation in the direction indicated on the pump casting.

**Note:** The numbers in parentheses are the Reference Numbers shown in the Parts Section of the manual.

**Note:** The float switch (48) and adapter (47) can be removed from the back cover without draining the pump's oil. See the Installation and Maintenance sections of the manual for float switch set-up and use.

The float switch (48) monitors the pump's oil level. The switch is used to trigger an alarm or pump shutdown when a high or low oil level is sensed in the pump's crankcase.

The T100 Low Pressure Pump uses one of two float switch (48) configurations. The switch used can be identified by its wire lead colors and part number.

The wiring diagram below shows the operating conditions and wiring colors for each type of switch assembly.

### 1. Normally-Closed (NC) Switch.

The Normally-Closed Float Switch, 177-453-02 (48a) contains two normally-closed (NC) reed switches; one for high oil level, and one for low oil level. The (NC) float switch has solid Black, striped Yellow/White, and striped Red/White wire leads.

### 2. Normally-Open (NO) Switch.

The Normally-Open Float Switch, 177-453-03 (48a) contains two normally-open (NO) reed switches; one for high oil level, and one for low oil level. The (NO) float switch has solid Black, solid Yellow, and solid Red wire leads.

**Note:** The oil level should always be visible between the high and low oil marks viewed on sight glass (42). If the oil level reaches the high or low mark, the float switch will be activated.

## Electrical Specifications

The following are the float switch electrical specifications:

- For P/N 177-453-02 (48a), Normally-Closed (NC) float switch: two single-pole, double-throw (SPDT) reed switches rated at 150 VDC/VAC, 1 Amp, 20 Watts (maximum).
- or  
For P/N 177-453-03 (48a) Normally-Open (NO) float switch: switches rated at 300 VDC/VAC, 0.5 Amp AC/0.7 Amp DC, 50 Watts (maximum).
- Sum total of current for both switches not to exceed: 1 Amp
- Resistive load only
- Magnetic float actuation
- Electrical conduit connection at top of switch adapter: 1/2-14 NPT
- UL File No. E203716 under UL 508.
- Not rated for NEC/CEC hazardous locations. See page 24 for Class I Div 1 switch specs. For ATEX/IECEx applications, please consult factory.**

## Additional Measurement Port

There is a port with plug (49) on the lower left side of the back cover. This port may be used for an additional measurement device.

Float Switch Logic Table						
Setpoint Contacts	177-453-02 (Normally-Closed)			177-453-03 (Normally-Open)		
	Float Down	Float in Middle	Float Up	Float Down	Float in Middle	Float Up
High	Closed	Closed	Open	Open	Open	Closed
Low	Open	Closed	Closed	Closed	Open	Open
Float Switch Wiring						

Oil Level Monitor Float Switch Conditions and Wiring Diagram

# T100 Series Medium - Oil Level Monitor (Cont'd)

## Oil Level Monitor Float Switch Conditions and Wiring Diagram - Class I Division 1

### Wiring Instructions

#### 177-453-05 (48b) Normally-Closed (NC) float switch:

High and Low can be wired individually to different inputs by splitting the common (Black) wire and wiring separately with either the High or Low set-point. Alternatively, both High and Low can be wired in series to a common input without using the common (Black) wire. The ground wire should be connected to nearest common ground.

#### 177-453-06 (48b) Normally-Open (NO) float switch:

High and Low can be wired individually to different inputs by splitting the common (Black) wire and wiring separately with either the High or Low set-point. Alternatively, both High and Low can be wired in parallel by connecting both High and Low leads together to one side of the input and the common (Black) wire to the other side of the input. The ground wire should be connected to nearest common ground.

## Electrical Specifications - Class I Division 1

The following are the maximum electrical rating for Class I Division 1 float switches:

- For P/N 177-453-05 (48b), Normally-Closed (NC) float switch: two single-pole, double-throw (SPDT) reed switches rated at 30 VAC/VDC, 0.2 Amp, 20 Watts (maximum power), 50 Watts (maximum contact rating).  
or  
For P/N 177-453-06 (48b) Normally-Open (NO) float switch: switches rated at 300 VAC/VDC, 0.5 Amp AC/0.7 Amp DC, 50 Watts (maximum power), 3 VA (maximum contact rating).
  - Sum total of current for both switches not to exceed:  
1 Amp
- For both NC and NO switches:**
- UL File No. E203716 under UL 508.
  - Hazardous Area Certifying Body: Factory Mutual, File # 3021242.
  - Hazardous Area Certification: Class I Division 1, Groups A, B, C, D; Class II, Groups E, F, G; Class III, T4 Type 4.
  - Maximum ambient temperature = 300°F (149°C)
  - Maximum gauge pressure = 50 psig (3.5 bar)
  - Resistive load only
  - Magnetic float actuation
  - Electrical conduit connection at top of switch adapter:  
1/2-14 NPT

Class I Division 1 Logic Table						
Setpoint Contacts	177-453-05 (Normally-Closed)			177-453-06 (Normally-Open)		
	Float Down	Float in Middle	Float Up	Float Down	Float in Middle	Float Up
High	Closed	Closed	Open	Open	Open	Closed
Low	Open	Closed	Closed	Closed	Open	Open
Float Switch Wiring						

**Oil Level Monitor Float Switch Conditions and Wiring Diagram**



# T100 Series Medium - Torque Specifications

## Torque Specification Table for the T100K,M

T100K,M Torque Specification Table				
Reference Number	Torque Specification (N-m)	Loctite No.	Part Number	Description
3	100 ft-lbs (136)		177-003-02	Bolts, Connecting Rod Assembly
14	200 ft-lbs (271)		177-059	Eyebolt, M20
15	12 ft-lbs (16)	242	177-048	Screw, Cap, hex-hd, M8, 25 mm
16	12 ft-lbs (16)	242	177-043	Screw, Cap, hex-hd, M8, 15 mm
19	200 ft-lbs (271)	242	177-150	Stud, 27 mm x 300 mm
20	200 ft-lbs (271)	242	177-151	Stud, 27 mm x 300 mm, c-bore 12 mm
23	60 in-lbs (7)	271	G10-082-2010	Screw, Soc-hd, M6, 10 mm
26	450 ft-lbs (610)		177-152	Nut, Hex, M27
29	50 ft-lbs (68)	242	177-047	Screw, Shoulder, M16, 30 mm
45	15 in-lbs (1.7)	271	189-565	Screw, Pan-hd, 10-24
49	#		189-311	Plug, 3/4 in. NPT, SST
50	#		177-459	Plug, 1/2-14 NPT, SST
53	200 ft-lbs (271)	242	177-129-01 177-129-02	Cylinder, K Cylinder, M
56	50 ft-lbs (68)		G10-024-2010	Screw, Cap, soc-hd, M10, 90 mm
57	105 in-lbs (12)		177-905	Cartridge, Overfill valve
61	75 ft-lbs (102)	242	177-906	Cartridge, Air Bleed valve
65	30 ft-lbs (41)		177-904	Cartridge, Underfill valve
72	50 ft-lbs (68)	242	177-358	Retainer, Bias spring
75	12 ft-lbs (16)	271	177-149	Screw, OH
77	75 in-lbs (8)	242	177-050	Screw, Cap, hex-hd, M5, 10 mm
79	80 in-lbs (9)	242	177-176	Screw, Flat-hd, M6 x 1.0 x 16 mm
80	20 ft-lbs (27)	242	177-359	Screw, Flat-hd, M8, 25 mm
88	75 in-lbs (8)		177-052	Screw, Shoulder, M8, 12 mm
91	300 ft-lbs (407)		177-044	Screw, Cap, hex-hd, M20, 50 mm
92	300 ft-lbs (407)		177-116	Screw, Cap, hex-hd, M20, 250 mm
96	40 ft-lbs (54)	*	177-014-01	Plug, Drain

\* Apply Loctite nickel anti-sieze lubricant to threads and chamfer of item 96.

# Apply instant pressure pipe thread sealant.

# T100 Series Medium Pressure - Fluid End Parts

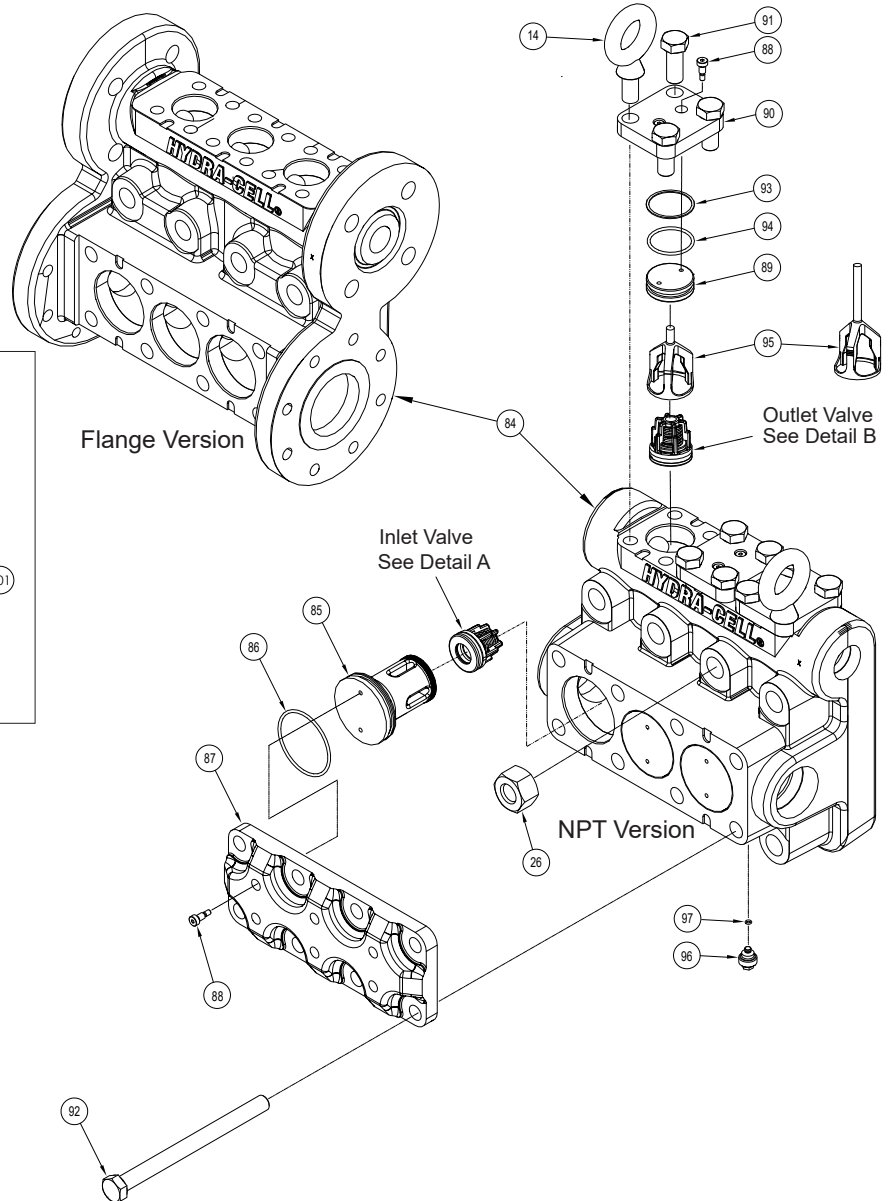
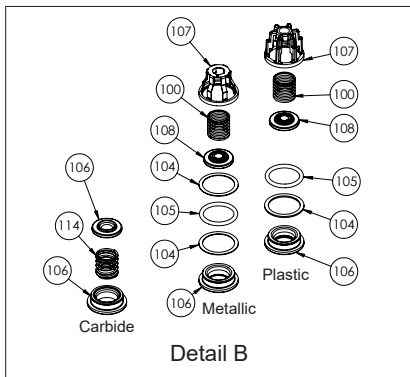
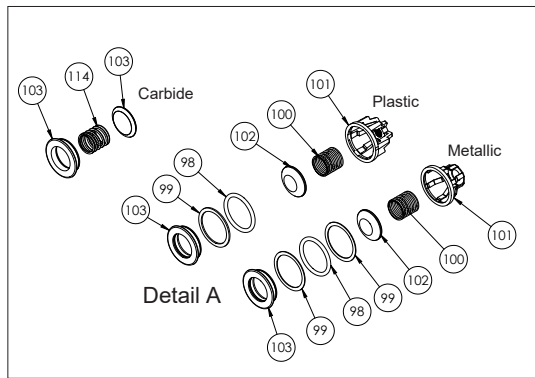
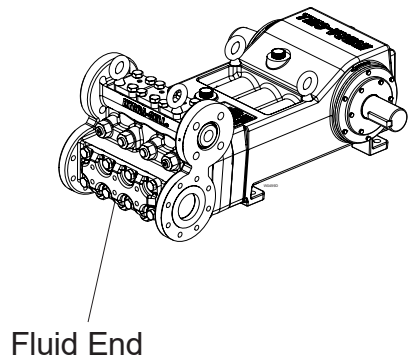

Note: for torque values refer to the Torque Specifications Table.

# T100 Series Medium - Fluid End Parts (Cont'd)

Ref. No.	Part Number	Description	Quantity/ Pump	Ref. No.	Part Number	Description	Quantity/ Pump
14	177-059	Eyebolt, M20 .....	2	102*	177-108-01	Valve Disc, 17-4 SST .....	3
26	177-152	Nut, Hex, M27 .....	8		177-108-02	Valve, Disc, Hastelloy C .....	3
84	177-100-05	Manifold, NAB-NPT .....	1		177-108-05	Valve, Disc, Nitronic .....	3
	177-100-11	Manifold, NAB-flanged .....	1		177-111-01	Valve Assembly, Carbide [includes valve (102) and seat (103)] .....	3
	177-100-12	Manifold, Duplex SST-flanged .....	1	103*	177-102-01	Valve Seat, 17-4 SST .....	3
	177-100-14	Manifold, Austenitic SST-flanged .....	1		177-102-02	Valve Seat, Hastelloy C .....	3
	177-100-20	Manifold, Hastelloy-flanged .....	1		177-102-05	Valve Seat, Nitronic .....	3
85	177-107-03	Plug, Inlet valve support, Austenitic SST .....	3		177-111-01	Valve Assembly, Carbide [includes valve (102) and seat (103)] .....	3
	177-107-04	Plug, Inlet valve support, Duplex SST .....	3	104	177-254-03	Ring, Back-up, PVDF .....	3
	177-107-06	Plug, Inlet valve support, Hastelloy .....	3		177-254-04	Ring, Back-up, PVDF (for metallic spring retainers) .....	6
86	177-127-01	O-ring, Buna-N .....	3	105	177-253-01	O-ring, Buna-N .....	3
	177-127-02	O-ring, FKM .....	3		177-253-02	O-ring, FKM .....	3
	177-127-03	O-ring, EPDM .....	3		177-253-03	O-ring, EPDM .....	3
	177-127-04	O-ring, Aflas .....	3		177-253-04	O-ring, Aflas .....	3
87	177-121-02	Plate, Retainer, inlet .....	1	106*	177-202-01	Valve Seat, 17-4 SST .....	3
88	177-052	Screw, Shoulder, M8, 12 mm .....	12		177-202-02	Valve Seat, Hastelloy C .....	3
89	177-148-01	Plug, Outlet, valve port, Austenitic SST .....	3		177-202-05	Valve Seat, Nitronic .....	3
	177-148-02	Plug, Outlet, valve port, Hastelloy .....	3		177-211-01	Valve Assembly, Carbide [includes valve (108) and seat (106)] .....	3
	177-148-03	Plug, Outlet, valve port, Duplex SST .....	3	107	177-206-01	Retainer, Valve spring, Polypropylene .....	3
90	177-110	Plate, Retainer, discharge cv .....	3		177-206-02	Retainer, Valve spring, PVDF .....	3
91	177-044	Screw, Cap, hex-hd, M20, 50 mm .....	10		177-423-02	Retainer, Valve spring, 316 SST .....	3
92	177-116	Screw, Cap, hex-hd, M20, 250 mm .....	8		177-423-03	Retainer, Valve spring, Hastelloy .....	3
93	177-225-01	Ring, Backup, Buna-N .....	3	108*	177-208-01	Valve Disc, 17-4 SST .....	3
	177-225-02	Ring, Backup, FKM .....	3		177-208-02	Valve Disc, Hastelloy C .....	3
94	177-226-01	O-ring, Buna-N .....	3		177-208-05	Valve Disc, Nitronic .....	3
	177-226-02	O-ring, FKM .....	3		177-211-01	Valve Assembly, Carbide [includes valve (108) and seat (106)] .....	3
	177-226-03	O-ring, EPDM .....	3	114*	D40-022-3118	Spring, Elgiloy .....	6
	177-226-04	O-ring, Aflas .....	3		D40-022-3119	Spring, Hastelloy .....	6
95	177-146-03	Retainer, Outlet, NPT Austenitic SST .....	3				
	177-146-05	Retainer, Outlet, flanged Austenitic SST .....	3				
	177-146-06	Retainer, Outlet, flanged Duplex SST .....	3				
	177-146-07	Retainer, Outlet, flanged Hastelloy .....	3				
96	177-014-01	Plug, Drain, 316 SST .....	3				
	177-014-02	Plug, Drain, Hastelloy .....	3				
	177-014-03	Plug, Drain, Duplex 2205 .....	3				
97	D10-047-2110	O-ring, Buna-N .....	3				
	D10-047-2111	O-ring, FKM .....	3				
98	177-053-01	O-ring, Buna-N .....	3				
	177-053-02	O-ring, FKM .....	3				
99	177-054-03	Ring, Back-up, PVDF .....	3				
	177-054-04	Ring, Back-up, PVDF (for metallic spring retainers) .....	6				
100	177-109-01	Spring, Elgiloy .....	6				
	177-109-02	Spring, Hastelloy .....	6				
101	177-106-01	Retainer, Valve spring, Polypropylene .....	3				
	177-106-02	Retainer, Valve spring, PVDF .....	3				
	177-422-02	Retainer, Valve spring, 316 SST .....	3				
	177-422-03	Retainer, Valve spring, Hastelloy .....	3				

\* Tungsten Carbide valve seat and disc are a matched set and must be installed together.

# T100 Series Medium - Hydraulic Section Parts

Note: S/N 436513 and lower - standard diaphragms.  
 S/N 436514 and higher - upgraded diaphragms.

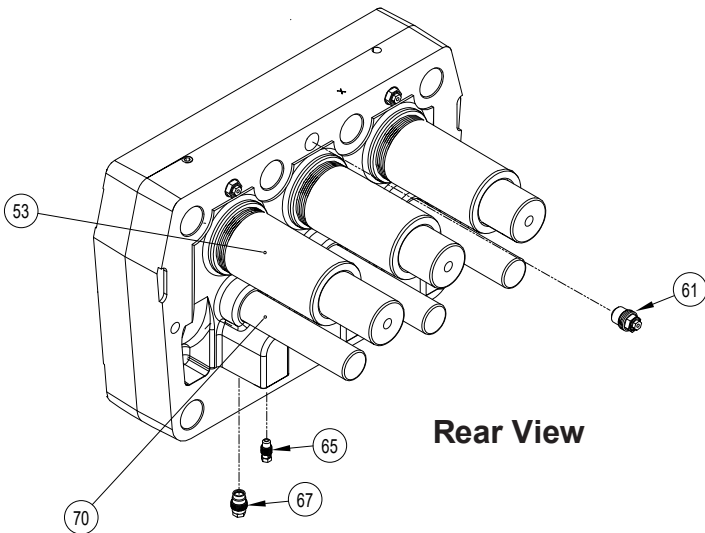
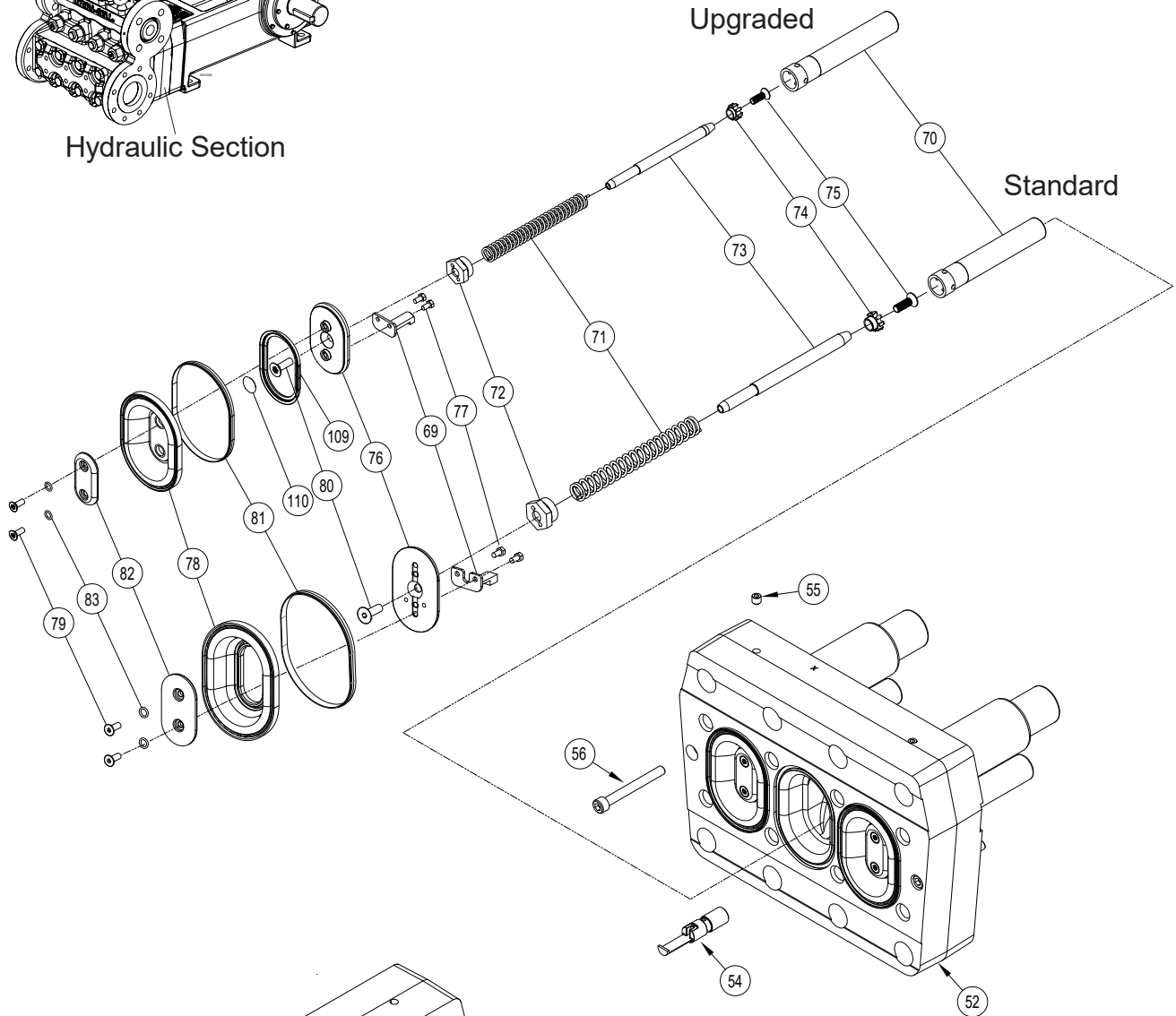
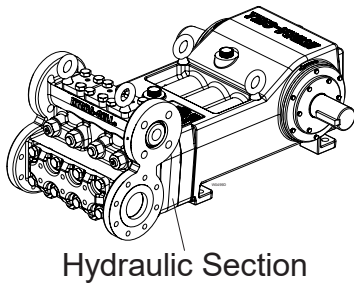

Note: For torque values refer to the Torque Specifications Table.

# T100 Medium - Hydraulic Section Parts (Cont'd)

Ref. No.	Part Number	Description	Quantity/ Pump
52	177-101-02	Diaphragm Plate .....	1
53	177-129-01	Cylinder, K.....	3
	177-129-02	Cylinder, M .....	3
54	177-009	Spool, Valve .....	3
55	177-117	Setscrew, M10, 10 mm .....	2
56	G10-024-2010	Screw, Cap, soc-hd, M10, 90 mm .....	2
57	177-905	Cartridge, Overfill valve .....	3
61	177-906	Cartridge, Air Bleed valve .....	3
65	177-904	Cartridge, Underfill valve .....	3
69	177-145	Arm, Valve .....	3
	177-192	Arm, Valve (upgraded) .....	3
70	177-356	Tube, Valve.....	3
71	177-183	Spring, Bias.....	3
	177-195	Spring, Bias (upgraded) .....	3
72	177-358	Cap, Bias tube.....	3
73	177-355	Rod, Bias spring .....	3
	177-194	Rod, Bias spring (upgraded) .....	3
74	177-312	Guide, Spring .....	3
75	177-149	Screw, M8, 25 mm, OHMS .....	3
76	177-190	Clamp, Diaphragm .....	3
	177-168	Clamp, Diaphragm (upgraded).....	3
77	177-050	Screw, Cap, hex-hd .....	6
78	177-185-01	Diaphragm, Buna-N .....	3
	177-185-02	Diaphragm, FKM .....	3
	177-185-03	Diaphragm, EPDM .....	3
	177-185-04	Diaphragm, Aflas.....	3
	177-188-01	Diaphragm, Buna-N (upgraded).....	3
	177-188-02	Diaphragm, FKM (upgraded) .....	3
	177-188-03	Diaphragm, EPDM (upgraded).....	3
	177-188-04	Diaphragm, Aflas (upgraded).....	3
79	177-176-01	Screw, FHSS, Austenitic SST .....	6
	177-176-02	Screw, FHSS, Hastelloy.....	6
	177-176-03	Screw, FHSS, Duplex SST.....	6
80	177-359	Screw, Flat-hd, M8-6g x 25 mm.....	3
81	177-167	Ring, Diaphragm, back-up .....	3
82	177-186-01	Follower, Austenitic SST .....	3
	177-186-02	Follower, Hastelloy .....	3
	177-186-03	Follower, Duplex SST.....	3
	177-193-01	Follower, Austenitic SST (upgraded)...	3
	177-193-02	Follower, Hastelloy (upgraded).....	3
	177-193-03	Follower, Duplex SST (upgraded) .....	3
83	100-217-01	O-ring, Buna-N.....	6
	100-217-02	O-ring, FKM .....	6
	100-217-03	O-ring, EPDM.....	6
	100-217-04	O-ring, Aflas .....	6
109	177-169	Support, Ring (upgraded).....	3
110	177-642	Plug, Screw Head (upgraded).....	3

# T100 Series Medium Pressure - Power End Parts

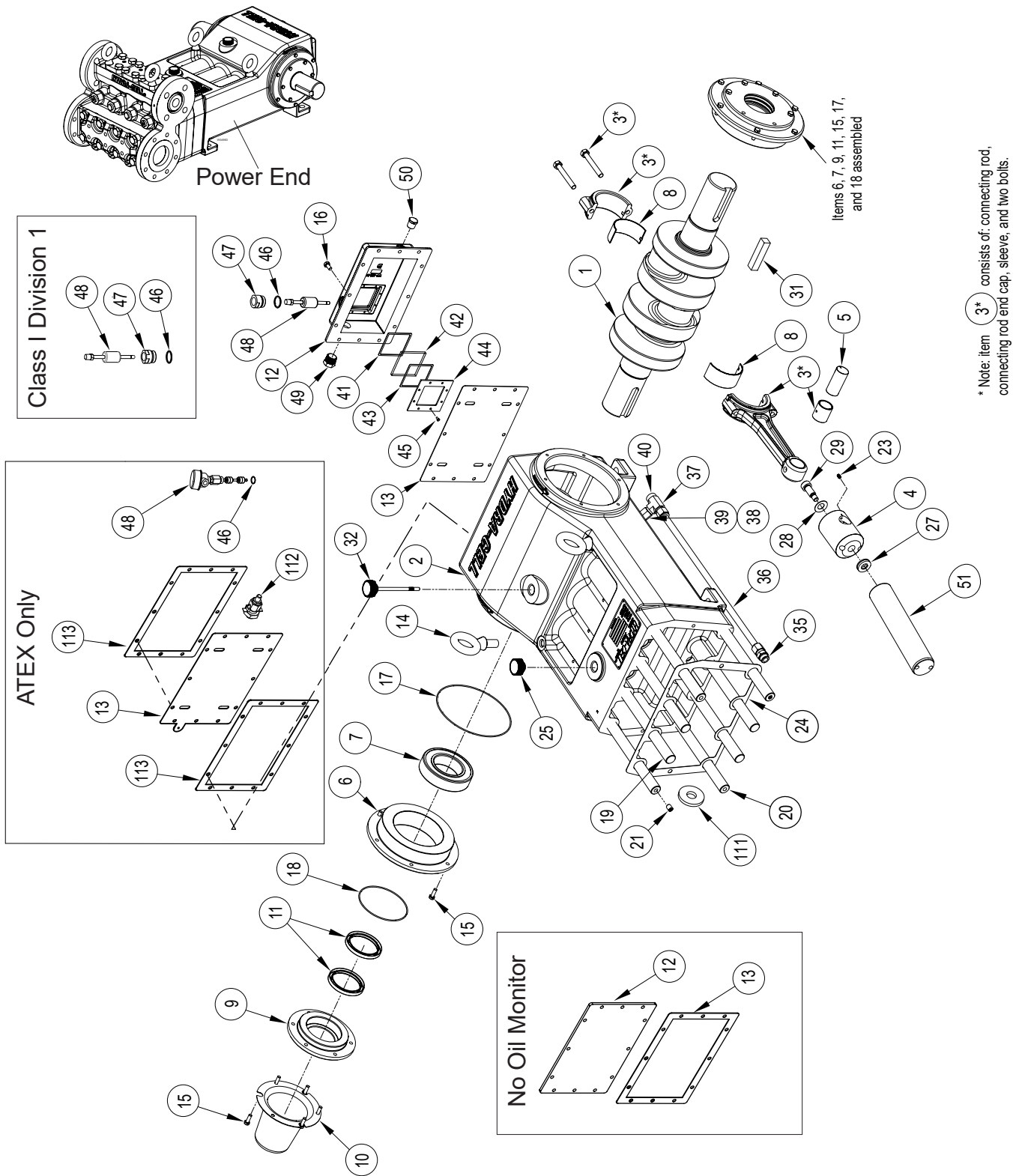

Note: for torque values refer to the Torque Specifications Table.

# T100 Series Medium - Power End Parts (Cont'd)

Ref. No.	Part Number	Description	Quantity/ Pump
1	177-002-06	Crankshaft, Forged .....	1
2	177-001-02	Crankcase .....	1
3	177-003-02	Connecting Rod Assembly.....	3
4	177-005	Slider .....	3
5	177-032	Pin, Wrist.....	3
6	177-021	Cover, Bearing .....	2
7	177-027	Bearing, Roller, spherical.....	2
8	177-041	Bearing, Split shell (pair).....	3
9	177-034	Cover, Seal.....	2
10	177-035	Cover, Crankshaft .....	1
11	177-028	Seal, Crankshaft.....	4
12	177-450-02	Cover, Float switch (Oil Monitor).....	1
13	177-451	Baffle, Float switch (Oil Monitor).....	1
14	177-059	Eyebolt, M20 .....	2
15	177-048	Screw, Cap, hex-hd, M8, 25 mm.....	24
16	177-043	Screw, Cap, hex-hd, M8, 15 mm.....	12
17	H25-037-2110	O-ring, Buna-N.....	2
18	D10-109-2110	O-ring, Buna-N.....	2
19	177-150	Stud, 27 mm x 300 mm .....	4
20	177-151	Stud, 27 mm x 300 mm, c-bore 12 mm ..	4
21	177-118	Setscrew, M12, 15 mm .....	4
23	G10-082-2010	Setscrew, M6, 10 mm.....	3
24	177-013	Gasket, Diaphragm plate .....	1
25	D03-039-1030	Cap, Oil fill (with o-ring).....	1
27	177-031	Washer, Spherical .....	3
28	177-030	Spring, Belleville.....	3
29	177-047	Screw, Shoulder, M16, 30 mm .....	3
31	177-036	Key, Crankshaft.....	1
32	177-912	Dipstick.....	1
35	209-701	Fitting, 5/8 Tube .....	1

## ATEX Specific Parts

Ref. No.	Part Number	Description	Quantity/ Pump
13	177-451-01	Baffle, Float switch, ATEX (oil monitor) .....	1
46	D03-075-2110	O-Ring, Buna-N .....	1
48	177-453-01	Switch, Float, ATEX, discrete.....	1
	177-453-04	Switch, Float, ATEX, 4-20 mA .....	1
112	177-462	Stud, earth grounding .....	1
113	177-026	Gasket, Back cover, ATEX.....	2

Ref. No.	Part Number	Description	Quantity/ Pump
36	209-711	Tube, 5/8 x 22 1/2 x .049.....	1
37	209-710	Fitting, Flareless tube.....	1
38	209-712	Tube, 1 7/8 X .049 .....	1
39	209-702	Fitting, 90° Elbow .....	1
40	189-313	Plug, 1/2 in. NPT .....	1
41	177-456	Gasket, Sight glass, thick.....	1
42	177-454	Glass, Sight.....	1
43	177-452	Gasket, Sight glass .....	1
44	177-455	Frame, Sight glass .....	1
45	189-565	Screw, 10-24 pan-hd.....	8
46	D03-075-2110	O-Ring, Buna-N .....	1
47	177-457	Adapter, Float switch.....	1
48	177-453-02	Switch, Float, normally closed .....	1
	177-453-03	Switch, Float, normally open.....	1
49	189-311	Plug, 3/4 NPT, SST .....	1
50	177-459	Plug, 1/2-14 NPT, SST .....	1
51	177-103-01	Plunger, K.....	3
	177-103-02	Plunger, M .....	3
111	211-055	Magnet, Ceramic Ring .....	2

## Class I Div 1 Specific Parts

Ref. No.	Part Number	Description	Quantity/ Pump
46	D03-075-2110	O-Ring, Buna-N .....	1
47	177-461	Adapter, Float switch, Class I, Div 1 ...	1
48	177-453-05	Switch, Float, Class I Div 1, NC .....	1
	177-453-06	Switch, Float, Class I Div 1, NO .....	1

## No Oil Monitor Specific Parts

Ref. No.	Part Number	Description	Quantity/ Pump
12	177-022	Cover, Back (no Oil Monitor).....	1
13	177-026	Gasket, Back cover (no Oil Monitor) ...	1

# T100 Series Medium Pressure - Troubleshooting

## Cavitation

- Inadequate fluid supply because:
  - Inlet line collapsed or clogged
  - Clogged line strainer
  - Inlet line too small or too long
  - Air leak in inlet line
  - Worn or damaged inlet hose
  - Suction line too long
  - Too many valves and elbows in inlet line
- Fluid too hot for inlet suction piping system
- Air entrained in fluid piping system
- Aeration and turbulence in supply tank
- Inlet vacuum too high (refer to “Inlet Calculations” paragraph)

## Symptoms of Cavitation

- Excessive pump valve noise
- Premature failure of spring or retainer
- Volume or pressure drop
- Rough-running pump
- Premature failure

## Drop in Volume or Pressure

A drop in volume or pressure can be caused by one or more of the following:

- Air leak in suction piping
- Clogged suction line or suction strainer
- Suction line inlet above fluid level in tank
- Inadequate fluid supply
- Pump not operating at proper Rpm
- Relief valve bypassing fluid
- Worn pump valve parts
- Foreign material in inlet or outlet valves
- Loss of oil prime in cells because of low oil level
- Ruptured diaphragm
- Cavitation
- Warped manifold from overpressurized system
- O-rings forced out of their grooves from overpressurization
- Air leak in suction line strainer or gasket
- Cracked suction hose
- Empty supply tank
- Excessive aeration and turbulence in supply tank
- Worn and slipping drive belt(s)
- Worn spray nozzle(s)
- Cracked cylinder

## Pump Runs Rough

- Worn pump valves
- Air lock in outlet system
- Oil level low
- Wrong viscosity of oil for cold operating temperatures (change to lighter weight)
- Cavitation
- Air in suction line
- Restriction in inlet/suction line
- Hydraulic cells not primed after changing diaphragm
- Foreign material in inlet or outlet valve
- Damaged diaphragm
- Fatigued or broken valve spring

## Premature Failure of Diaphragm

- Frozen pump
- Puncture by a foreign object
- Elastomer incompatible with fluid being pumped
- Pump running too fast
- Excess pressure
- Cavitation
- Aeration or turbulence in supply tank

## Valve Wear

- Normal wear from high-speed operation
- Cavitation
- Abrasives in the fluid
- Valve incompatible with corrosives in the fluid
- Pump running too fast

## Loss of Oil

- External seepage
- Rupture of diaphragm
- Frozen pump
- Worn shaft seal
- Oil drain plug or fill cap loose
- Valve plate and manifold bolts loose

## Premature Failure of Valve Spring or Retainer

- Cavitation
- Foreign object in the pump
- Pump running too fast
- Spring/retainer material incompatible with fluid being pumped
- Excessive inlet pressure



# T100 Series Medium - Tool Kit and Pump Storage

## T100 Medium Pressure Tool Kit

The T100 Medium Pressure Tool Kit (Part No. 177-800) contains the tools illustrated below. These tools are used to assist in the repair and maintenance of the T100K and T100M. See the maintenance sections of this manual for specific application.

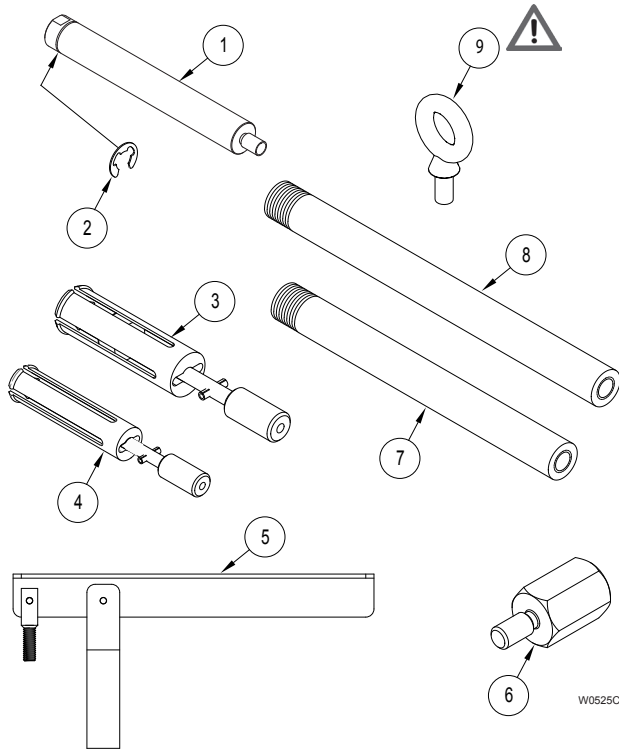

**! WARNING:** Item 9, M10 Diaphragm Plate Eyebolt is used to lift Diaphragm Plate (52) only. Do not use to lift entire pump. Attempting to lift entire pump with Eyebolt (9) may cause personal injury or damage to equipment.

Ref. No.	Tool Part No.	Tool Description	Quantity/Kit
1	177-393	Stud Extender .....	4
2	177-392	Clip, E-style .....	4
3	177-910	Check Valve Extractor .....	1
4	177-915	Check Valve Extractor.....	1
5	A03-124-1200	Check Valve Extractor Lever .....	1
6	177-157	Thread Adapter, Check Valve Extractor to Slide Hammer .....	1
7	177-136	Outlet Check Valve Extractor, NPT.....	1
8	177-140	Outlet Check Valve Extractor, Flange .....	1
9	177-058	Eyebolt, M10.....	2

## Pump Storage for T100 Medium Pressure

**CAUTION:** If the pump is to be stored more than six months take the following steps to protect against corrosion:

### After Shut Down of the pump:

1. Drain all process fluid from pump. Fill the oil reservoir completely to the top with the correct lubricant. Do not drain oil from the pump.

**CAUTION - Do not store the pump without oil in the reservoir.**

2. Flush the fluid end of the pump with a corrosion inhibitor that is compatible with the diaphragm material and process fluid.
3. Coat camshaft or crankshaft with rust preventative; wrap with wax-impregnated cloth and then with waterproof tape.
4. Plug the suction and discharge ports of the pump to protect against dirt and moisture.
5. Store in a clean, dry place.

### Prior to Start-up of the pump:

1. Drain and refill the hydraulic end of the pump with the appropriate Hydra-Oil.

# T100 Medium - Replacement Parts Kits

TO ORDER REPLACEMENT PARTS KIT: A Replacement Parts Kit contains 12 digits corresponding to customer-specified design options.

1	2	3	4	5	6	7	8	9	10	11	12
---	---	---	---	---	---	---	---	---	----	----	----

Digit	Order Code	Description
1-4	<b>T100</b>	<b>Pump Configuration</b> For all T100 Series Pumps
5	<b>M</b>	<b>Performance</b> Medium Pressure (T100K, T100M)
6	<b>D</b> <b>V</b>	<b>Kit Designator</b> Diaphragm Kit Valve Kit
7	<b>5</b> <b>6</b>	<b>Pump Head Material</b> Metallic Pump Head Version Metallic Pump Head Version - upgraded diaphragm with support ring (Diaphragm Kit only)
8	<b>A</b> <b>E</b> <b>G</b> <b>T</b>	<b>Diaphragm &amp; O-ring Material</b> Aflas EPDM FKM Buna-N
9	<b>D</b> <b>H</b> <b>N</b> <b>T</b> <b>X</b>	<b>Valve Seat Material</b> Tungsten Carbide† 17-4 Stainless Steel Nitronic 50 Hastelloy C Not included in Diaphragm Kit
10	<b>D</b> <b>F</b> <b>N</b> <b>T</b> <b>X</b>	<b>Valve Material</b> Tungsten Carbide† 17-4 PH Stainless Steel Nitronic 50 Hastelloy C Not included in Diaphragm Kit
11	<b>E</b> <b>T</b> <b>X</b>	<b>Valve Springs</b> Elgiloy Hastelloy C Not included in Diaphragm Kit
12	<b>M</b> <b>P</b> <b>S</b> <b>T</b> <b>X</b>	<b>Valve Spring Retainers</b> PVDF Polypropylene 316 SST Hastelloy C Not included in Diaphragm Kit

† Tungsten Carbide valve seat and disc are a matched set and must be purchased together.

T100 Medium Pressure Kit D Contents		
Part Number*	Description	Quantity
177-185-__	Diaphragm	3
or 177-188__	Diaphragm (upgraded)	
177-167	Ring, Back-up, Polypropylene	3
100-217-__	O-ring	6
177-176-__	Screw, M6	6
177-642	Plug, Screw Head (upgraded)	3
177-169	Support, Ring (upgraded)	3

S/N 436513 and lower - standard diaphragms.  
S/N 436514 and higher - upgraded diaphragms.

T100 Medium Pressure Kit V Contents		
Part Number*	Description	Quantity
177-102-__	Valve Seat	3
or 177-111-01	Valve Assembly, Carbide (includes valve seat) †	
177-054-03	Ring, Back-up, PVDF (for non-metallic retainers)	3
or 177-054-04	Ring, Back-up, PVDF (for metallic retainers)	6
177-053-__	O-ring	3
177-108-__	Valve Disc	3
or 177-111-01	Valve Assembly, Carbide (includes valve disc) †	
177-109-__	Spring	6
177-106-__	Retainer, Valve spring, non-metallic	3
or 177-422-__	Assembly, spring retainer, metallic	
177-202-__	Valve Seat	3
or 177-211-01	Valve Assembly, Carbide (includes valve seat) †	
177-254-03	Ring, Back-up, PVDF (for non-metallic retainers)	3
or 177-254-04	Ring, Back-up, PVDF (for metallic retainers)	6
177-253-__	O-ring	3
177-208-__	Valve Disc	3
or 177-211-01	Valve Assembly, Carbide (includes valve disc) †	
177-206-__	Retainer, Valve spring, non-metallic	3
or 177-423-__	Assembly, spring retainer, metallic	
177-127-__	O-ring	3
177-225-__	Ring, Back-up	3
177-226-__	O-ring	3

\* Last two digits of part numbers with \_\_ refer to specific material of construction.

Hydra-Cell® is a registered trademark of Wanner Engineering, Inc.  
Aflas® is a registered trademark of Asahi Glass Co., Ltd.  
Buna®-N (Nitrile) is a registered trademark of E.I. Du Pont de Nemours and Company, Inc.  
Elgiloy® is a registered trademark of Elgiloy Limited Partnership.  
Hastelloy® C is a registered trademark of Haynes International, Inc.  
Nitronic® 50 is a registered trademark of AK Steel Corporation.

# T100 Medium - Replacement Parts Kits (Cont'd)

## T100 Medium Hydraulic End Kit Contents (Part No. 177-801)

Part Number	Description	Quantity
177-802	Bias Rod Assembly	3
177-906	Valve, Air bleed	3
177-904	Valve, Underfill	3
177-905	Valve, Overfill	3
177-009	Valve, Spool	3
177-013	Gasket, Diaphragm plate	1

## T100 Medium Pressure Bias Rod Assembly Kit Contents (Part No. 177-802)

Part Number	Description	Quantity
177-149	Screw, M8	1
177-312	Guide, Spring	1
177-355	Rod, Bias spring	1
177-183	Spring, Bias	1
177-050	Screw, M5	2
177-145	Arm, Valve	1
177-190	Clamp, Diaphragm	1
177-359	Screw, M8	1

## T100 Medium Pressure Hydraulic End Kit Contents (Upgraded)

(Part No. 177-818)

Part Number	Description	Quantity
177-819	Bias Rod Assembly	3
177-906	Valve, Air Bleed	3
177-904	Valve, Underfill	3
177-905	Valve, Overfill	3
177-009	Valve, Spool	3
177-013	Gasket, Diaphragm plate	1

## T100 Medium Pressure Upgrade Kits

Kit Part No. Diaphragm Material

177-919	FKM
177-920	Buna-N

Part Number\*\* Description Quantity

177-176-01	Screw, M6, FHSS	6
100-217-__	O-ring	6
177-193-01	Follower, 316 SST	3
177-188-__	Diaphragm	3
177-167	Ring, back-up	3
177-149	Screw, M8, OHMS	3
177-312	Guide, spring	3
177-194	Rod, bias	3
177-195	Spring, bias	3
177-050	Screw, M5	6
177-192	Arm, valve	3
177-169	Support Ring	3
177-168	Clamp, Diaphragm	3
177-359	Screw, M8	3
177-642	Plug, screw head	3
177-191	Name Plate, diaphragm kit	1
177-180	Screw, M10	1

\*\* Last two digits of part numbers with \_\_ refer to specific material of construction.

## T100 Medium Pressure Bias Rod Assembly Kit Contents (Upgraded)

(Part No. 177-819)

Part Number	Description	Quantity
177-149	Screw, M8	1
177-312	Guide, Spring	1
177-194	Rod, Bias spring	1
177-195	Spring, Bias	1
177-050	Screw, M5	2
177-192	Arm, Valve	1
177-169	Support, Ring	1
177-168	Clamp, Diaphragm	1
177-359	Screw, M8	1
177-642	Plug, Screw head	1

# T100 Series - Warranty

## Limited Warranty

Wanner Engineering, Inc. ("Wanner") extends to the original purchaser of equipment supplied or manufactured by Wanner and bearing its name, a limited one-year warranty from the date of purchase against defects in material or workmanship, under normal use and service, and provided the equipment is installed, operated and maintained in accordance with instructions supplied by Wanner. Wanner will repair or replace, at its option, defective parts without charge if: (a) you provide written notice of any defect within thirty (30) days from the discovery of the defect; (b) the claim is received by Wanner before the expiration of the warranty period; and (c) such parts are returned with transportation charges prepaid to Wanner Engineering, Inc., 1204 Chestnut Avenue, Minneapolis, Minnesota 55403. A return goods authorization must be received prior to the return of the defective part. No allowance will be made for repairs undertaken without Wanner written consent or approval.

Notwithstanding anything to the contrary, this warranty does not cover:

1. Electric motors (if applicable) not manufactured by Wanner. The warranties, if any, on such equipment are assigned to you by Wanner (without recourse) at the time of purchase.
2. Normal wear and/or damage caused by or related to abrasion, corrosion, abuse, negligence, accident, faulty installation or tampering which impairs normal operation.
3. Transportation costs.

This limited warranty is exclusive, and is in lieu of any other warranties (oral, express, implied or statutory) including, but not limited to, implied warranties of merchantability and fitness for a particular purpose; warranties of non-infringement; warranties arising from course of dealing or usage of trade or any other matter. Any descriptions of the equipment, drawings, specifications, and any samples, models, bulletins, or similar material used in connection with the sale of equipment are for the sole purpose of identifying the equipment and are not to be construed as an express warranty that the equipment will conform to such description. Any field advisory or installation support is advisory only. Every form of liability for direct, special, incidental or consequential damages or loss is expressly excluded and denied. All liability of Wanner shall terminate one (1) year from the date of purchase of the equipment.



**Wanner Engineering, Inc.**

## World Headquarters & Manufacturing

Wanner Engineering, Inc  
1204 Chestnut Avenue,  
Minneapolis, MN 55403 USA  
Phone: 612-332-5681 • Fax: 612-332-6937  
Toll-Free Fax (USA): 800-332-6812  
Email: sales@wannereng.com  
www.Hydra-Cell.com

207 US Highway 281  
Wichita Falls, TX 76310 USA  
Phone: 940-322-7111  
Toll-Free Fax: 800-234-1384  
Email: sales@wannereng.com  
www.Hydra-Cell.com

## Latin American Office

São Paulo, Brazil  
Phone: +55 (11) 4081-7098  
Email: sales@wannereng.com  
www.Hydra-Cell-Pumps.com.br



**Wanner International Ltd.**

Wanner International Ltd  
Hampshire - United Kingdom  
Phone: +44 (0) 1252 816847  
Email: sales@wannerint.com  
www.Hydra-Cell.co.uk



**Wanner Pumps Ltd.**

Wanner Pumps Ltd.  
Kowloon - Hong Kong  
Phone: +852 3428 6534  
Email: sales@wannerpumps.com  
www.WannerPumps.com

Shanghai - China  
Phone: +86-21-6876 3700  
Email: sales@wannerpumps.com  
www.WannerPumps.com