

Q330 PRO SERIES HIGH PRESSURE

Maximum Flow Rate: 117 gpm (442 l/min) 4011 BPD
Maximum Pressure: 4500 psi (310 bar)

 **WANNER™** HYDRA-CELL® PRO
SEAL-LESS PUMP TECHNOLOGIES

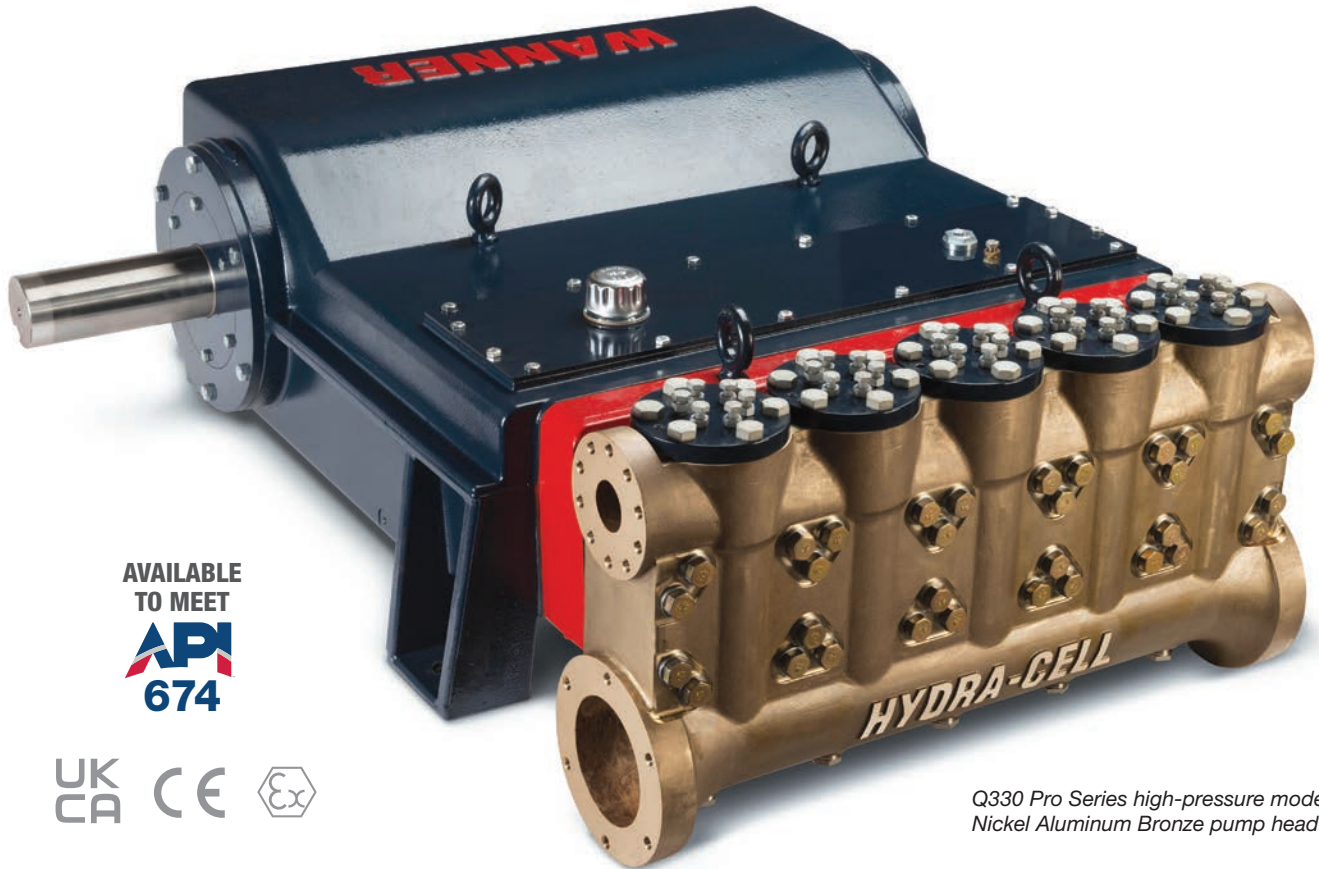

AVAILABLE
TO MEET

674

UK
CA  

*Q330 Pro Series high-pressure model with
Nickel Aluminum Bronze pump head.*

High-pressure performance with exclusive low-pulse, linear flow that reduces pump energy costs and stress.

- Seal-less design separates the power end from the process fluid end, eliminating leaks, hazards, and the expense associated with seals and packing.
- Low NPSH requirements allow for operation with a vacuum condition on the suction – positive suction pressure is not necessary.
- Can operate with a closed or blocked suction line and run dry indefinitely without damage, eliminating downtime and repair costs.
- Unique diaphragm design handles more abrasives with less wear than gear, screw or plunger pumps.
- Hydraulically balanced diaphragms to handle high pressures with low stress.
- Lower energy costs than centrifugal pumps and other pump technologies.
- Rugged construction for long life with minimal maintenance.
- Compact design provides a variety of installation options.
- Available to meet API 674



WANNER™

Q330 Pro High Pressure | Performance

Capacities

Model	Max. Input rpm	Plunger Dia.		Max. Flow Capacities			Max. Pressure Ratings Discharge		Inlet	
		inches	mm	gpm	l/min	BPD	psi	bar	psi	bar
Q330P	400	2.000	51	117	442	4011	4000	276	500	34
Q330Q	400	1.875	48	104	393	3566	4500	310	500	34

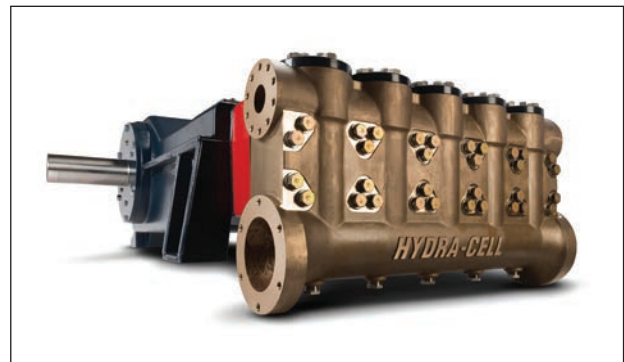
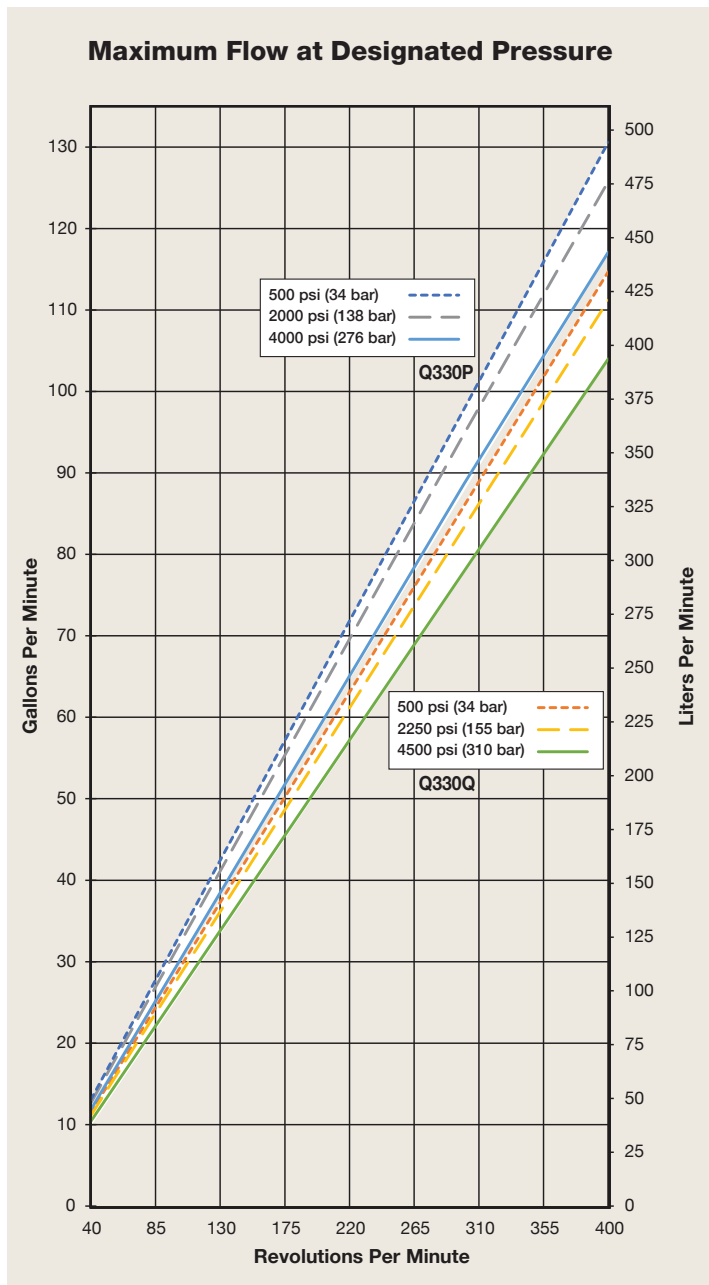
Consult factory when operating below 40 rpm



Q330 Pro Series pumps feature the Hydra-Cell seal-less design, eliminating clean-up costs from leaking seals or packing and protecting operators from dangerous fluids such as those containing hydrogen sulfide.

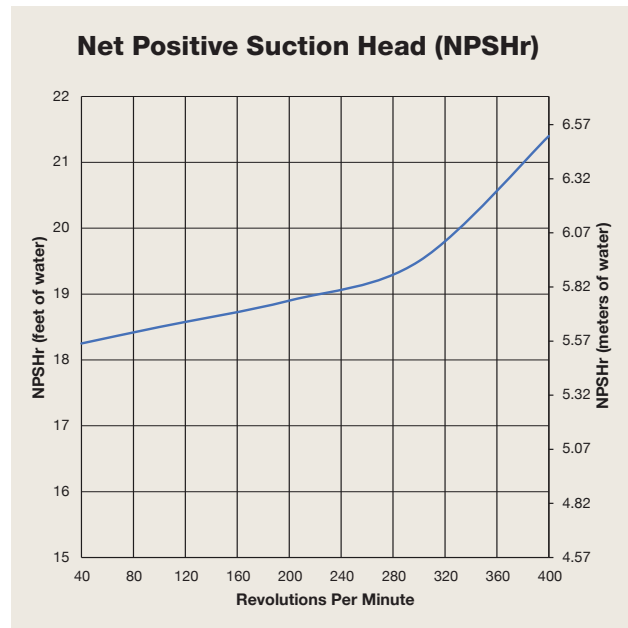

Due to the Wanner Engineering Continuous Improvement Program, specifications and other data are subject to change.

Q330 Pro High Pressure | Specifications

Flow Capacities

Model	Pressure psi (bar)	rpm	gpm	l/min	BPD
Q330P	4000 (276)	400	118	446	4047
Q330Q	4500 (310)	400	104	393	3567

Delivery

	Pressure psi (bar)	gal/rev	liters/rev
Q330P	500 (34)	0.327	1.236
	2000 (138)	0.316	1.197
	4000 (276)	0.296	1.119
Q330Q	500 (34)	0.287	1.085
	2250 (155)	0.278	1.052
	4500 (310)	0.260	0.984

rpm

Maximum:	400
Maximum API 674:	310
Minimum:	40

Consult factory for speeds less than 40 rpm.

Maximum Discharge Pressure

Metallic Heads:	Q330P	4000 psi (276 bar)
	Q330Q	4500 psi (310 bar)

Maximum Inlet Pressure

500 psi (34 bar)

Operating Temperature

Maximum:	180°F (82.2°C)
Minimum:	40°F (4.4°C)

Consult factory for temperatures outside this range.

Maximum Solids Size

800 microns

Input Shaft

Right Side

Inlet Ports

Weld-On: 6 inch / SCH. 40
6 inch NPT, 6 inch Class 300 RF ANSI

Discharge Ports

Weld-On: 3 inch / SCH. XXH
3 inch NPT, 3 inch Class 2500 RTJ ANSI

Plunger Stroke Length

5 inch (127 mm)

Shaft Diameter

4 inch (101.6 mm)

Shaft Rotation

Uni-directional (See rotation arrow.)

Oil Capacity

110 US quarts (104.1 liters)

Calculating Required Horsepower (kW)*

$$\frac{\text{gpm} \times \text{psi}}{1,460} = \text{electric motor hp}^*$$

$$\frac{\text{lpm} \times \text{bar}}{511} = \text{electric motor kW}^*$$

* hp (kW) is required application power.

Attention!

When sizing motors with variable speed drives (VFD): It is very important to select a motor and a VFD rated for constant torque inverter duty service and that the motor is rated to meet the torque requirements of the pump throughout desired speed range.

Weight

Metallic Heads: 5000 lbs. (2268 kg)

Fluid End Materials

Manifold:	Nickel Aluminum Bronze (NAB)
Diaphragm/Elastomers:	FKM Buna-N
Diaphragm Follower Screw:	316 Stainless Steel
Valve Spring Retainer:	Hastelloy C
Check Valve Spring:	Elgiloy Hastelloy C
Valve Disc/Seat:	17-4 Stainless Steel Nitronic 50 Hastelloy C
Outlet Valve Retainer:	316 Stainless Steel
Plug-Outlet Valve Port:	316 Stainless Steel
Inlet Valve Retainer:	316 Stainless Steel

Power End Materials

Crankshaft:	Ductile Iron
Connecting Rods:	Ductile Iron
Crossheads:	Ductile Iron
Crankcase:	Ductile Iron
Bearings:	Spherical Roller Journal (outer mains) Steel Backed Tri-metal (crankpin) Bronze (wristpin, center mains)

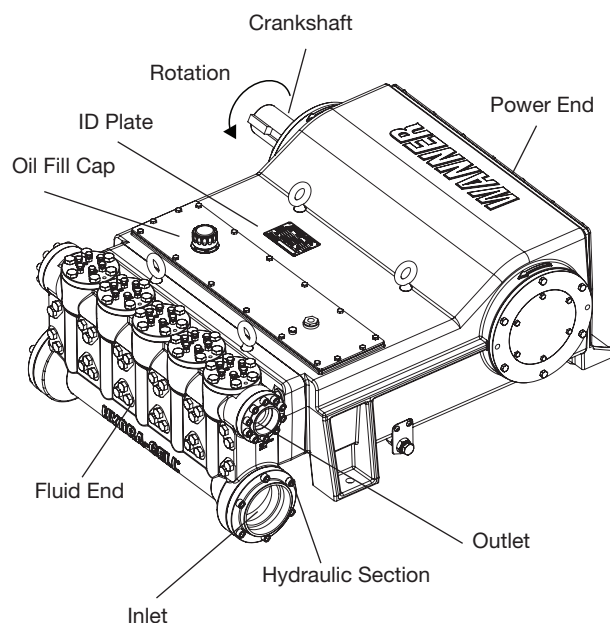

Due to the Wanner Engineering Continuous Improvement Program, specifications and other data are subject to change.

Q330 Pro High Pressure | Drawings

Threaded Version Inches (mm)

Front View

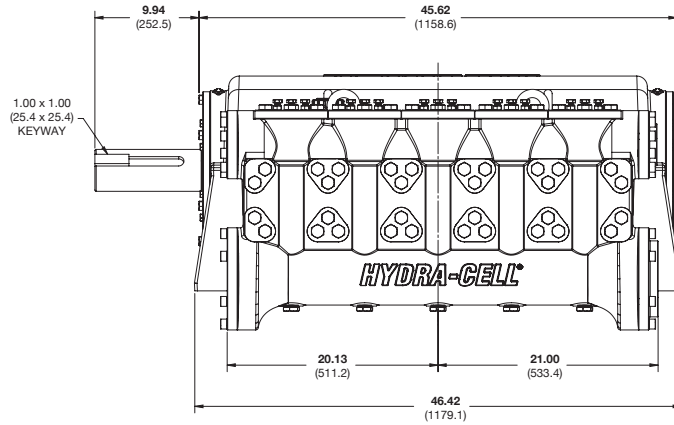

Side View

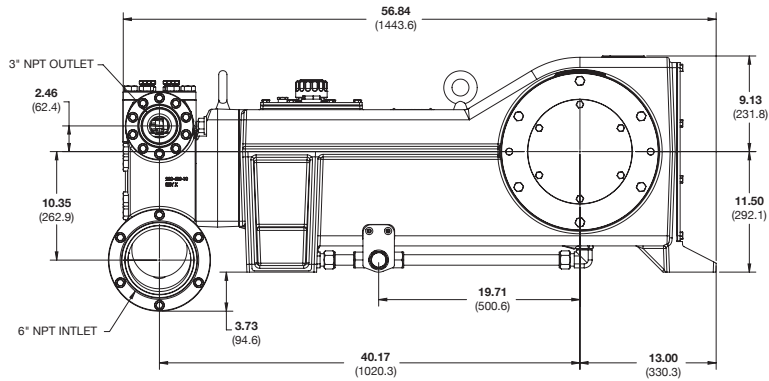

Bottom View

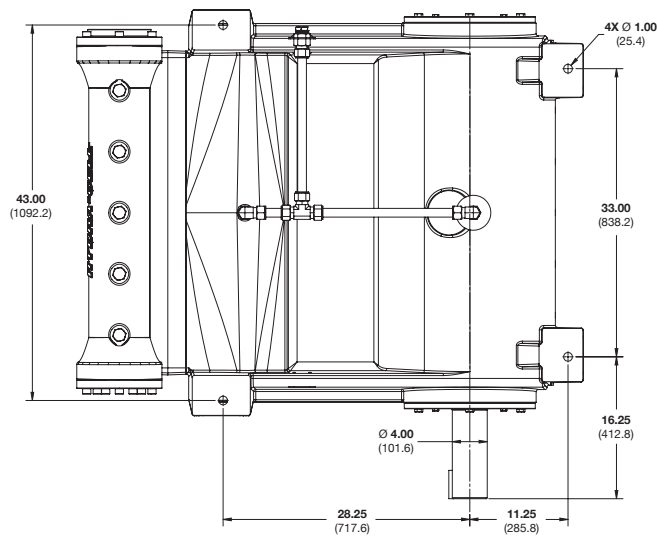

Note: Dimensions are for reference only. Contact factory for certified drawings.

Q330 Pro High Pressure | How to Order

Ordering Information

A complete Q330 Pro Series High Pressure Model Number contains 14 digits including 8 customer-specified design and materials options, for example: Q330KDDGHFETA.

1	2	3	4	5	6	7	8	9	10	11	12	13	14
Q	3	3	0			D					T		

High Pressure

Digit	Order Code	Description
1-4		Pump Configuration
	Q330	Shaft-driven
5		Performance
	P	Max. 118 gpm (446 l/min) 4047 BPD @ 4000 psi (276 bar)
	Q	Max. 104 gpm (393 l/min) 3567 BPD @ 4500 psi (310 bar)
6		Pump Head Version
	A	NPT Ports (Steel)
	C	Weld Neck (Steel)
	D	Weld Neck (316L Stainless Steel)
	R	ANSI Flange Ports (Steel)
	S	ANSI Flange Ports (316L Stainless Steel)
7		Pump Head Material
	D	Nickel Aluminum Bronze (NAB)
8		Diaphragm & O-ring Material
	G	FKM
	T	Buna-N
9		Valve Seat Material
	H	17-4 Stainless Steel
	N	Nitronic 50
	T	Hastelloy C
10		Valve Material
	F	17-4 Stainless Steel
	N	Nitronic 50
	T	Hastelloy C
11		Valve Springs
	E	Elgiloy
	T	Hastelloy C
12		Valve Spring Retainers
	T	Hastelloy C
13		Hydra-Oil
	A	10W30 standard-duty oil
	B	40-wt. oil
	H	15W50 high-temp severe-duty synthetic oil

Digit	Order Code	Description
14		Oil Level Monitor Cover
	C	Float switch, normally closed (recommended)
	O	Float switch, normally open
	Y	No switch, flat back cover



Partners in over 70 countries

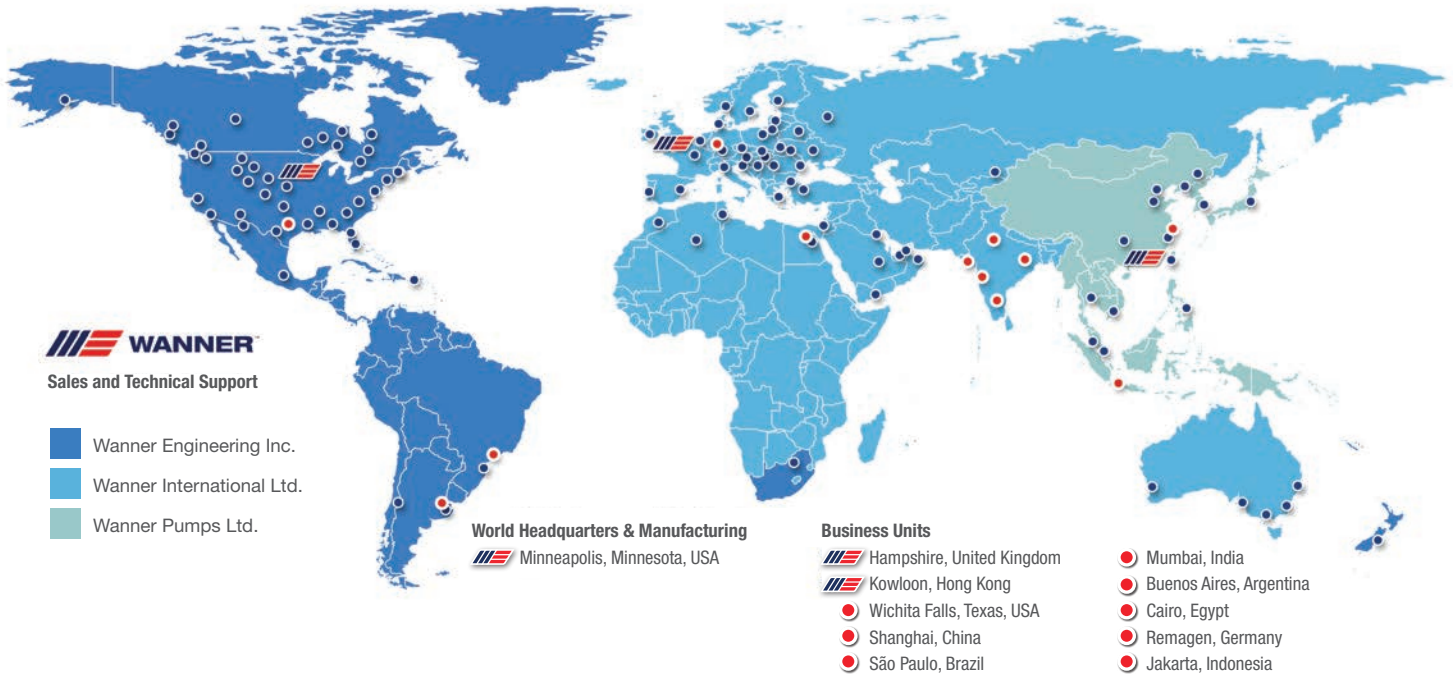

Wanner worldwide

GLOBAL SALES & TECHNICAL SUPPORT

WANNER ENGINEERING, INC.™

WORLD HEADQUARTERS & MANUFACTURING

Minneapolis, Minnesota USA
t: 612-332-5681
e: sales@wannereng.com
Hydra-Cell.com

REGIONAL OFFICE

Wichita Falls, Texas USA
t: 940-322-7111
e: sales@wannereng.com

LATIN AMERICAN OFFICE

São Paulo, Brazil
t: +55 (11) 99582-1969
e: mmagoni@wannereng.com
Hydra-Cell-Pumps.com.br

WANNER INTERNATIONAL, LTD.™

UNITED KINGDOM

8 & 9 Fleet Business Park
Sandy Lane • Church Crookham
Hampshire UK GU52 8BF
t: +44 (0) 1252 816847
e: support@wannerint.com
Hydra-Cell.co.uk

WANNER PUMPS, LTD.™

Kowloon, HONG KONG

t: +852 3428 6534
e: sales@wannerpumps.com
WannerPumps.com

Shanghai, CHINA
t: +86-21-6876 3700
e: sales@wannerpumps.com
WannerPumps.com

