

INSTALLATION & SERVICE

D03-991-2400A

Hydra-Cell[®]

INDUSTRIAL PUMPS

Models: D-03, G-03, G-13, M-03 and M-23
Kel-Cell and Standard Versions

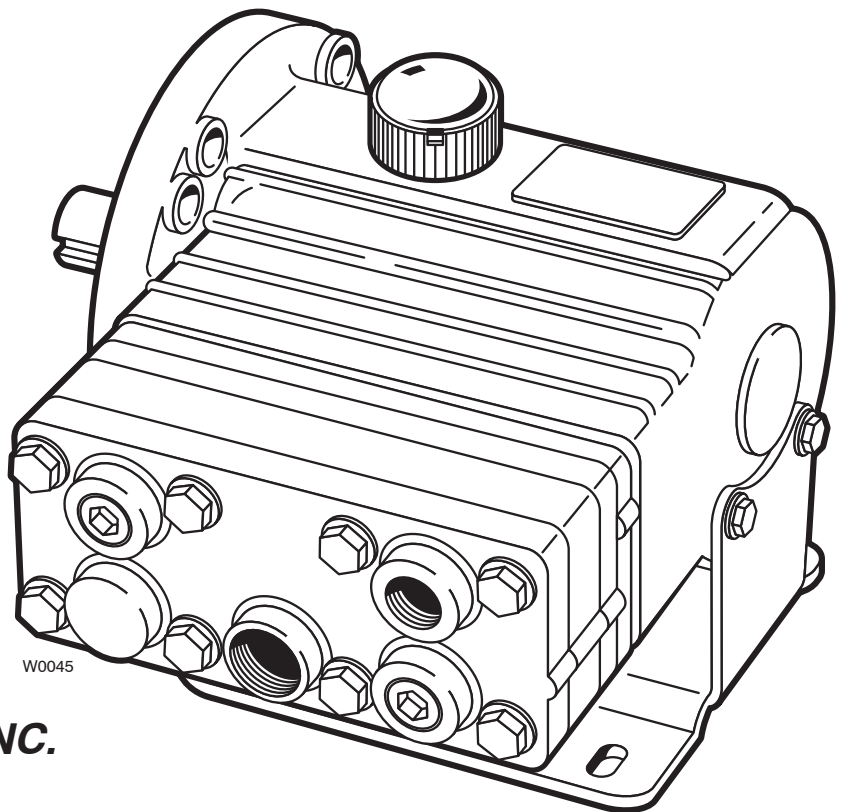

W0045



WANNER ENGINEERING, INC.

1204 Chestnut Avenue, Minneapolis, MN 55403

TEL: (612) 332-5681 FAX: (612) 332-6937

TOLL-FREE FAX [US only]: (800) 332-6812

www.hydra-cell.com

email: sales@wannereng.com

D/G-03 Contents

	Page
Specifications.....	2
Dimensions	4
Installation.....	7
Maintenance.....	10
Fluid End Service.....	11
Hydraulic End Service	15
Troubleshooting.....	18

Component Identification

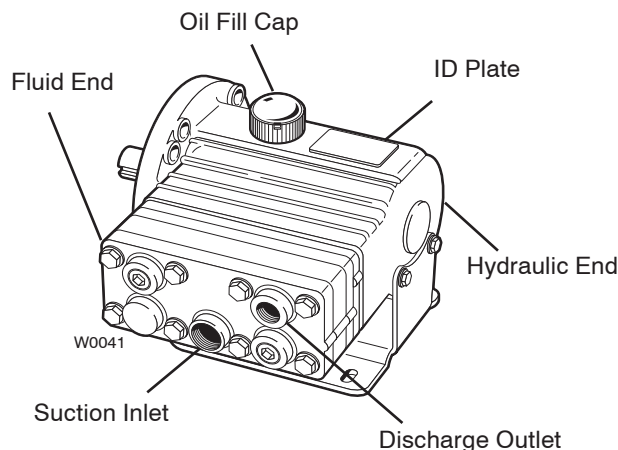

D/G-03 Specifications

Max Pressure

Metallic Heads:

D/G-03-X (including Kel-Cell)*: 1000 psi (70 bar);

D/G-03-E (Kel-Cell)*: 1000 psi (70 bar),
(non Kel-Cell): 1200 psi (83 bar)

D/G-03-S, B, G: 1200 psi (83 bar)

Non-Metallic Heads:

All models: 250 psi (17 bar)

Capacity@ Max Pressure

	rpm	gpm	l/min
D/G-03-X (including Kel-Cell)*	1750	3.0	11.3
D/G-03-E (including Kel-Cell)*	1750	2.2	8.3
D/G-03-S	1750	1.8	6.8
D/G-03-B	1750	1.1	4.2
D/G-03-G	1750	0.5	1.9

Delivery @ Max Pressure*

	revs/gal	revs/liter
D/G-03-X (including Kel-Cell)*	584	155
D/G-03-E (including Kel-Cell)*	795	204
D/G-03-S	972	258
D/G-03-B	1591	415
D/G-03-G	3500	906

Max Inlet Pressure 250 psi (17 bar)

Max Temperature

Metallic Heads: 250°F (121°C) – consult factory for temperatures above 160°F (71°C)

Non-Metallic Heads: 140°F (60°C)

Inlet Port

D-03, M-03, M-23: 1/2 inch NPT
G-03, G-13: 1/2 inch BSPT

Discharge Port

D-03, M-03, M-23: 3/8 inch NPT
G-03, G-13: 3/8 inch BSPT

* Kel-Cell available in X and E models only.

Shaft Diameter

D-03/G-03: 7/8 inch (22.22) shaft driven

M-03: 5/8 inch hollow (for NEMA 56C C-Face motor)

G-13: 24 mm hollow shaft (for IEC 90L, B5 Flange motor)

M-23: 20 mm hollow shaft (for use with Honda Engine)

Shaft Rotation

Bi-directional

Bearings

Ball bearings

Oil Capacity

1 US quarts (0.95 liters)

Weight

Metallic Heads: 28 lbs (12.7 kg)

Non-Metallic Heads: 19 lbs (8.6 kg)

Note:

Performance and specification ratings apply to all configurations unless specifically noted otherwise. Kel-Cell pumps available in D/G-03-X and D/G-03-E configurations only.

Calculating Required Horsepower (kW)‡

$$\frac{6 \times \text{rpm}}{63,000} + \frac{\text{gpm} \times \text{psi}}{1,460} = \text{electric motor HP}^*$$

$$\frac{6 \times \text{rpm}}{84,428} + \frac{\text{lpm} \times \text{bar}}{511} = \text{electric motor kW}^*$$

‡ rpm equals pump shaft rpm. HP/kW is required application power. Use caution when sizing motors with variable speed drives. Consult engine manufacturer for gasoline or diesel power requirements.

D/G-03 Specifications

Performance

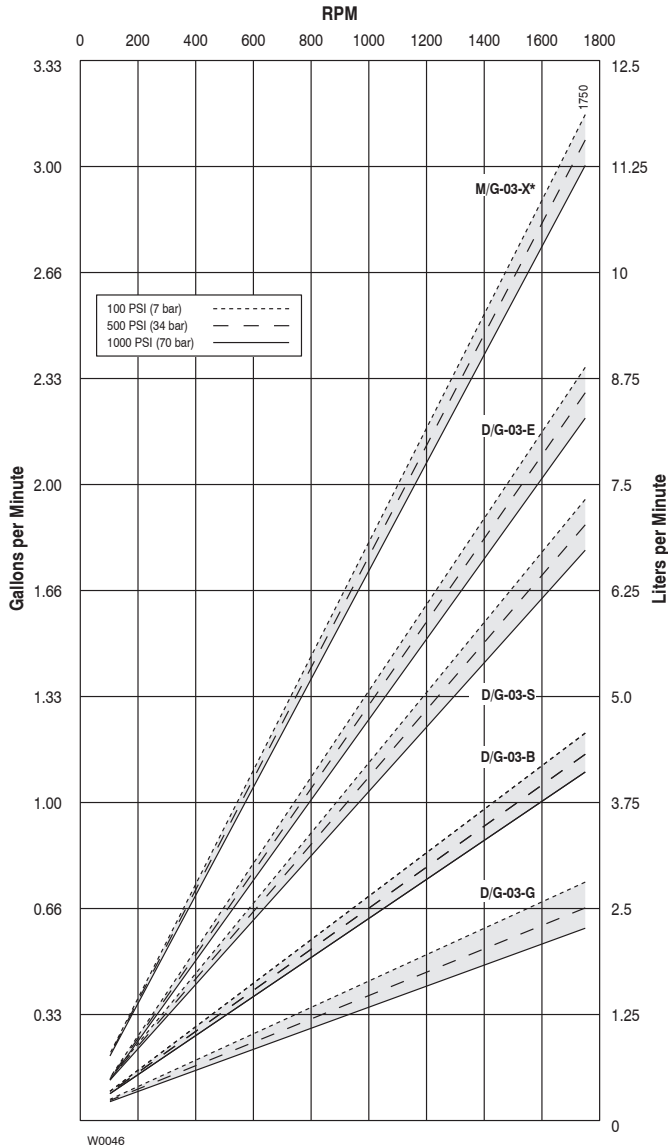

Net Positive Suction Head – NPSHr

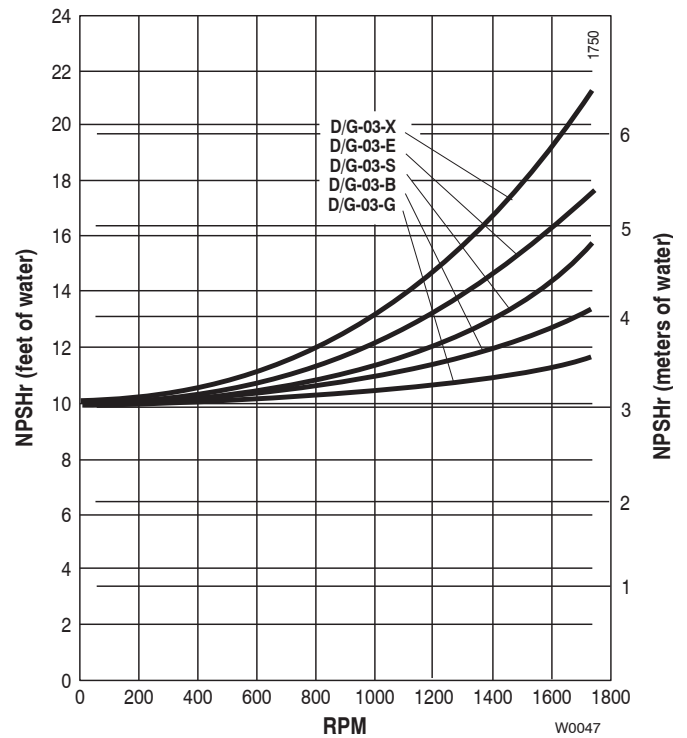

Dry Lift

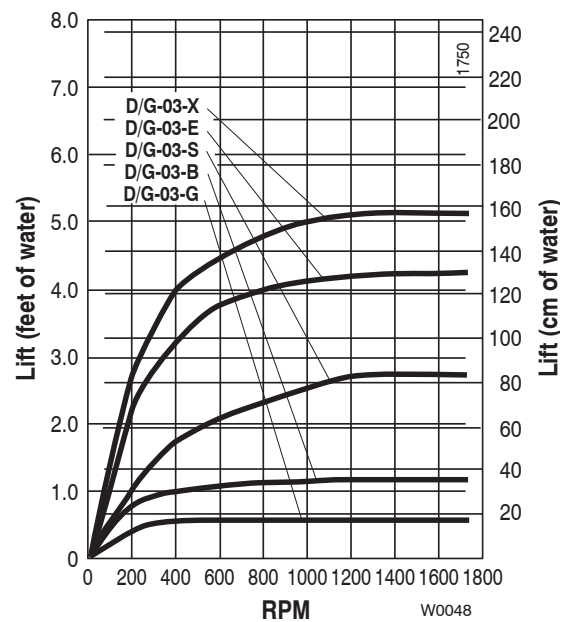

Note:

Performance and specification ratings apply to all configurations unless specifically noted otherwise. Kel-Cell flow will be about four percent less than that shown in the graph above.

D/G-03 Dimensions

M-03/G-13 Models with Metallic Pumping Head

Brass

316 Stainless Steel

Nickel Alloy (Hastelloy CW12MW)

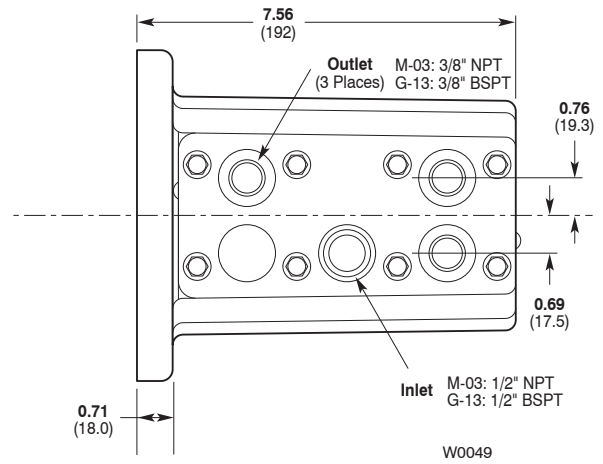
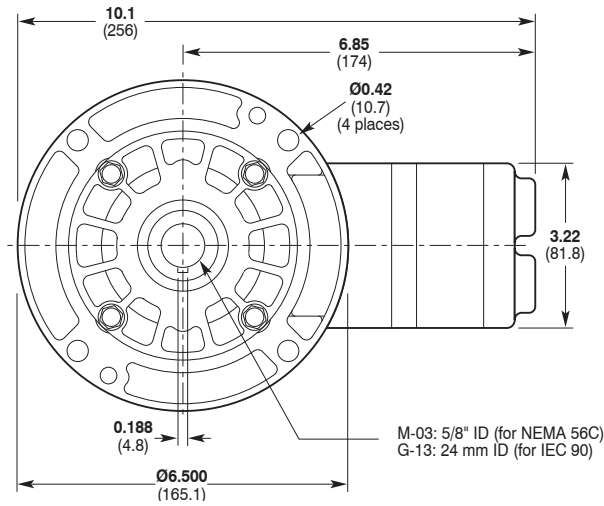

M-03/G-13 Models with Non-Metallic Pump Head

Kynar®

Polypropylene

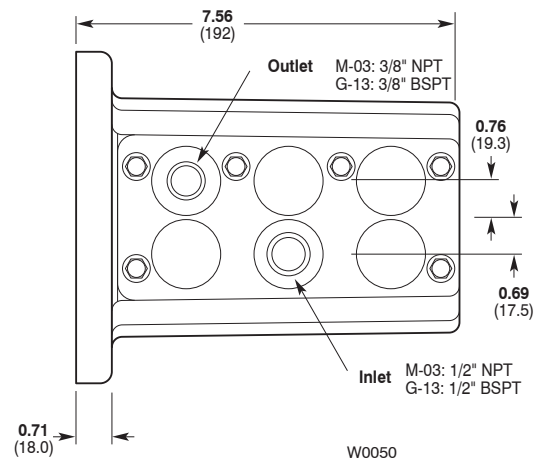
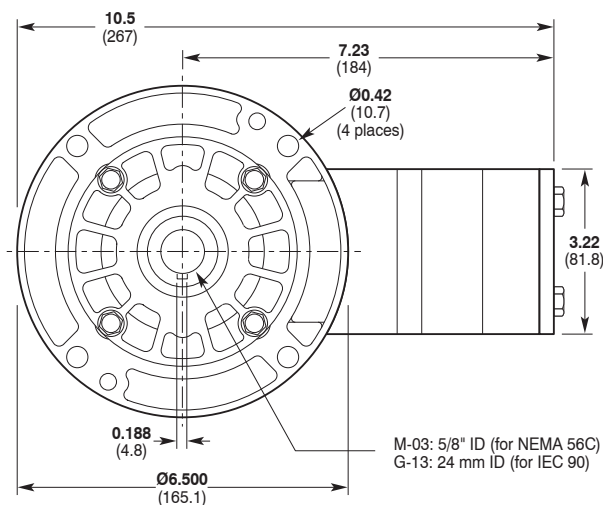

D/G-03 Dimensions

D-03/G-03 Models with Metallic Pumping Head

Brass

316 Stainless Steel

Nickel Alloy (Hastelloy CW12MW)

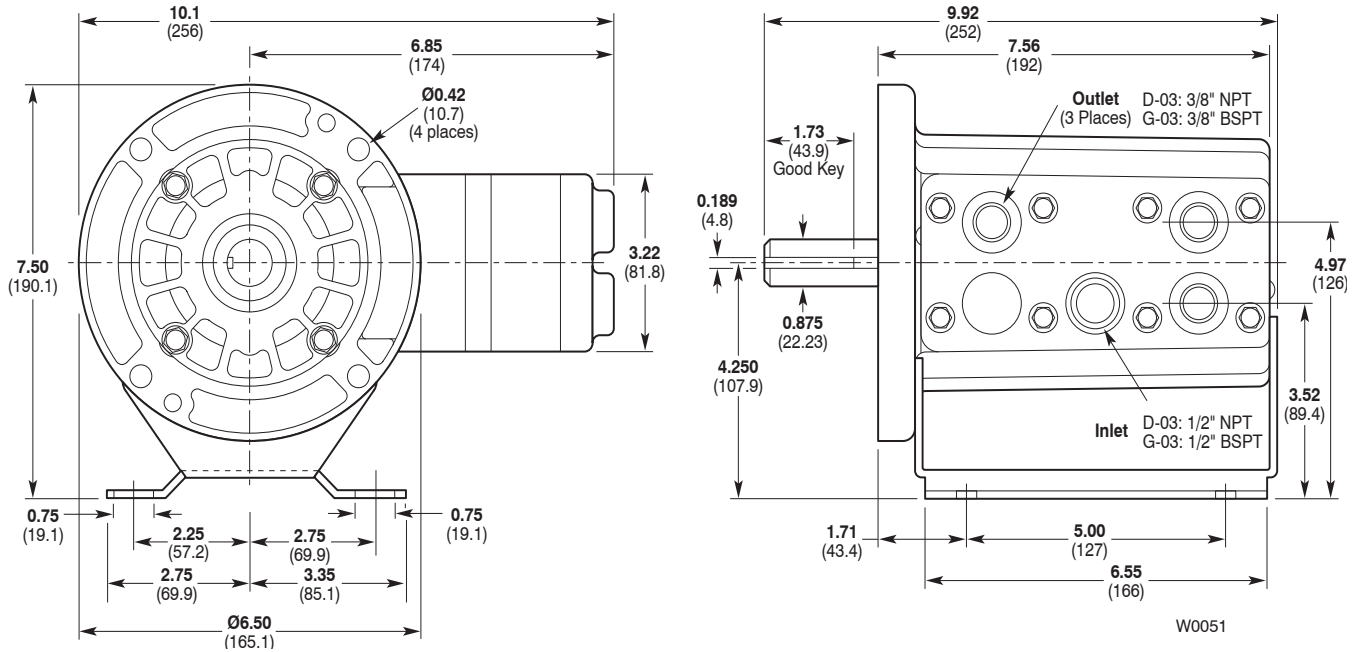

D-03/G-03 Models with Non-Metallic Pump Head

Kynar®

Polypropylene

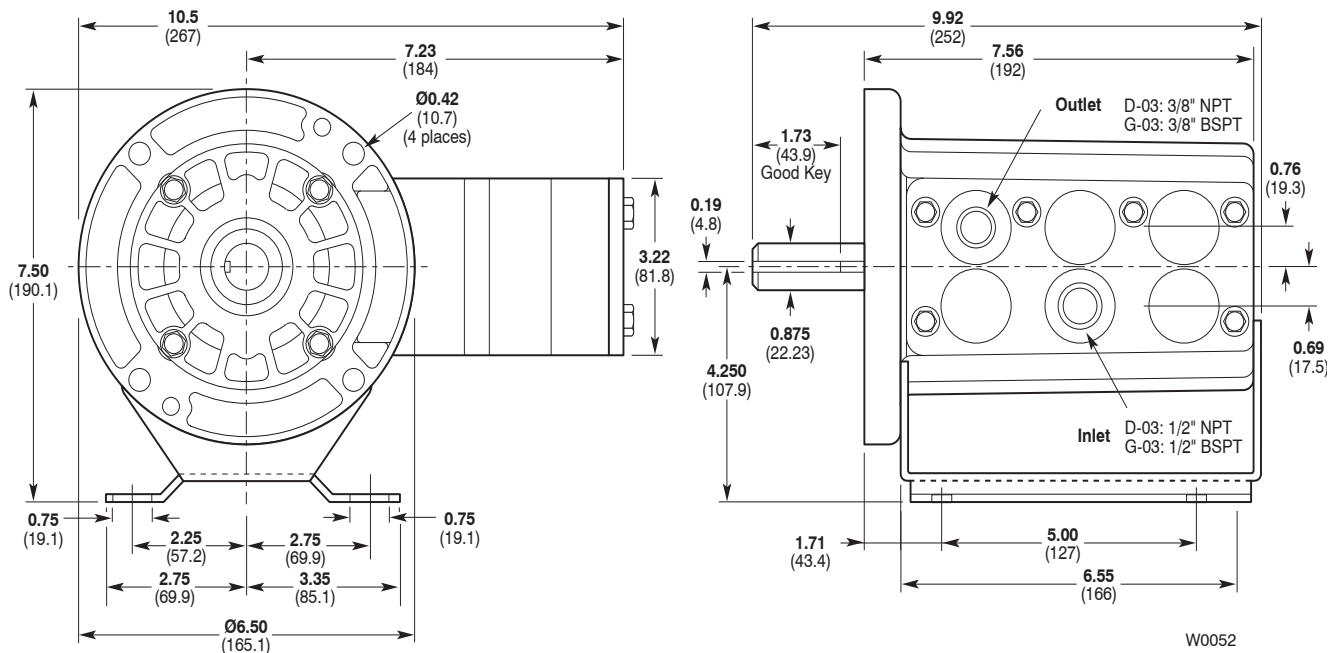

D/G-03 Dimensions

M-23 Models with Metallic Pumping Head

Brass

316 Stainless Steel

Nickel Alloy (Hastelloy CW12MW)

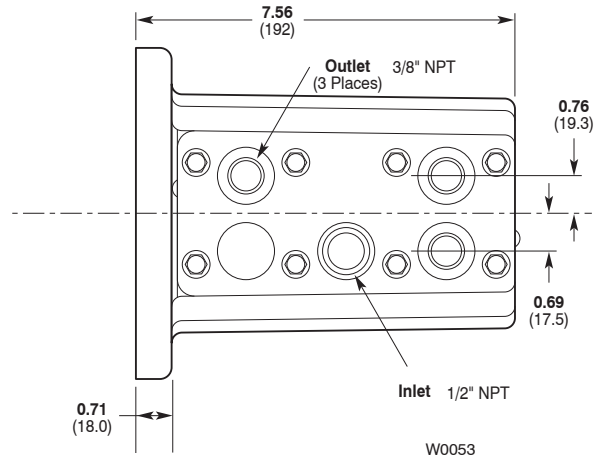
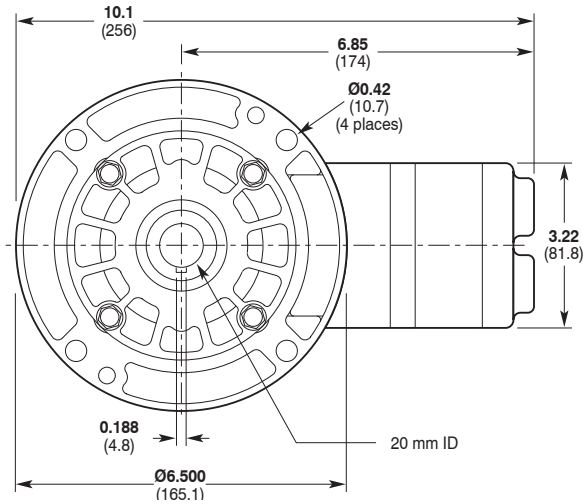

M-23 Models with Non-Metallic Pump Head

Kynar®

Polypropylene

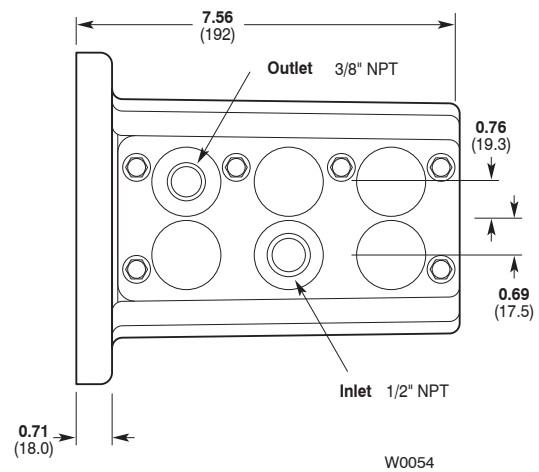
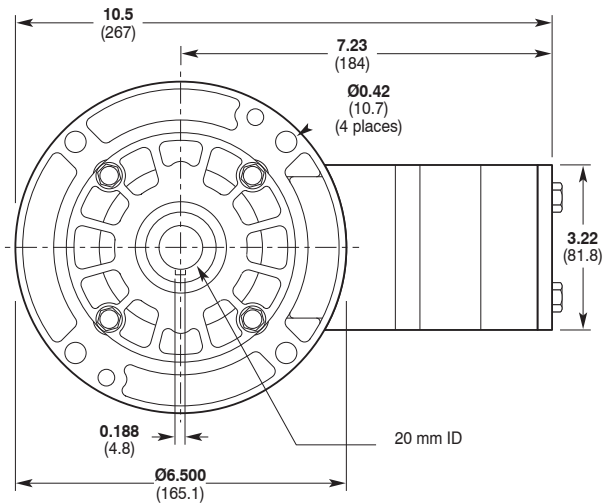

D/G-03 Installation

NOTE: The numbers in parentheses are the Reference Numbers on the illustrations in the Parts Manual.

Location

Locate the pump as close to the supply source as possible. Install it in a lighted clean space where it will be easy to inspect and maintain. Allow room for checking the oil level, changing the oil, and removing the pump head (manifold, valve plate and related items).

Mounting

The pump shaft can rotate in either direction. To prevent vibration, securely attach the pump (D-03, G-03) or motor (M-03, M-23, G-13) to a rigid base.

On a belt-drive system, align the sheaves accurately; poor alignment wastes horsepower and shortens the belt and bearing life. Make sure the belts are properly tightened, as specified by the belt manufacturer.

On a direct-drive system, align the shafts accurately. Unless otherwise specified by the coupling manufacturer, maximum parallel misalignment should not exceed .015" and angular misalignment should be held to 1 degree maximum. Careful alignment extends life of the coupling, pump, shafts, and support bearings. Consult coupling manufacturer for exact alignment tolerances.

On a close-coupled system, coat the motor shaft liberally with anti-seize.

Important Precautions

Adequate Fluid Supply. To avoid cavitation and premature pump failure, be sure that the pump will have an adequate fluid supply and that the inlet line will not be obstructed. See "Inlet Piping".

Positive Displacement. This is a positive-displacement pump. To avoid severe system damage if the discharge line ever becomes blocked, install a relief valve downstream from the pump. See "Discharge Piping".

Safety Guards. Install adequate safety guards over all pulleys, belts, and couplings. Follow all codes and regulations regarding installation and operation of the pumping system.

Shut-Off Valves. Never install shut-off valves between the pump and discharge pressure regulator, or in the regulator bypass line.

Freezing Conditions. Protect the pump from freezing. See also the Maintenance Section.

Consult the Factory for the following situations:

- Extreme temperature applications (above 160° F or below 40° F)
- Pressure feeding of pumps
- Viscous or abrasive fluid applications
- Chemical compatibility problems
- Hot ambient temperatures (above 110° F)
- Conditions where pump oil may exceed 200° F because of a combination of hot ambient temperatures, hot fluid temperature, and full horsepower load — an oil cooler may be required

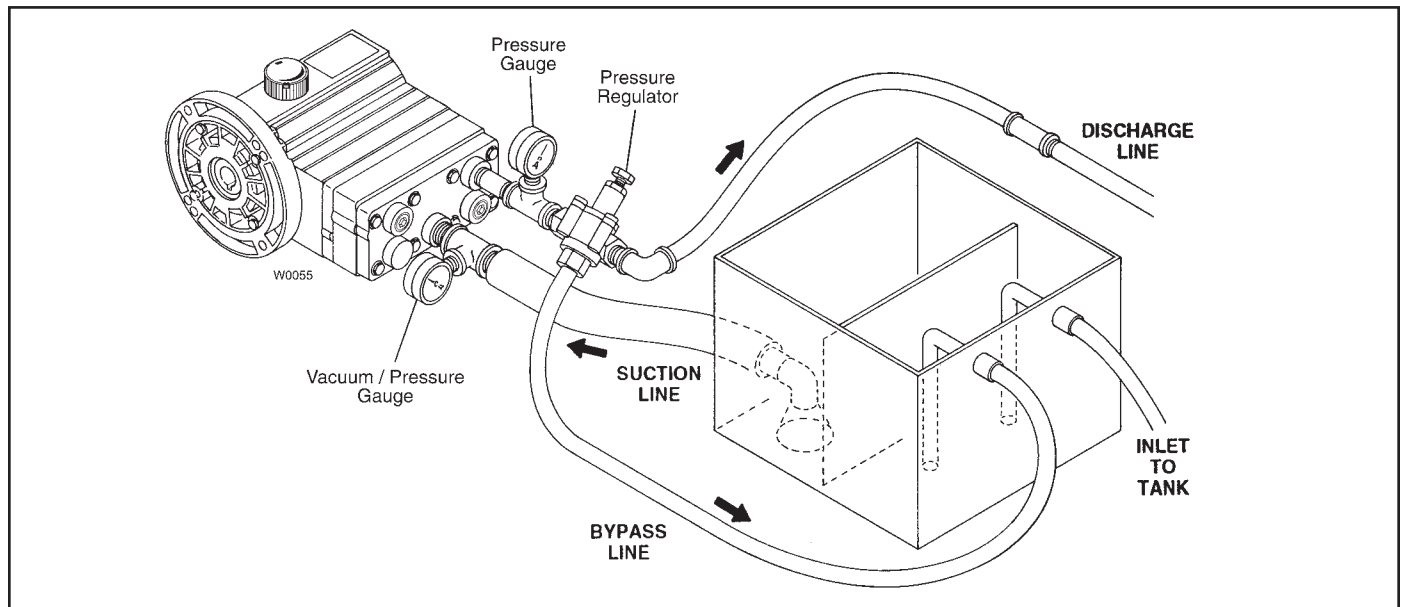

D/G-03 Installation

Inlet Piping (Suction Feed)

Caution: When pumping at temperatures above 160° F (71° C), use a pressure-feed system.

Install drain cocks at any low points of the suction line, to permit draining in freezing conditions.

Provide for permanent or temporary installation of a vacuum gauge to monitor the inlet suction. To maintain maximum flow, vacuum at the pump inlet should not exceed 7 in. Hg at 3 gpm and 70° F (180 mm Hg at 11.4 liters/min and 21° C). Do **not** supply more than one pump from the same inlet line. With PTFE diaphragms, the inlet must be flooded.

Supply Tank

Use a supply tank that is large enough to provide time for any trapped air in the fluid to escape. The tank size should be at least twice the maximum pump flow rate.

Isolate the pump and motor stand from the supply tank, and support them separately.

Install a separate inlet line from the supply tank to each pump.

Install the inlet and bypass lines so they empty into the supply tank below the lowest water level, on the opposite side of the baffle from the pump suction line.

If a line strainer is used in the system, install it in the inlet line to the supply tank.

To reduce aeration and turbulence, install a completely submerged baffle plate to separate the incoming and outgoing liquids.

Install a vortex breaker in the supply tank, over the outlet port to the pump.

Place a cover over the supply tank, to prevent foreign objects from falling into it.

Hose and Routing

Size the suction line at least one size larger than the pump inlet, and so that the velocity will not exceed 1-3 ft/sec (0.3 to 0.9 m/sec):

For pipe in inches: Velocity (ft/sec) = 0.408 x GPM/Pipe ID²

For pipe in mm: Velocity (m/sec) = 21.2 x LPM/Pipe ID²

Keep the suction line as short and direct as possible.

Use flexible hose and/or expansion joints to absorb vibration, expansion, or contraction.

If possible, keep the suction line level. Do not have any high points to collect vapor unless these high points are vented.

To reduce turbulence and resistance, do not use 90° elbows. If turns are necessary in the suction line, use 45° elbows or arrange sweeping curves in the flexible inlet hose.

If a block valve is used, be sure it is fully opened so that the flow to the pump is not restricted. The opening should be at least the same diameter as the inlet plumbing ID.

Do not use a line strainer or filter in the suction line unless regular maintenance is assured. If used, it should have a free-flow area of at least three times the free-flow area of the inlet.

Install piping supports where necessary to relieve strain on the inlet line and to minimize vibration.

Inlet Piping (Pressure Feed)

Provide for permanent or temporary installation of a vacuum/pressure gauge to monitor the inlet vacuum or pressure. Pressure at the pump inlet should not exceed 250 psi (17.3 bar); if it could get higher, install an inlet pressure regulator. Do **not** supply more than one pump from the same inlet line.

Inlet Calculations

Acceleration Head

Calculating the Acceleration Head

Use the following formula to calculate acceleration head losses. Subtract this figure from the NPSHa, and compare the result to the NPSHr of the Hydra-Cell pump.

$$H_a = (L \times V \times N \times C) \div (K \times G)$$

where:

H_a = Acceleration head (ft of liquid)

L = Actual length of suction line (ft) — not equivalent length

V = Velocity of liquid in suction line (ft/sec) [V = GPM x (0.408 ÷ pipe ID²)]

N = RPM of crank shaft

C = Constant determined by type of pump — use 0.066 for the M-03, D-03, M-23, G-03 and G-13 Hydra-Cell pumps

K = Constant to compensate for compressibility of the fluid — use: 1.4 for de-aerated or hot water; 1.5 for most liquids; 2.5 for hydrocarbons with high compressibility

G = Gravitational constant (32.2 ft/sec²)

Friction Losses

Calculating Friction Losses in Suction Piping

When following the above recommendations (under “inlet Piping”) for minimum hose/pipe I.D. and maximum length, frictional losses in the suction piping are negligible (i.e., H_f = 0) if you are pumping a water-like fluid.

When pumping more-viscous fluids such as lubricating oils, sealants, adhesives, syrups, varnishes, etc., frictional losses in the suction piping may become significant. As H_f increases, the available NPSH (NPSHa) will decrease, and cavitation will occur.

In general, frictional losses increase with increasing viscosity, increasing suction-line length, increasing pump flowrate, and decreasing suction-line diameter. Changes in suction-line diameter have the greatest impact on frictional losses: a 25% increase in suction-line diameter cuts losses by more than two times, and a 50% increase cuts losses by a factor of five times.

Consult the factory before pumping viscous fluids.

Minimizing Acceleration Head and Frictional Losses

To minimize the acceleration head and frictional losses:

- Keep inlet lines less than 3 ft (1 m) long
- Use at least 5/8 in. (16 mm) I.D. inlet hose
- Use soft hose (low-pressure hose, noncollapsing) for the inlet lines
- Minimize fittings (elbows, valves, tees, etc.)
- **Use a suction stabilizer on the inlet.**

D/G-03 Installation

Net Positive Suction Head

NPSHa must be equal to or greater than NPSHr. If not, the pressure in the pump inlet will be lower than the vapor pressure of the fluid— and cavitation will occur.

Calculating the NPSHa

Use the following formula to calculate the NPSHa:

$$\text{NPSHa} = P_t + H_z - H_f - H_a - P_{vp}$$

where:

P_t = Atmospheric pressure

H_z = Vertical distance from surface liquid to pump center line (if liquid is below pump center line, the H_z is negative)

H_f = Friction losses in suction piping

H_a = Acceleration head at pump suction

P_{vp} = Absolute vapor pressure of liquid at pumping temperature

NOTES:

- In good practice, NPSHa should be 2 ft greater than NPSHr
- All values must be expressed in feet of liquid

Atmospheric Pressure at Various Altitudes

Altitude (ft)	Pressure (ft of H ₂ O)	Altitude (ft)	Pressure (ft of H ₂ O)
0	33.9	1500	32.1
500	33.3	2000	31.5
1000	32.8	5000	28.2

Discharge Piping

Note: Consult the Factory before manifolding two or more pumps together.

Hose and Routing

Use the shortest, most-direct route for the discharge line.

Select pipe or hose with a **working pressure** rating of at least 1.5 times the maximum system pressure. EXAMPLE: Select a 1500 psi (103 bar) W.P. rated hose for systems to be operated at 1000 psi (69 bar) gauge pressure.

Use about 6 ft (1.8 m) of flexible hose between the pump and rigid piping to absorb vibration, expansion or contraction.

Support the pump and piping independently. Size the discharge line so that the velocity of the fluid will not exceed 7-10 ft/sec (2-3 m/sec):

$$\text{For pipe in inches: Velocity (ft/sec)} = 0.408 \times \text{GPM/Pipe ID}^2$$

$$\text{For pipe in mm: Velocity (m/sec)} = 21.2 \times \text{LPM/Pipe ID}^2$$

Pressure Regulation

Install a pressure regulator or unloader in the discharge line. Bypass pressure must not exceed the pressure limit of the pump.

Size the regulator so that, when fully open, it will be large enough to relieve the full capacity of the pump without over pressurizing the system.

Locate the regulator as close to the pump as possible and ahead of any other valves.

Adjust the pressure regulator valve to no more than 10% over the maximum working pressure of the system. Do not exceed the manufacturer's pressure rating for the pump or regulator.

Route the bypass line to the supply tank, or to the suction line as far as possible from the pump (to reduce the chance of turbulence).

If the pump will be operating for a long time with the discharge closed and fluid bypassing, install a thermal protector set to trip at 140° F in the bypass line (to prevent severe temperature buildup in the bypassed fluid).

CAUTION: Never install shutoff valves in the bypass line or between the pump and pressure regulator or relief valve.

Provide for permanent or temporary installation of a pressure gauge to monitor the discharge pressure at the pump.

For additional system protection, install a safety relief valve in the discharge line, downstream from the pressure regulator.

Before Initial Start-Up

Before you start the pump, be sure that:

- All shut-off valves are open, and the pump has an adequate supply of fluid.
- All connections are tight.
- The oil level is 3/4 in. (20 mm) from the top of the fill port
- The relief valve on the outlet of the pump is adjusted so the pump starts under minimum pressure.
- All pulleys and belts are properly aligned, and belts are tensioned according to specification.
- All pulleys and belts have adequate safety guards.

Initial Start-Up Procedure

1. Turn on power to the pump motor.
2. Check the inlet pressure or vacuum. To maintain maximum flow, inlet vacuum must not exceed 7 in. Hg at 70° F (180 mm Hg at 21° C). Inlet pressure must not exceed 250 psi (17.3 bar).
3. Listen for any erratic noise and look for unsteady flow.
4. If the system has an air lock and the pump fails to prime:
 - a. Turn off the power.
 - b. Open one outlet port.
 - c. Briefly restart the system and operate it until fluid comes out the outlet port.
 - d. Turn off the power and reinstall the outlet port plug.
5. Adjust the discharge pressure regulator to the desired operating and bypass pressures. Do not exceed the maximum pressure rating of the pump.
6. After the pressure regulator is adjusted, set the "pop-off" safety relief valve at 100 psi (6.9 bar) higher than the desired operating pressure.

D/G-03 Maintenance

NOTE: The numbers in parentheses are the Ref. Nos. on the illustrations in the Parts Manual.

Daily

Check the oil level and the condition of the oil. The oil level should be 3/4 in. (20 mm) from the top of the fill port.

Use the appropriate Wanner Hydra-Oil brand motor oil for the application (contact Wanner Engineering if in doubt).

Caution: If you are losing oil but don't see any external leakage, or if the oil becomes discolored and contaminated, one of the diaphragms (17) may be damaged. Refer to the Service Section. Do not operate the pump with a damaged diaphragm.

Caution: Do not leave contaminated oil in the pump housing or leave the housing empty. Remove contaminated oil as soon as discovered, and replace it with clean oil.

Periodically

Change the oil after the first 100 hours of operation, then change according to the guidelines below. When changing, remove the drain plug (60). Allow all oil and contaminant to drain out.

Hours Between Oil Changes @ Various Process Fluid Temperatures

Pressure	RPM	<90°F (32°C)	<139°F (60°C)	<180°F (82°C)
Metallic Pump Head				
<800 psi (55 bar)	<1200	8,000	5,000	3,000
	<1800	4,000	3,000	2,000
<1200 psi (83 bar)	<1200	4,000	3,000	2,000
	<1800	2,000	1,500	1,000
Non-Metallic Pump Head				
<250 psi (17 bar)	<1200	4,000	3,000	—
	<1800	2,000	1,500	—

NOTE: Minimum oil viscosity for proper hydraulic end lubrication is 16-20 cST (80-100 SSU).

CAUTION: Do not turn the drive shaft while the oil reservoir is empty.

Use the appropriate Hydra-Oil for the application (contact Wanner Engineering if in doubt).

CAUTION: If you are losing oil but don't see any external leakage, or if the oil becomes discolored and contaminated, the diaphragm (17) may be damaged. Refer to the Fluid-End Service Section. Do not operate the pump with a damaged diaphragm.

CAUTION: Do not leave contaminated oil in the pump housing or leave the housing empty. Remove contaminated oil as soon as discovered, and replace it with clean oil.

Check the inlet pressure or vacuum periodically with a gauge.

CAUTION: Protect the pump from freezing. Refer also to the "Shutdown Procedure".

Shutdown Procedure During Freezing Temperatures

Take all safety precautions to assure safe handling of the fluid being pumped. Provide adequate catch basins for fluid drainage and use appropriate plumbing from drain ports, etc. when flushing the pump and system with a compatible antifreeze.

1. Adjust the discharge pressure regulating valve so the pump runs under minimum pressure. Stop the pump.
2. Drain supply tank; open any draincocks in system piping and collect drainage; remove plugs from manifold and collect drainage.
3. Close draincocks in system piping and replace manifold plugs.
4. Fill supply tank with enough antifreeze to fill system piping and pump.
Note: disconnect the system return line from the supply tank and connect it to a separate reservoir.
5. Start the pump and allow it to run until the system is filled with antifreeze. Note: if the system has an air lock and the pump fails to prime, follow step 4 of the Initial Start-up Procedure to clear the air.
6. When mostly antifreeze is flowing from the system return line stop the pump. Connect the system return line back to the supply tank and circulate the antifreeze for a short period.
7. It is also good practice to change the oil in the Hydraulic End before storage for an extended period. This will remove any accumulated condensation and sediment from the oil reservoir. Drain and refill the Hydraulic End with the appropriate Hydra-Oil and operate the pump for a short period to assure smooth performance.

D/G-03 Fluid End Service

See Hydraulic End Service for pump housing details

Pump with Metallic Head (Kel-Cell version shown)

Pump with Non-Metallic Head (Kel-Cell version shown)

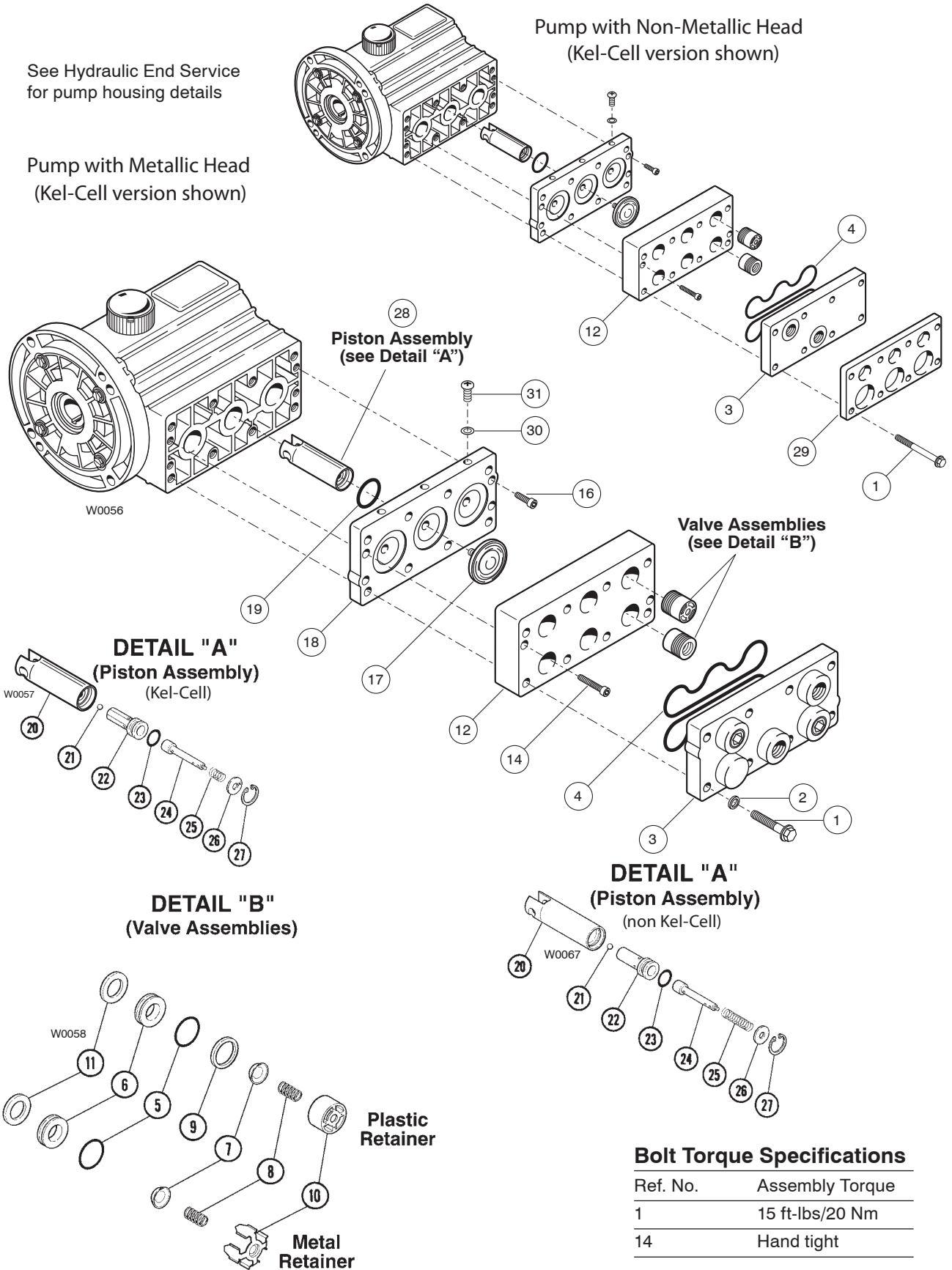

Bolt Torque Specifications

Ref. No.	Assembly Torque
1	15 ft-lbs/20 Nm
14	Hand tight

D/G-03 Fluid End Service (All versions)

This section explains how to disassemble and inspect all easily-serviceable parts of the pump. Repair procedures for the hydraulic end (oil reservoir) of the pump are included in a later section of the manual.

Note: The numbers in parentheses are the Ref. Nos. on the illustrations in the Parts Manual.

Caution: Do not disassemble the Hydraulic End unless you are a skilled mechanic. For assistance, contact Wanner Engineering (Tel 612-332-5681 or Fax 612-332-6937) or the distributor in your area.

Important: Fluid End Service is different for Kel-Cell and non Kel-Cell versions. Before performing Fluid End Service, determine if the pump is a Kel-Cell or non Kel-Cell version as follows:

Kel-Cell versions are indicated by a “K” in digit 5 of the pump model number.

Non Kel-Cell versions are indicated by an “A” or “D” in digit 5 of the pump model number.

1. Remove Manifold (3), Valve Plate (12) (All versions)

- Remove all eight bolts (1) around the manifold.
- Remove the manifold (3).
- Inspect the manifold for warping or wear around the inlet and outlet ports. If wear is excessive, replace the manifold.
To check if the manifold is warped, remove the O-rings (4) and place a straightedge across it. A warped manifold should be replaced.
- Remove the two socket-head capscrews (14).
- Inspect the valve plate in the same manner as the manifold.

2. Inspect Valves (5-11) (All versions)

The three inlet and three outlet valve assemblies are identical (but face in opposite directions). Inspect each valve as follows:

- Check the spring retainer (10), and replace if worn.
- Check the valve spring (8). If it is shorter than a new spring, replace it (don't just stretch the old spring).
- Check the valve poppet (7). If worn excessively, replace it.
- Remove the valve seat (6). A seat puller is included in the Wanner Tool Kit.
Inspect the valve seat for wear, and replace it if necessary. A new O-ring (5) should be installed.
- Check the dampening washer (11), and replace if worn.
- Reinstall the valve assemblies:
 - Clean the valve ports and shoulders with emery cloth, and lubricate them with lubricating gel or petroleum jelly.
 - Install the O-ring (5) on the valve seat (6).
 - Inlet (3 lower valves in the illustration below).** Insert the spring retainer (10) into the valve plate, then insert the spring, valve, tetra seal, valve seat with O-ring, and dampening washer (8,7,9,6,11). A flat O-ring [tetra seal] (5) goes between the plastic spring retainer and seat.
 - Outlet (3 upper valves in the illustration).** Install the 3 outlet valve assembly components in reverse order as inlet valves.

For Kel-Cell versions continue with Step 3 on page 13

For non Kel-Cell versions continue with Step 3 on page 14.

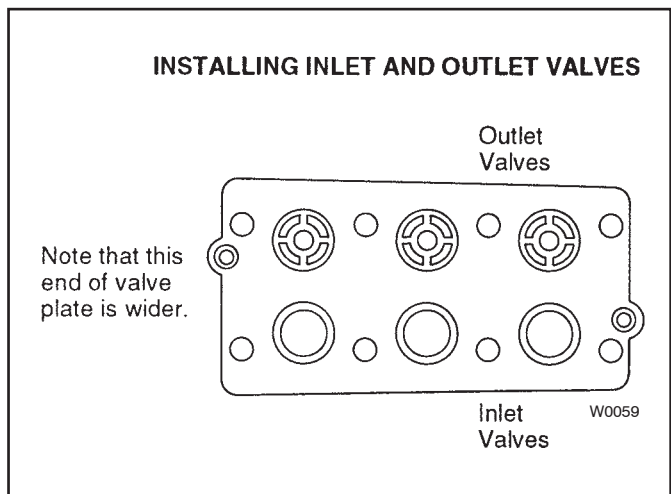

D/G-03 Fluid End Service (Kel-Cell only)

3. Inspect and Replace Diaphragms (17) (Kel-Cell only)

- a. Lift a diaphragm by one edge, and turn the pump shaft until the diaphragm moves up to “top dead center”. This will expose machined cross holes in the plunger shaft behind the diaphragm.

Note: If the pump has a hollow shaft, use the shaft rotator from the Wanner Tool Kit to turn the shaft.

- b. Remove the three flat-head screws (31) and O-rings (30) from the edge access holes in the diaphragm plate (18). Insert a 3/32” hex wrench (A03-163-2200) into one of the holes in the diaphragm plate (18). Turn and pull the diaphragm (17) until the front cross hole in the valve plunger spool (24) lines up and allows the hex wrench to pass through. (Don’t remove the hex wrench until the new diaphragm is installed in step “g” below.)
- c. Unscrew the diaphragm. Use a 5/16 in. (8 mm) open-end wrench, and turn counterclockwise.
- d. Inspect the diaphragm carefully. A ruptured diaphragm generally indicates a pumping system problem, and replacing only the diaphragm will not solve the larger problem. Inspect the diaphragm for the following:
 - **Small puncture.** Usually caused by a sharp foreign object in the fluid, or by an ice particle.
 - **Diaphragm pulled away** from the sides. Usually cause by fluid being frozen in the pump, or by over pressurization of the pump.
 - **Diaphragm becoming stiff** and losing flexibility. Usually caused by pumping a fluid that is incompatible with the diaphragm material.
 - **Diaphragm edge chewed away.** Usually caused by over pressurizing the system.

Caution: If a diaphragm has ruptured and foreign material or water has entered the oil reservoir, do not operate the pump. Check all diaphragms, then flush the reservoir completely (as outlined below) and refill it with fresh oil. Never let the pump stand with foreign material or water in the reservoir, or with the reservoir empty.

- e. Clean away any spilled oil. Apply Loctite No. 242 Threadlocker to the screw of the new diaphragm (or the old one, as appropriate).
- f. Install the diaphragm and tighten to 10 in-lbs (110 N-cm).
- g. Repeat the above inspection procedure (and replacement, if necessary) with the other two diaphragms.

4. Flush Contaminant from Hydraulic End (Kel-Cell only)

(Only if a diaphragm has ruptured)

- a. With the valve plate and manifold still removed (see above), remove the oil drain cap (60) and allow all oil and contaminant to drain out.

Caution: If you have EPDM diaphragms, or if food grade oil is in the reservoir, flush with the same lubricant that is in the reservoir. Pumps with EPDM diaphragms have an “E” as the 7th digit of the Model No.

- b. Fill the reservoir with fresh oil, manually turn the pump shaft to circulate the oil, and drain once again.
- c. Refill the reservoir. If the oil appears milky, there is still contaminant in the reservoir. Repeat the flushing procedure until the oil appears clean.

5. Reinstall Valve Plate (12), Manifold (3) (Kel-Cell only)

- a. Reinstall the valve plate (12), with the valve assemblies installed as outlined above, onto the diaphragm plate (18).
- b. Reinstall the O-rings (4) on the rear side of the manifold. Use petroleum jelly or lubricating gel to hold them in place.
- c. Reinstall the manifold onto the valve plate.
- d. Insert all bolts (1), with washers (2), around the edge of the manifold, and alternately tighten opposite bolts until all are secure. Torque to 15 ft-lbs (20 N-m).
- e. Recheck all bolts for tightness.

6. Prime the Hydraulic Cells (Kel-Cell only)

- a. With the pump **horizontal**, fill the reservoir with the appropriate Hydra oil for the application.
- b. All air in the oil within the hydraulic cell (behind the diaphragms) must be forced out by turning the shaft (and thus pumping the piston). A shaft rotator is included in the Wanner Tool Kit.

Turn or jog the shaft until a **bubble-free** flow of oil comes out of each access hole in the diaphragm plate (18). Watch the oil level in the reservoir; if it gets too low during priming, air will be drawn into the pistons (inside the hydraulic end). This will cause the pump to run rough, and you will have to start over again with priming the hydraulic cells.

Reinstall the flat-head screw (31) and O-ring (30) for each access hole as they are primed.

D/G-03 Fluid End Service (non Kel-Cell only)

3. Inspect and Replace Diaphragms (17) (non Kel-Cell)

- a. Lift a diaphragm by one edge, and turn the pump shaft until the diaphragm moves up to “top dead center”. This will expose machined cross holes in the plunger shaft behind the diaphragm.

Note: If the pump has a hollow shaft, use the shaft rotator from the Wanner Tool Kit.

- b. Insert a 3/32 in. hex wrench through one of the machined cross holes, to hold the diaphragm up. The proper size tool is included in the Wanner Tool Kit. (Don't remove the tool until the new diaphragm is installed in step “g” below.)
- c. Unscrew the diaphragm. Use a 5/16 in. (8 mm) open-end wrench, and turn counterclockwise.
- d. Inspect the diaphragm carefully. A ruptured diaphragm generally indicates a pumping system problem, and replacing only the diaphragm will not solve the larger problem. Inspect the diaphragm for the following:

- **Small puncture.** Usually caused by a sharp foreign object in the fluid, or by an ice particle.

- **Diaphragm pulled away** from the sides. Usually cause by fluid being frozen in the pump, or by overpressurization of the pump.

- **Diaphragm becoming stiff** and losing flexibility. Usually caused by pumping a fluid that is incompatible with the diaphragm material.

- **Diaphragm edge chewed away.** Usually caused by over pressurizing the system.

Caution: If a diaphragm has ruptured and foreign material or water has entered the oil reservoir, do not operate the pump. Check all diaphragms, then flush the reservoir completely (as outlined below) and refill it with fresh oil. Never let the pump stand with foreign material or water in the reservoir, or with the reservoir empty.

- e. Clean away any spilled oil. Apply Loctite No. 242 Threadlocker to the screw of the new diaphragm (or the old one, as appropriate).
- f. Install the diaphragm and tighten to 10 in.-lbs (110 N-cm).
- g. Repeat the above inspection procedure (and replacement, if necessary) with the other two diaphragms.

4. Flush Contaminant from Hydraulic End (non Kel-Cell)

(Only if a diaphragm has ruptured)

- a. With the valve plate and manifold still removed (see above), remove the oil drain cap (60) and allow all oil and contaminant to drain out.

Caution: If you have EPDM diaphragms, or if food grade oil is in the reservoir, flush with the same lubricant that is in the reservoir. Pumps with EPDM diaphragms have an “E” as the 7th digit of the Model No.

- b. Fill the reservoir with fresh oil, manually turn the pump shaft to circulate the oil, and drain once again.
- c. Refill the reservoir. If the oil appears milky, there is still contaminant in the reservoir. Repeat the flushing procedure until the oil appears clean.

5. Prime the Hydraulic Cells (non Kel-Cell)

- a. With the pump **horizontal**, fill the reservoir with the appropriate Hydra oil for the application.
- b. All air in the oil within the hydraulic cell (behind the diaphragms) must be forced out by turning the shaft (and thus pumping the piston). A shaft rotator is included in the Wanner Tool Kit.

Turn the shaft until a **bubble-free** flow of oil comes from behind all the diaphragms. Watch the oil level in the reservoir; if it gets too low during priming, air will be drawn into the pistons (inside the hydraulic end). This will cause the pump to run rough, and you will have to start over again with priming the hydraulic cells.

6. Reinstall Valve Plate (12), Manifold (3) (non Kel-Cell)

- a. Reinstall the valve plate (12), with the valve assemblies installed as outlined above, onto the diaphragm plate (18).
- b. Reinstall the O-rings (4) on the rear side of the manifold. Use petroleum jelly or lubricating gel to hold them in place.
- c. Reinstall the manifold onto the valve plate.
- d. Insert all bolts (1), with washers (2), around the edge of the manifold, and alternately tighten opposite bolts until all are secure. Torque to 15 ft-lbs (20 N-m).
- e. Recheck all bolts for tightness.

D/G-03 Hydraulic End Service

G-13 Pump Housing

M-23 Pump Housing

M-23 Only

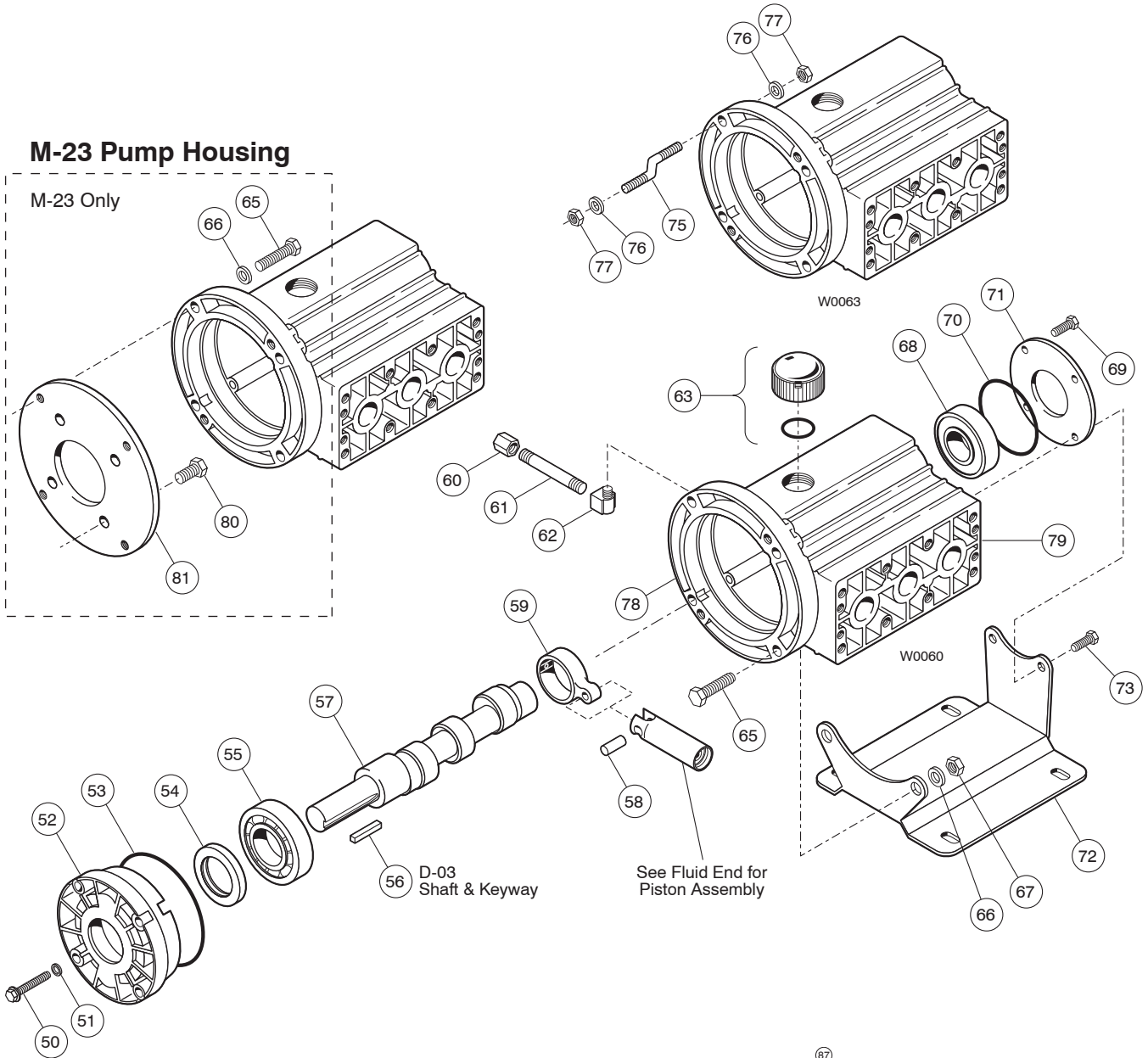

D/G-03 Pump/ Motor Adapter

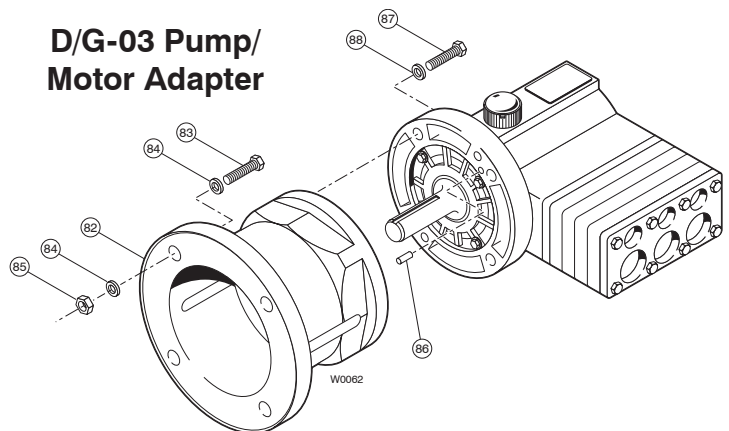

D/G-03 Hydraulic End Service

Note: The numbers in parentheses are the Ref. Nos. on the illustrations in the Parts Manual.

This section explains how to disassemble and inspect the hydraulic end (oil reservoir) of the pump.

Caution: Do not disassemble the hydraulic end unless you are a skilled mechanic. For assistance, contact Wanner Engineering (Tel 612-332-5681 or Fax 612-332-6937) or the distributor in your area.

Depending on the repair you are attempting, you may or may not have to remove the motor from a direct-drive pump/motor unit.

Internal piston components (21 - 27) can be serviced without removing the motor or crankshaft. The motor and crankshaft must be removed to service the connecting rod (59), piston housing (20), crankshaft (57), front bearing (68), back bearing (55), or seal (54).

To Service Pistons Without Removing Motor or Crankshaft

1. Disassemble Pistons

With the manifold, valve plate, diaphragm plate, and diaphragm removed, and the oil drained from the pump (see the Fluid End Service Section):

- Remove the snap ring (27) from one of the pistons, using a standard snap-ring pliers.
- Pull out the valve plunger (24). This also removes the washer (26) and spring (25).
- Insert a hook through the center hole of the valve cylinder (22), and pull the cylinder out of the piston. Be careful not to damage the piston.
- Inspect all parts, and replace the O-ring and any other parts that are worn or may be damaged.
- Repeat steps "a" through "d" for the remaining pistons.

2. Reassemble Pistons

- Tip the pump so the pistons are vertical.
- Drop a ball (21) into the opening in the bottom of the piston.
- Insert a valve plunger (24) into a valve cylinder (22). Slide a spring (25) over the plunger, inside the valve cylinder.
- Slide the assembled valve cylinder, plunger, and spring (22 - 25) into the piston (20).
- Insert a washer (26) over the plunger.
- Insert a snap ring (27) into the piston. Use the snap-ring pliers.
- Repeat the above procedure for the other two pistons.

To Remove Motor from Direct-Coupled Unit

1. Disassemble Motor from Pump

- M-03.** Remove the four bolts (65) and washers (66) that secure the pump and motor together.
M-23. Remove the four bolts (65) and washers (66) that secure the pump and adapter plate (81) together.
G-13. Remove the four nuts (77) and washers (76) from the motor side of the offset stud (75).
- M-03, M-23.** Install two of the bolts into the threaded holes in the rear of the pump housing.
G-13. Install two M10 x 1.5 x 40 mm (65) or longer bolts into the threaded holes in the rear flange of the pump housing.
- Alternately turn the bolts clockwise until the pump and motor separate.

2. Reassemble Motor to Pump

- Thoroughly clean the motor shaft and the hollow pump shaft. Remove the tape from the key and keyway.
- Apply a **liberal** amount of Loctite® Nickel Anti-Seize No. 77164 to the pump shaft.
- Install the shaft key (56) into the keyway.
- Slide the motor shaft into the hollow pump shaft.
Caution: When assembling this pump to the direct-coupled motor, be careful that the shaft key remains in the motor shaft keyway and does not ride up the keyway and contact the shaft seals (which would cause premature seal failure). Incorrect key placement could also cause the hollow pump shaft to fail.
Use a screwdriver to move the shaft key back in the motor shaft keyway as the motor and pump are drawn together.
- M-03, M-23.** Reinstall the four bolts (65) and washers (66).
G-13. Reinstall the four washers (76) and nuts (77).

D/G-03 Hydraulic End Service

To Service the Remainder of the Hydraulic End

1. Remove Pump Housing

- a. Remove the manifold, valve plate, and diaphragms, as outlined in the Fluid End Service Section.
- b. Drain the oil from the pump housing by removing the drain plug (60).
- c. Stand the pump on end, with the drive shaft up.
- d. Remove the bolts (50) that secure the back cover (52) to the housing (78). Use a 3/8 in. socket wrench (10-mm on M-03/G-03 and G-13). Save the O-rings (51).
- e. Remove the cover and the cover O-ring (53).
- f. Remove the crankshaft (57) by pulling it through the connecting rods (59).

2. Remove and Replace Pistons

To remove the pistons (20), first remove the connecting rod (59) and pin (58) by pressing the pin through the connecting rod.

Reverse the process to reinstall the pistons.

Refer to Steps 5 and 6 below to replace the diaphragm and reassemble the pump.

3. Replace Shaft Seal

Note: Inspect the shaft seal (54) before continuing. If it looks damaged in any way, replace it.

- a. Press the back bearing (55) and seal (54) out of the back cover (52). Discard the seal.
- b. Apply a coating of Loctite® High-Performance Pipe Sealant with PTFE, or a comparable product, to the outer surface of a new seal and the inside surface of the opening in the back cover (52) where the seal will rest.
- c. Press the new seal into the back cover.
- d. Inspect the bearing (55). If pitted or damaged, replace it.
- e. Apply a coating of Loctite Rc/609 Retaining Compound or comparable product to the outer surface of the bearing. Press the bearing into the back cover until it rests on the shoulder. The shield on the bearing must face away from the back cover.

4. Reassemble Housing and Back Cover

- a. Stand the pump on end.
- b. With the pistons and connecting rods in place, reinstall the crankshaft by threading it through the connecting rods.
- c. Reinstall the back cover (52), cover O-ring (53), and bolts (with their O-rings).

5. Reassemble Pump

Reassemble the pump as outlined in the Fluid-End Service Section.

D/G-03 Troubleshooting

Cavitation

- Inadequate fluid supply because:
 - Inlet line collapsed or clogged
 - Clogged line strainer
 - Inlet line too small or too long
 - Air leak in inlet line
 - Worn or damaged inlet hose
 - Suction line too long
 - Too many valves and elbows in inlet line
- Fluid too hot for inlet suction piping system.
- Air entrained in fluid piping system.
- Aeration and turbulence in supply tank.
- Inlet vacuum too high (refer to “Inlet Calculations”, page 3).

Symptoms of Cavitation

- Excessive pump valve noise
- Premature failure of spring or retainer
- Volume or pressure drop
- Rough-running pump
- Premature failure of diaphragms

Drop in Volume or Pressure

A drop in volume or pressure can be caused by one or more of the following:

- Air leak in suction piping
- Clogged suction line or suction strainer
- Suction line inlet above fluid level in tank
- Inadequate fluid supply
- Pump not operating at proper RPM
- Relief valve bypassing fluid
- Worn pump valve parts
- Foreign material in inlet or outlet valves
- Loss of oil prime in cells because of low oil level
- Ruptured diaphragm
- Cavitation
- Warped manifold from over pressurized system
- O-rings forced out of their grooves from over pressurization
- Air leak in suction line strainer or gasket
- Cracked suction hose.
- Empty supply tank
- Excessive aeration and turbulence in supply tank
- Cavitation
- Abrasives in the fluid
- Valve incompatible with corrosives in the fluid
- Pump running too fast
- Worn and slipping drive belt(s)
- Worn spray nozzle(s)

Pump Runs Rough

- Worn pump valves
- Air lock in outlet system
- Oil level low
- Wrong weight of oil for cold operating temperatures (change to lighter weight)
- Cavitation
- Air in suction line
- Restriction in inlet/suction line
- Hydraulic cells not primed after changing diaphragm
- Foreign material in inlet or outlet valve
- Damaged diaphragm
- Fatigued or broken valve spring

Premature Failure of Diaphragm

- Frozen pump
- Puncture by a foreign object
- Elastomer incompatible with fluid being pumped
- Pump running too fast
- Excess pressure
- Cavitation

Water (or Process Fluid) in Oil Reservoir

- Condensation
- Ruptured diaphragm
- Hydraulic cell not properly primed after diaphragm replacement
- Frozen pump

Strong Water (or Process Fluid) Pulsations

NOTE: Small pulsations are normal in single-acting pumps with multiple pumping chambers.

- Foreign object lodged in pump valve
- Loss of prime in hydraulic cell because of low oil level
- Air in suction line
- Valve spring (8) broken
- Cavitation
- Aeration or turbulence in supply tank

D/G-03 Troubleshooting

Valve Wear

- Normal wear from high-speed operation
- Cavitation
- Abrasives in the fluid
- Valve incompatible with corrosives in the fluid
- Pump running too fast

Loss of Oil

- External seepage
- Rupture of diaphragm
- Frozen pump
- Worn shaft seal
- Oil drain piping or fill cap loose.
- Valve plate and manifold bolts loose
- Pump housing porosity

Premature Failure of Valve Spring or Retainer

- Cavitation
- Foreign object in the pump
- Pump running too fast
- Spring/retainer material incompatible with fluid being pumped
- Excessive inlet pressure.

Limited Warranty

Wanner Engineering, Inc. extends to the original purchaser of equipment manufactured by it and bearing its name, a limited one-year warranty from the date of purchase against defects in material or workmanship, provided that the equipment is installed and operated in accordance with the recommendations and instructions of Wanner Engineering, Inc. Wanner Engineering, Inc. will repair or replace, at its option, defective parts without charge if such parts are returned with transportation charges prepaid to Wanner Engineering, Inc., 1204 Chestnut Avenue, Minneapolis, Minnesota 55403.

This warranty does not cover:

1. The electric motors (if any), which are covered by the separate warranties of the manufacturers of these components.
2. Normal wear and/or damage caused by or related to abrasion, corrosion, abuse, negligence, accident, faulty installation or tampering in a manner which impairs normal operation.
3. Transportation costs.

This limited warranty is exclusive, and is in lieu of any other warranties (express or implied) including warranty of merchantability or warranty of fitness for a particular purpose and of any non contractual liabilities including product liabilities based on negligence or strict liability. Every form of liability for direct, special, incidental or consequential damages or loss is expressly excluded and denied.



WANNER ENGINEERING, INC.

1204 Chestnut Avenue, Minneapolis, MN 55403
TEL: (612) 332-5681 FAX: (612) 332-6937
TOLL-FREE FAX [US only]: (800) 332-6812

www.hydra-cell.com
email: sales@wannereng.com