

# Hydra-Cell®

## Seal-less Pumps

**Versatile, Reliable Pumps for a Wide Range of Applications**



### G20 Series

- Pumps the full spectrum of low-to-high viscosity fluids.
- Features a seal-less design and horizontal disk check valves that enable the pump to handle abrasives and particulates that might damage or destroy other types of pumps.
- Simple, compact design reduces initial investment and lowers maintenance costs.
- Operational efficiencies reduce energy costs.
- Tolerates non-ideal operating conditions.
- Minimizes maintenance and downtime because there are no mechanical or dynamic seals, packing, or cups to leak, wear, or replace.

# G20 Series

---

Maximum Flow Rate: 1.0 gpm (3.8 l/min)

Maximum Pressure: 1500 psi (103 bar) for Metallic Pump Heads  
350 psi (24 bar) for Non-metallic Pump Heads

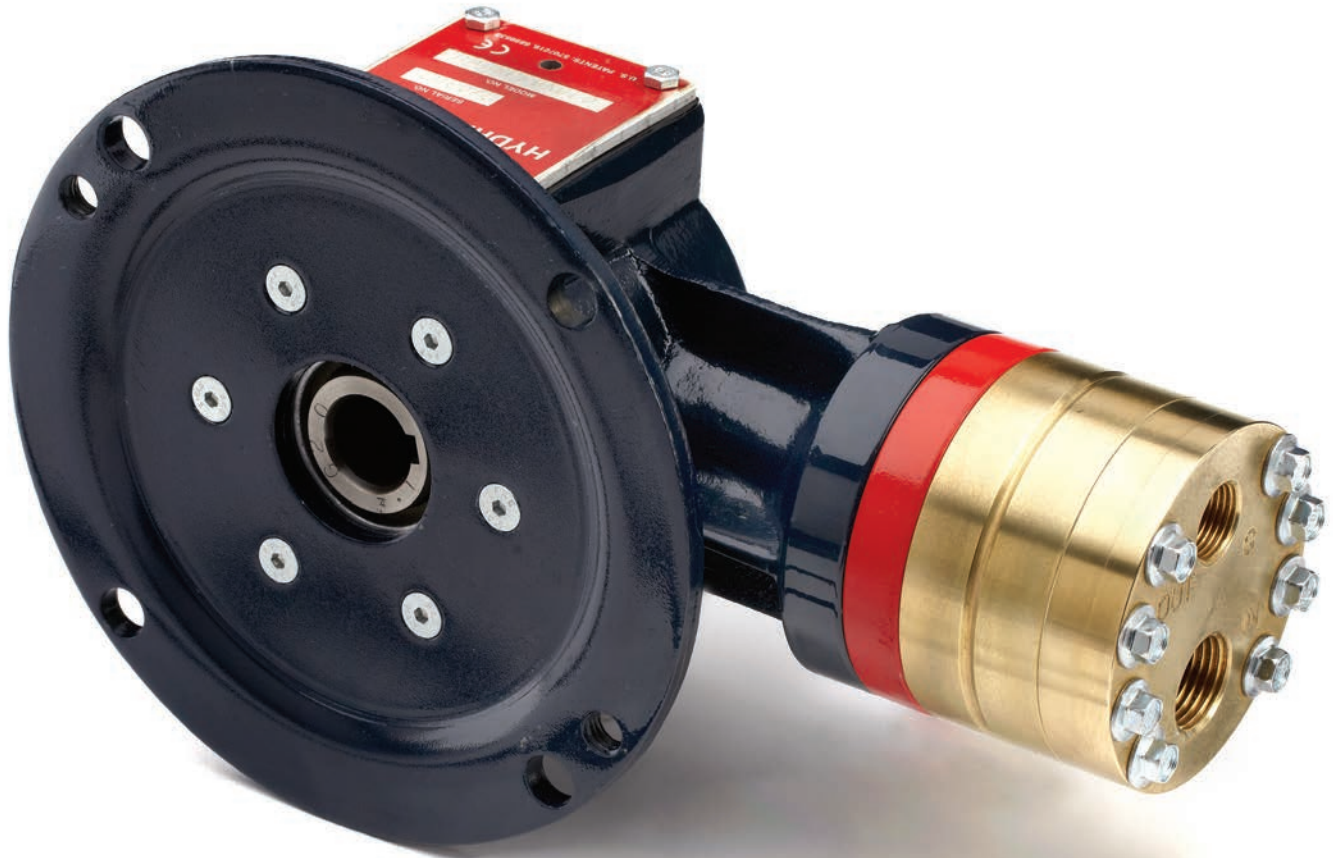

*G20 close-coupled (hollow shaft) for 56C frame motors, shown with Brass pump head.*

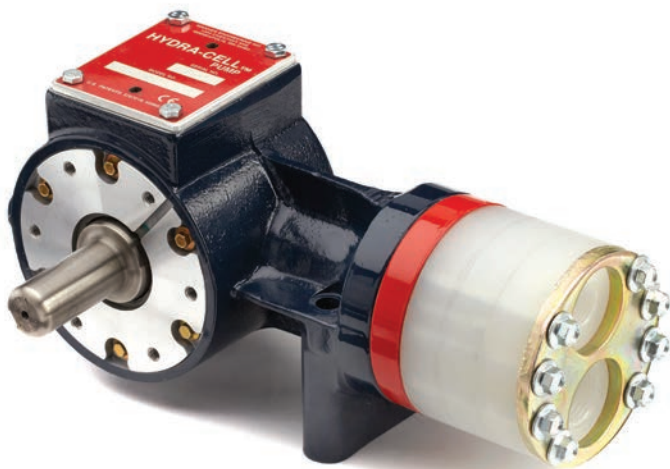

*G21 external shaft-driven with Polypropylene pump head.*



*G22 flexible-coupled to 56C, 142TC, and 145TC frame motors, shown with 316L Stainless Steel pump head.*

# G20 Series Performance

## Capacities

### Flow

Model	Max. Input rpm	Max. Flow @ 1000 psi (69 bar)	
		gpm	l/min
G20-X	1750	1.01	3.82
G20-E	1750	0.71	2.69
G20-S	1750	0.56	2.12
G20-B	1750	0.31	1.17
G20-G	1750	0.20	0.76

### Pressure

**Maximum Inlet Pressure**  
250 psi (17 bar)

#### Maximum Discharge Pressure

Metallic Pump Heads:

G20 to 1000 psi (69 bar)

G21 to 1500 psi (103 bar)

G22 to 1500 psi (103 bar)

Non-metallic Pump Heads:

250 psi (17 bar) Polypropylene

350 psi (24 bar) PVDF

Performance and specification ratings apply to G20, G21 and G22 configurations unless specifically noted otherwise.

## Maximum Flow at Designated Pressure

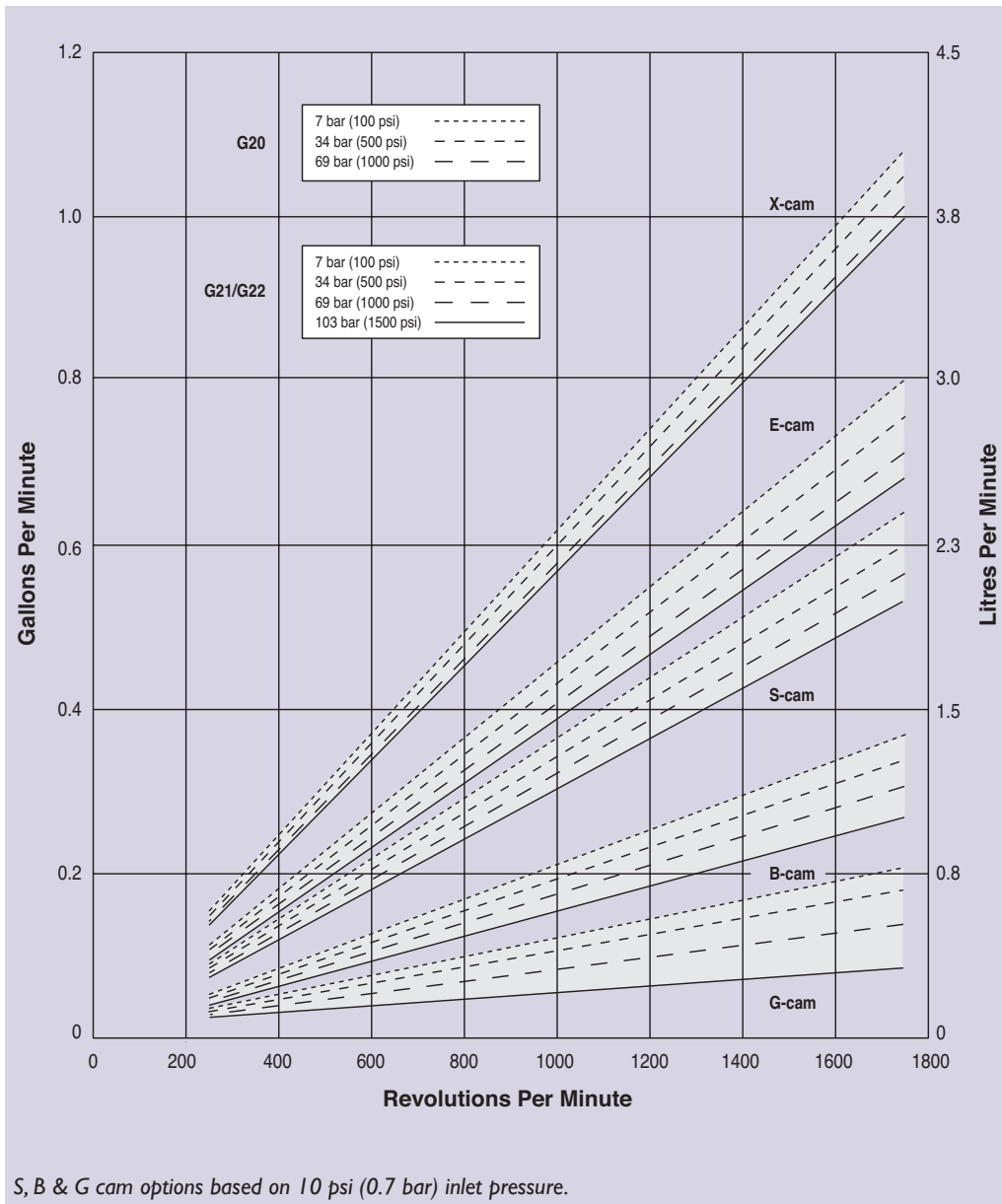

S, B & G cam options based on 10 psi (0.7 bar) inlet pressure.

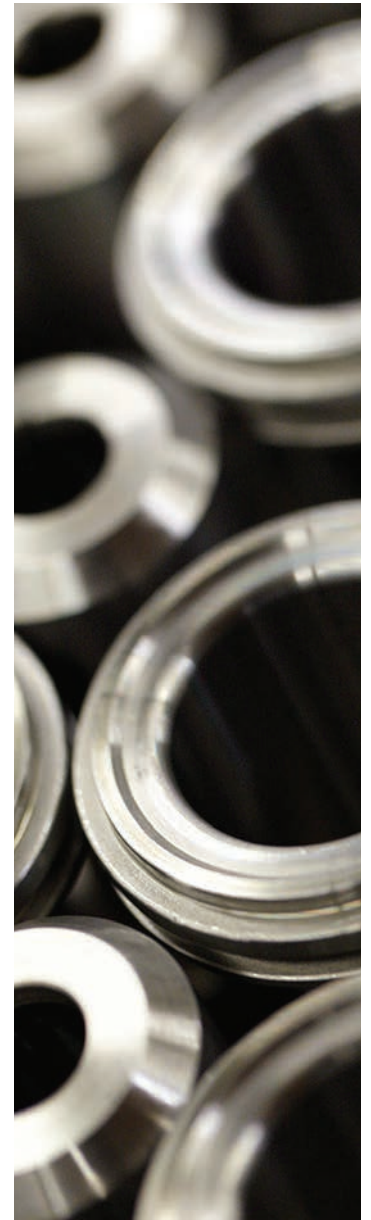

# G20 Series Specifications

## Flow Capacities @ 69 bar (1000 psi) 4-pole Motor @ 50 Hz

Model	rpm	gpm	l/min
G20-X	1450	0.83	3.14
G20-E	1450	0.60	2.29
G20-S	1450	0.45	1.72
G20-B	1450	0.27	1.03
G20-G	1450	0.16	0.63

## Flow Capacities @ 69 bar (1000 psi) 6-pole Motor @ 50 Hz

Model	rpm	gpm	l/min
G20-X	960	0.55	2.08
G20-E	960	0.40	1.51
G20-S	960	0.30	1.14
G20-B	960	0.18	0.68
G20-G	960	0.10	0.41

## Delivery @ 69 bar (1000 psi)

Model	gal/rev	liters/rev
G20-X	0.0006	0.0022
G20-E	0.0004	0.0015
G20-S	0.0003	0.0012
G20-B	0.0002	0.0007
G20-G	0.0001	0.0004

## Maximum Discharge Pressure

Metallic Heads: G20 to 69 bar (1000 psi)  
G21 to 103 bar (1500 psi)  
G22 to 103 bar (1500 psi)

Non-metallic Heads: 17 bar (250 psi) Polypropylene  
24 bar (350 psi) PVDF

## Maximum Inlet Pressure 17 bar (250 psi)

## Maximum Operating Temperature

Metallic Heads: 121 °C (250 °F) - Consult factory for correct component selection for temperatures from 71 °C (160 °F) to 121 °C (250 °F).

Non-metallic Heads: 60 °C (140 °F)

## Maximum Solids Size 200 microns

## Inlet Port 1/2 inch BSPT 1/2 inch NPT

## Discharge Port 3/8 inch BSPT 3/8 inch NPT

## Shaft Diameter G20: 15.9 mm hollow shaft G21 & G22: 15.9 mm (5/8 inch)

## Shaft Rotation Reverse (bi-directional)

## Bearings Precision ball bearings

## Oil Capacity 0.12 liters (0.125 US quart)

## Weight

Metallic Heads: 5.5 kg (12 lbs.)

Non-metallic Heads: 4.1 kg (9 lbs.)

## Net Positive Suction Head (NPSHr)

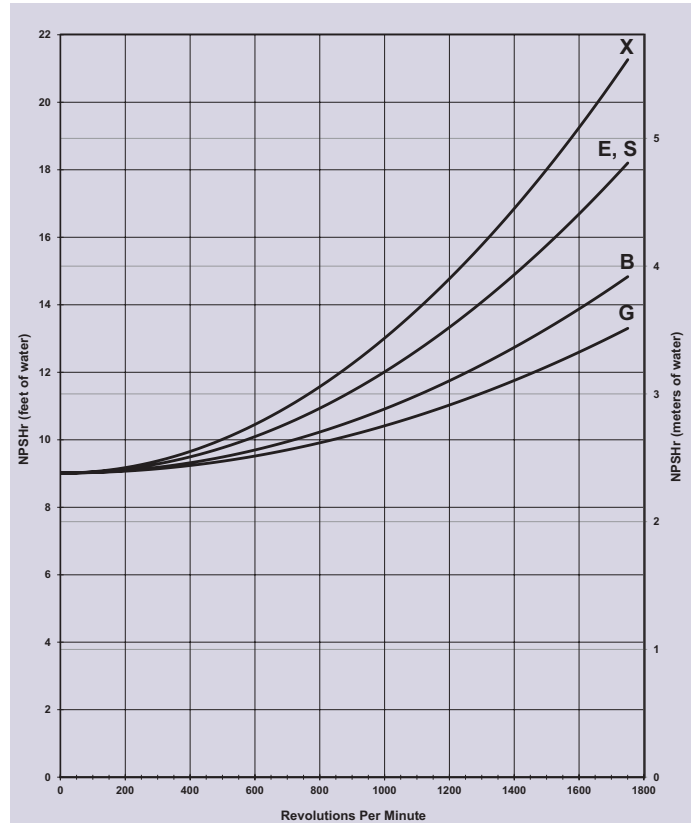

Positive inlet pressure required for:

- A) All pumps with PTFE diaphragms
- B) Pumps with B-cam or G-cam (consult factory)

## Suction Lift:

Each Hydra-Cell pump has different lift capability depending on model size, cam angle, speed, and fluid characteristics. To ensure that your specific lift characteristics are met, refer to the inlet calculations regarding friction, and acceleration head losses in your Hydra-Cell Installation & Service Manual. Compare those calculations to the NPSHr curves above.

## Calculating Required Power

$$\frac{\text{rpm} + 1000}{7000} + \frac{\text{gpm} \times \text{psi}}{1,460} = \text{electric motor hp}$$

$$\frac{\text{rpm} + 1000}{9383} + \frac{\text{l/min} \times \text{bar}}{511} = \text{electric motor kW}$$

When using a variable frequency drive (VFD) controller calculate the hp or kW at minimum and maximum pump speed to ensure the correct hp or kW motor is selected. Note that motor manufacturers typically de-rate the service factor to 1.0 when operating with a VFD.

## Calculating Pulley Size

$$\frac{\text{motor pulley OD}}{\text{pump rpm}} = \frac{\text{pump pulley OD}}{\text{motor rpm}}$$

# G20 Series Representative Drawings

## G20 Models with Metallic Pump Head mm (Inches)

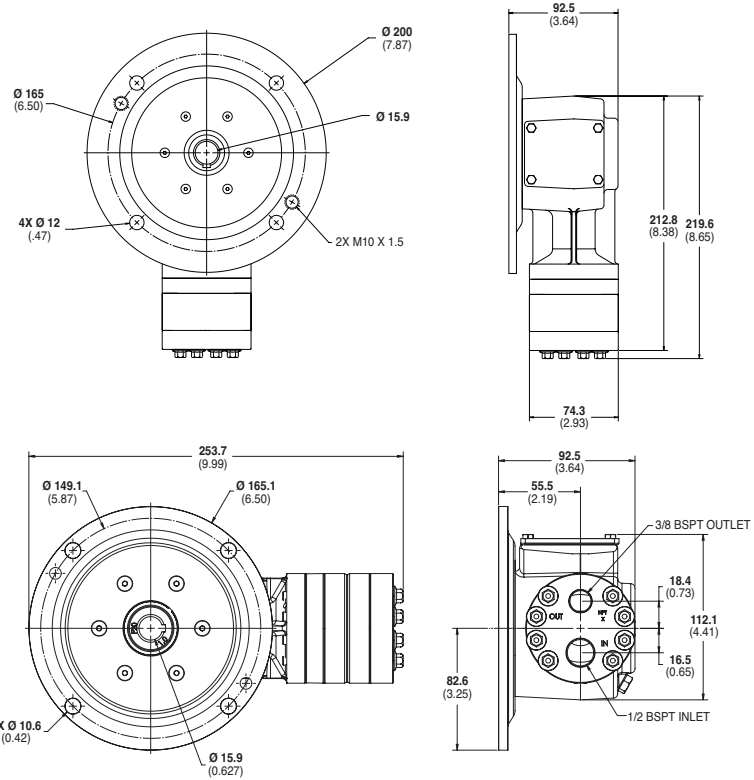

\* Add 6.35mm (0.25") where shown for manifold cover plate on non-metallic models.

## G21 Models with Metallic Pump Head mm (Inches)

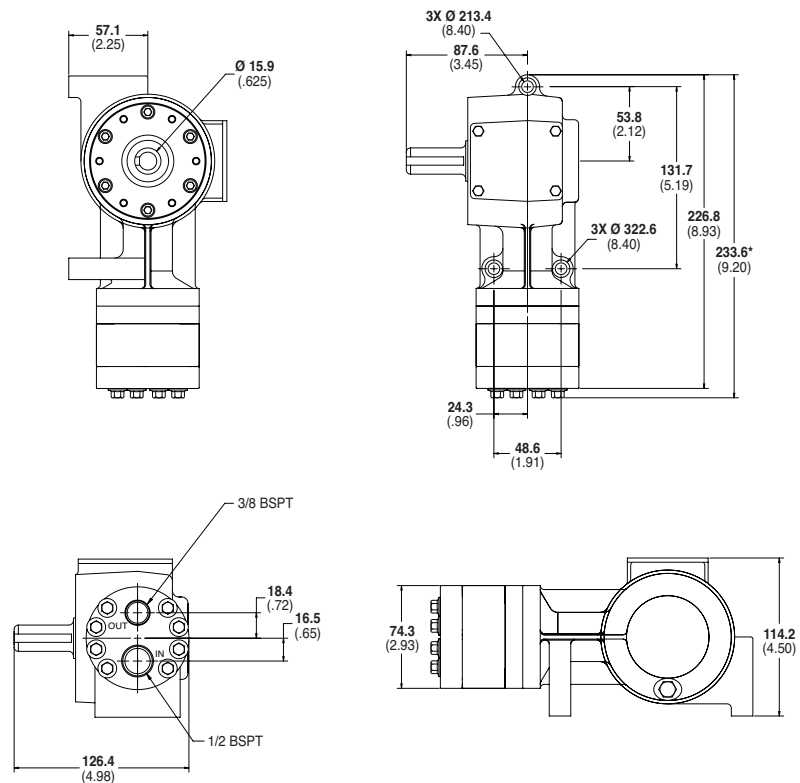

\* Add 6.35mm (0.25") where shown for manifold cover plate on non-metallic models.

**Note:** Dimensions are for reference only. Contact factory for certified drawings.

# G20 Series Drawings/Adapters/Valves

## G22 Models with Metallic Pump Head mm (Inches)

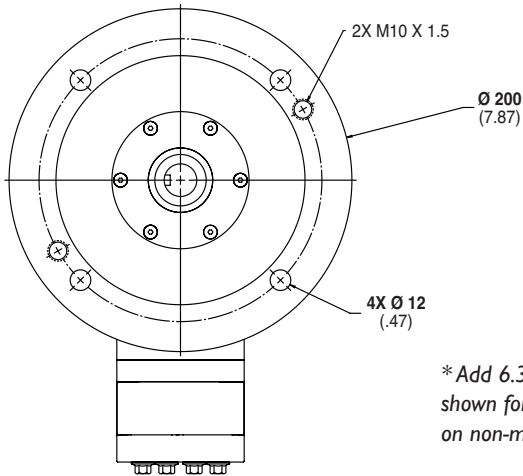

\* Add 6.35mm (0.25") where shown for manifold cover plate on non-metallic models.

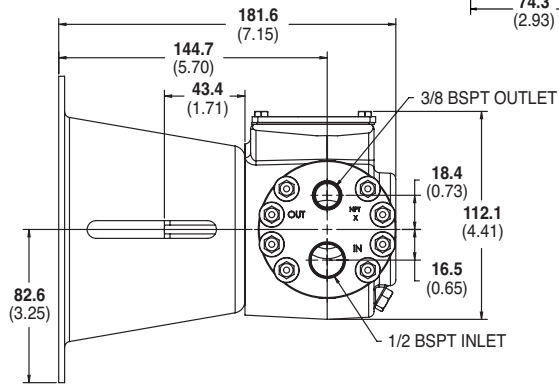
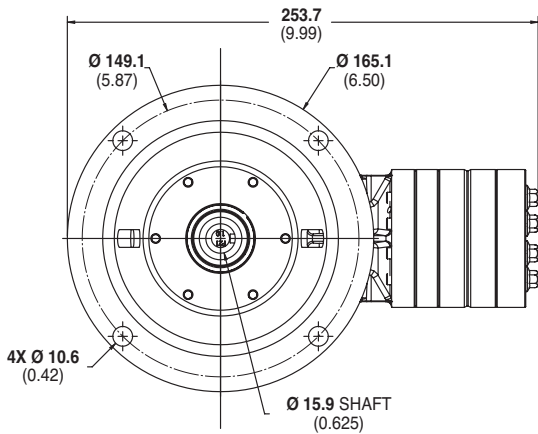
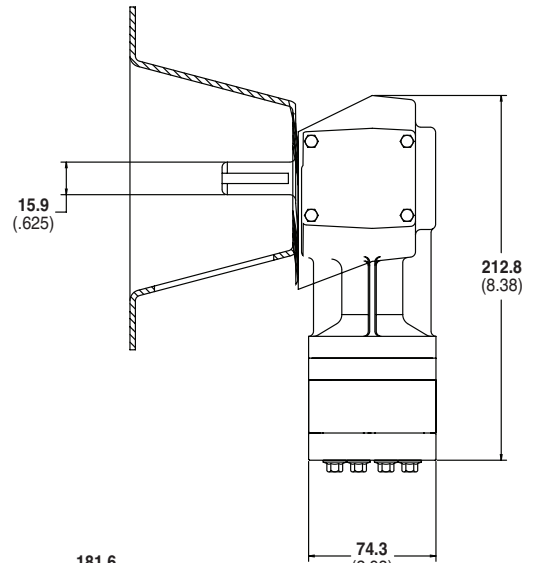

**Note:** Dimensions are for reference only. Contact factory for certified drawings.

### Pump/Motor Adapter (mm) Inches

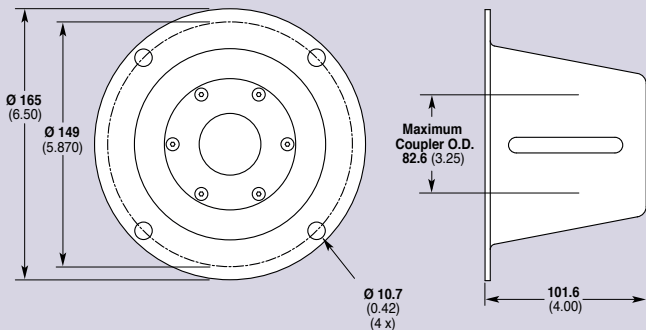

#### Part Number: A04-006-1200

Must be ordered separately for G22 models (optional for G21 models) for use with IEC 80 - 90 frame motors, B5 flange.

NEMA adapter available - consult factory.

### Valve Selection

A Hydra-Cell G20, G21 or G22 pumping system uses a C46 Pressure Regulating Valve.



For complete specifications and ordering information, consult the Hydra-Cell Master Catalog.

# G20 Series How to Order

## Ordering Information

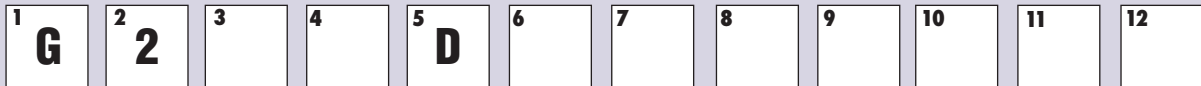

A complete G20 Series Model Number contains 12 digits including 9 customer-specified design and materials options, for example: G20GDPGHFEFG.

Digit	Order Code	Description
<b>1-3</b>		<b>Pump Configuration</b>
	<b>G20</b>	Close-coupled to IEC 80 footed motor (BSPT Ports)
	<b>G21</b>	Shaft-driven (BSPT Ports)*
	<b>G22</b>	For use with pump/motor adapter (BSPT Ports)*
		*Pump/motor adapters ordered separately. See previous page.
<b>4</b>		<b>Hydraulic End Cam</b>
	<b>X</b>	Max 3.1 l/min (0.8 gpm) @ 1450 rpm
	<b>E</b>	Max 2.3 l/min (0.6 gpm) @ 1450 rpm
	<b>S</b>	Max 1.7 l/min (0.4 gpm) @ 1450 rpm
	<b>B</b>	Max 1.0 l/min (0.3 gpm) @ 1450 rpm**
	<b>G</b>	Max 0.6 l/min (0.2 gpm) @ 1450 rpm**
<b>5</b>		<b>Pump Head Version</b>
	<b>D</b>	BSPT Ports (for all G20, G21 & G22 pumps)
<b>6</b>		<b>Pump Head Material</b>
	<b>B</b>	Brass
	<b>M</b>	PVDF
	<b>P</b>	Polypropylene
	<b>S</b>	316L Stainless Steel
	<b>T</b>	Hastelloy C
<b>7</b>		<b>Diaphragm &amp; O-ring Material</b>
	<b>A</b>	Aflas diaphragm/PTFE o-ring
	<b>E</b>	EPDM (requires EPDM-compatible oil - Digit 12 oil code J)
	<b>G</b>	FKM
	<b>J</b>	PTFE (available with X and E cams only)**
	<b>P</b>	Neoprene
	<b>T</b>	Buna-N
<b>8</b>		<b>Valve Seat Material</b>
	<b>C</b>	Ceramic
	<b>D</b>	Tungsten Carbide
	<b>H</b>	17-4 Stainless Steel
	<b>S</b>	316L Stainless Steel
	<b>T</b>	Hastelloy C

Digit	Order Code	Description
<b>9</b>		<b>Valve Material</b>
	<b>C</b>	Ceramic
	<b>D</b>	Tungsten Carbide
	<b>F</b>	17-4 Stainless Steel
	<b>N</b>	Nitronic 50
	<b>T</b>	Hastelloy C
<b>10</b>		<b>Valve Springs</b>
	<b>E</b>	Elgiloy
	<b>T</b>	Hastelloy C
<b>11</b>		<b>Valve Spring Retainers</b>
	<b>C</b>	Celcon
	<b>H</b>	17-7 Stainless Steel (used with metallic heads only)
	<b>M</b>	PVDF
	<b>P</b>	Polypropylene
	<b>T</b>	Hastelloy C (used with metallic heads only)
	<b>Y</b>	Nylon
<b>12</b>		<b>Hydra-Oil</b>
	<b>G</b>	5W30 cold-temp severe-duty synthetic oil
	<b>J</b>	EPDM-compatible oil
	<b>K</b>	Food-contact oil

### Consult the Hydra-Cell Master Catalog for:

- Motors, bases, couplings and other pump accessories
- Hydra-Oil selection and specification information
- Design considerations, installation guidelines, and other technical assistance in pump selection

\*\*Positive inlet pressure required for B and G cams and for PTFE diaphragms.

# Hydra-Cell®

## Seal-less Pumps

### Wanner Engineering, Inc.

#### World Headquarters & Manufacturing

Wanner Engineering, Inc.  
1204 Chestnut Avenue  
Minneapolis, MN 55403 USA  
Phone: 612-332-5681 • Fax: 612-332-6937  
Toll-Free Fax (USA): 800-332-6812  
Email: [sales@wannereng.com](mailto:sales@wannereng.com)  
[www.Hydra-Cell.com](http://www.Hydra-Cell.com)

#### Regional Office

207 US Highway 281  
Wichita Falls, TX 76310 USA  
Phone: 940-322-7111  
Toll-Free: 800-234-1384  
Email: [sales@wannereng.com](mailto:sales@wannereng.com)  
[www.Hydra-Cell.com](http://www.Hydra-Cell.com)

#### Latin American Office

Avenida Senador Vergueiro 608 – Centro  
São Bernardo do Campo/São Paulo, Brazil  
CEP 09750-000  
Phone: +55 (11) 99582-1969  
Email: [mmagoni@wannereng.com](mailto:mmagoni@wannereng.com)  
[www.Hydra-Cell-Pumps.com.br](http://www.Hydra-Cell-Pumps.com.br)

### Wanner International Ltd.

Wanner International, Ltd.  
Hampshire - United Kingdom  
Phone: +44 (0) 1252 816847  
Email: [sales@wannerint.com](mailto:sales@wannerint.com)  
[www.Hydra-Cell.co.uk](http://www.Hydra-Cell.co.uk)

### Wanner Pumps Ltd.

Wanner Pumps, Ltd.  
Kowloon - Hong Kong  
Phone: +852 3428 6534  
Email: [sales@wannerpumps.com](mailto:sales@wannerpumps.com)  
[www.WannerPumps.com](http://www.WannerPumps.com)

Shanghai - China  
Phone: +86-21-6876 3700  
Email: [sales@wannerpumps.com](mailto:sales@wannerpumps.com)  
[www.WannerPumps.com](http://www.WannerPumps.com)

