

Hydra-Cell[®]

Seal-less Pumps

Versatile, Reliable Pumps for a Wide Range of Applications



Now Featuring Optimized Valve Plate for Improved Performance, Pump Safety & Reliability.

DI2 Series

- Pumps the full spectrum of low-to-high viscosity fluids.
- Features a seal-less design and horizontal disk check valves that enable the pump to handle abrasives and particulates that might damage or destroy other types of pumps.
- Simple, compact design reduces initial investment and lowers maintenance costs.
- Operational efficiencies reduce energy costs.
- Able to run dry without damage (or additional maintenance) to the pump in case of accident or operator error.
- Tolerates non-ideal operating conditions.
- Minimizes maintenance and downtime because there are no mechanical or dynamic seals, packing, or cups to leak, wear, or replace.

D12 Series

Maximum Flow Rate: 8.8 gpm (33.4 l/min)

Maximum Pressure: 1000 psi (69 bar) for Metallic Pump Heads



D12 equipped with Model C62 Pressure Regulating Valve and Valve/Tube Accessory, shown with Cast Iron pump head.

D12 Series Performance

Capacities

Flow

model	Max. Input rpm	Max. Flow @ 1000 psi (69 bar)	
		gpm	l/min
D12-X	1450	8.1	30.6
D12-E	1750	8.8	33.4
D12-S	1750	6.0	22.7
D12-I	1750	4.0	15.0

Pressure

Maximum Inlet Pressure
250 psi (17 bar)

Maximum Discharge Pressure
1000 psi (69 bar)

Performance and specification ratings apply to D12 configurations unless specifically noted otherwise.

Maximum Flow at Designated Pressure

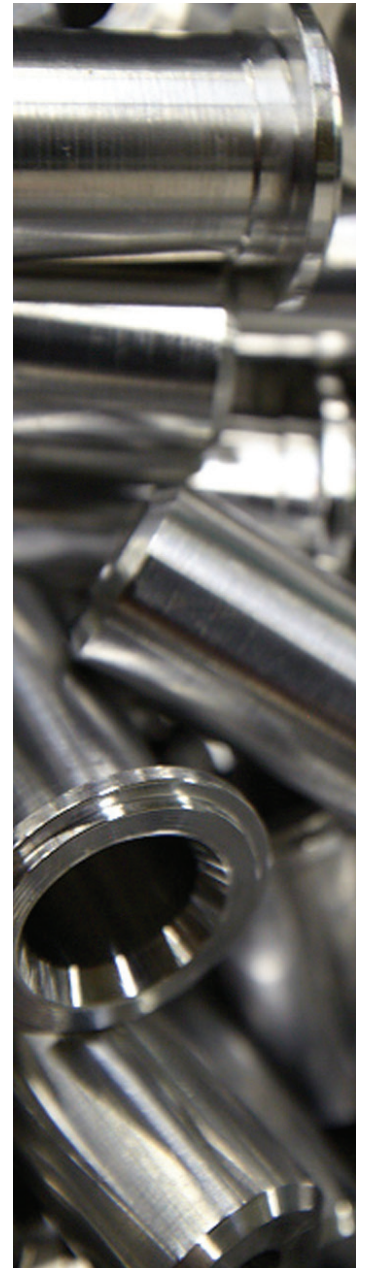
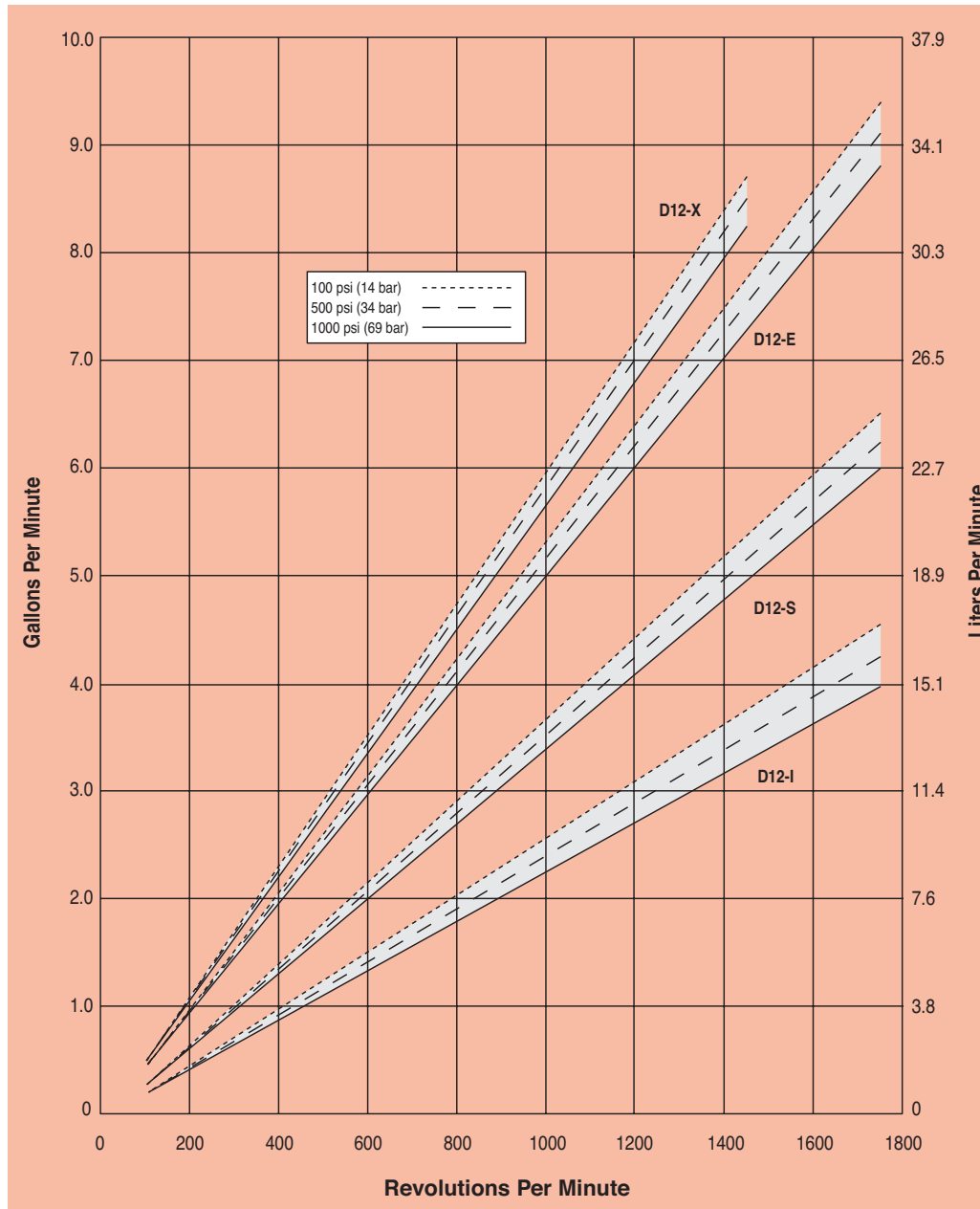

D12 Series Specifications

Flow Capacities @1000 psi (69 bar)

Model	rpm	gpm	l/min
D12-X	1450	8.10	30.6
D12-E	1750	8.83	33.4
D12-S	1750	6.00	22.7
D12-I	1750	3.96	15.0

Delivery @1000 psi (69 bar)

Model	gal/rev	liters/rev
D12-X	0.0056	0.0211
D12-E	0.0051	0.0191
D12-S	0.0034	0.0130
D12-I	0.0023	0.0086

Maximum Discharge Pressure

Metallic Heads: 1000 psi (69 bar)

Maximum Inlet Pressure 250 psi (17 bar)

Maximum Operating Temperature

Metallic Heads: 250 °F (121 °C) - Consult factory for correct component selection for temperatures from 160 °F (71 °C) to 250 °F (121 °C).

Maximum Solids Size 500 microns

Inlet Port 1 inch NPT

Discharge Port 3/4 inch NPT

Shaft Diameter 7/8 inch (22.2 mm)

Shaft Rotation Reverse (bi-directional)

Bearings Tapered roller bearings

Oil Capacity 1.5 US quarts (1.4 liters)

Weight

Metallic Heads: 63 lbs. (28.6 kg)

Net Positive Suction Head (NPSHr)

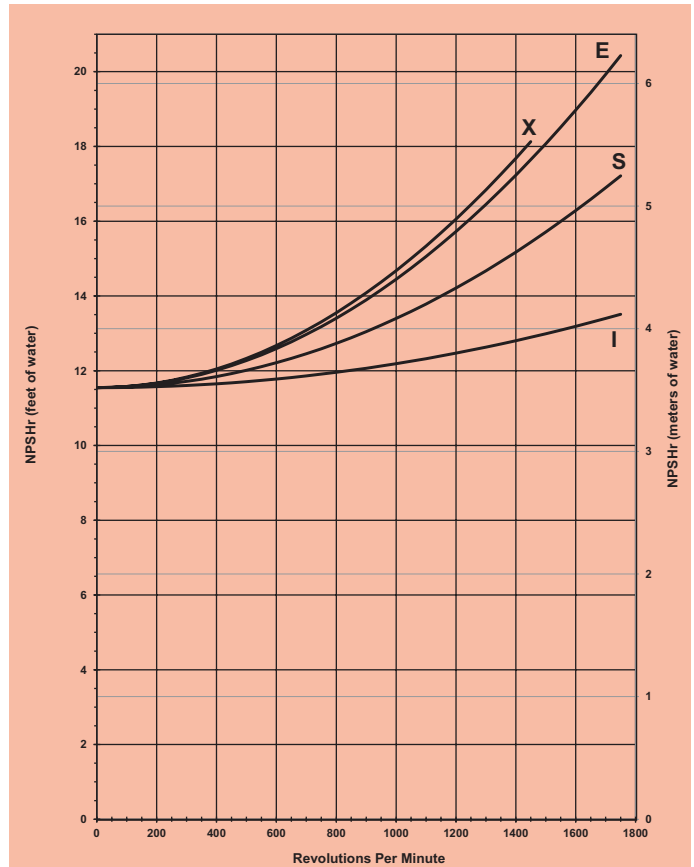

Positive inlet pressure required for:

- A) All pumps with PTFE diaphragms
- B) Pumps with I-cam (consult factory)

Calculating Required Power

$$\frac{15 \times \text{rpm}}{63,000} + \frac{\text{gpm} \times \text{psi}}{1,460} = \text{electric motor hp}$$

$$\frac{15 \times \text{rpm}}{84,428} + \frac{\text{l/min} \times \text{bar}}{511} = \text{electric motor kW}$$

When using a variable frequency drive (VFD) controller, calculate the hp or kW at minimum and maximum pump speed to ensure the correct hp or kW motor is selected. Note that motor manufacturers typically de-rate the service factor to 1.0 when operating with a VFD.

Suction Lift:

Each Hydra-Cell pump has different lift capability depending on model size, cam angle, speed, and fluid characteristics. To ensure that your specific lift characteristics are met, refer to the inlet calculations regarding friction, and acceleration head losses in your Hydra-Cell Installation & Service Manual. Compare those calculations to the NPSHr curves above.

DI2 Series Representative Drawings

DI2 Standard Configuration (Metallic Pump Heads) Inches (mm)

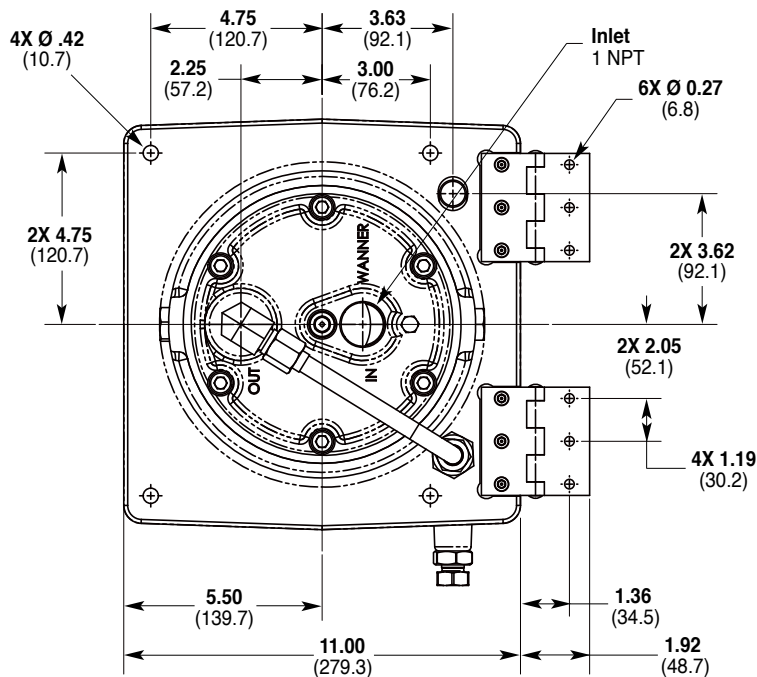
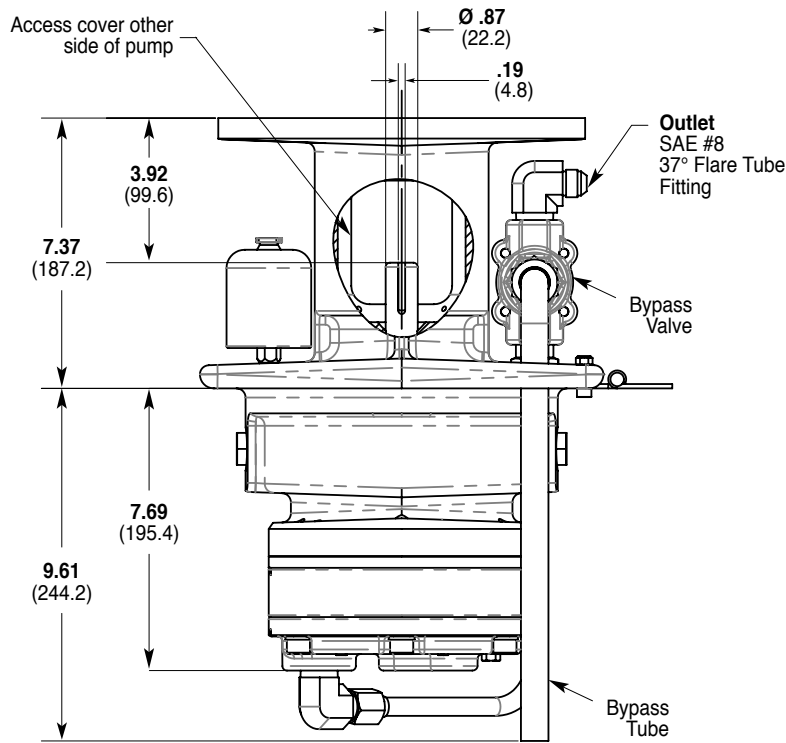

Note: Dimensions are for reference only. Contact factory for certified drawings.

DI2 Series Representative Drawings

DI2 with Tube Accessory Inches (mm)

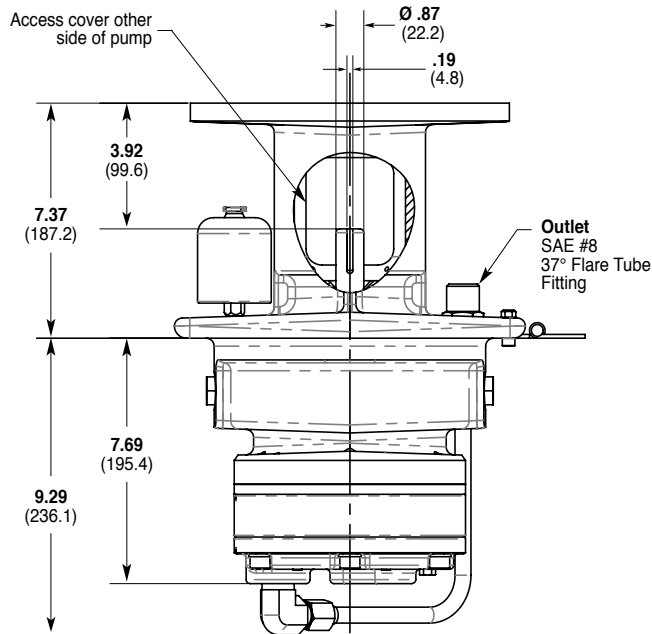

DI2 with Valve/Tube Accessory Inches (mm)

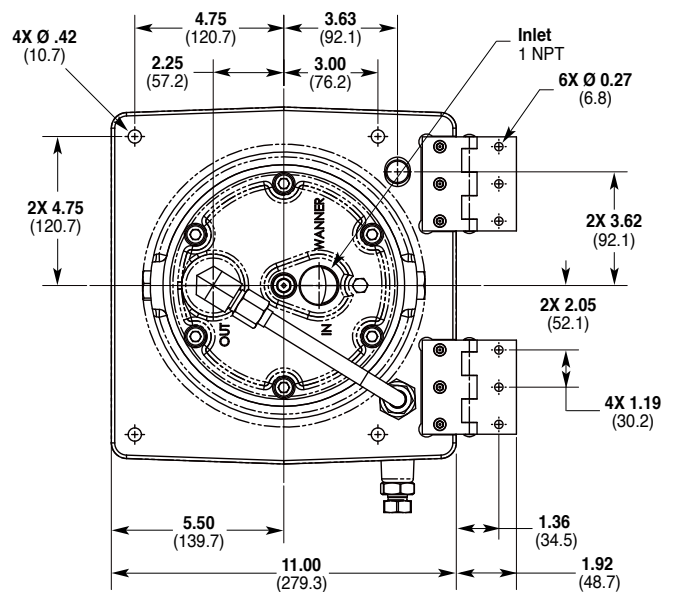
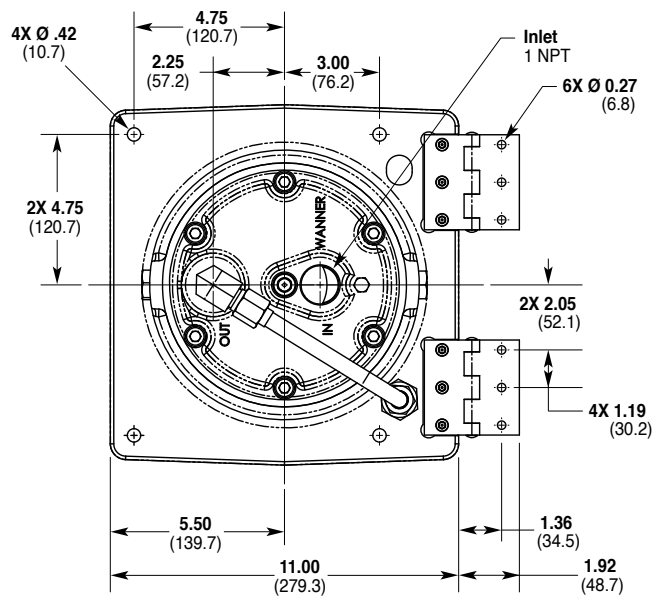
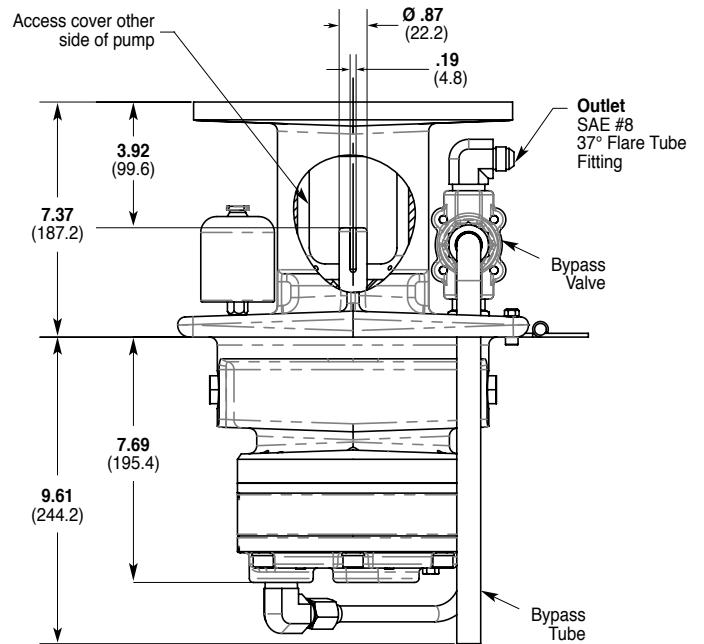

Note: Dimensions are for reference only. Contact factory for certified drawings.

D12 Series Representative Drawings

D12 Models with Minimum Tank Size and Critical Installation Dimensions Inches (mm)

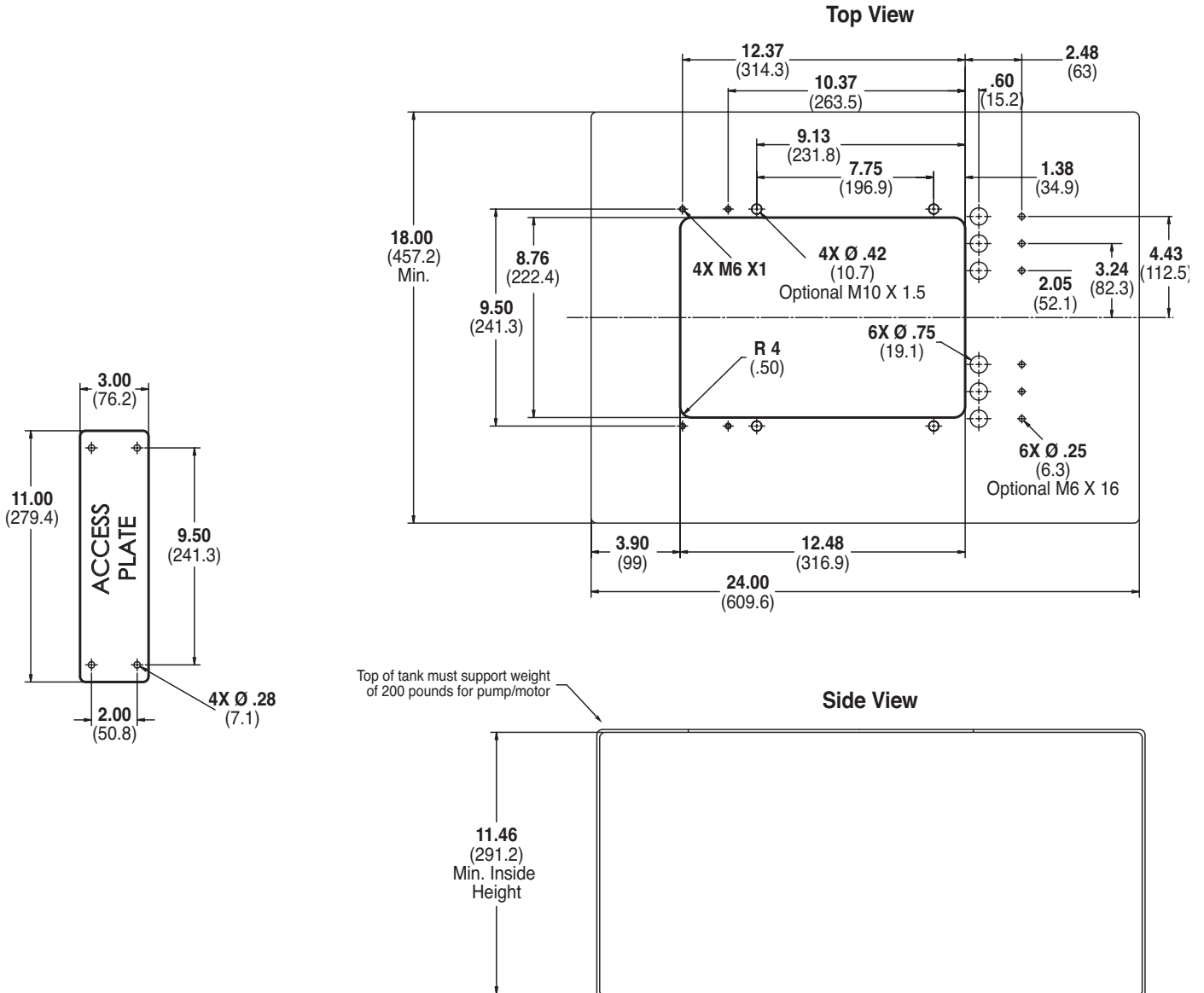

Note: Dimensions are for reference only. Contact factory for certified drawings.

D12 Series **Valve/Tube Accessories**

The Hydra-Cell D12 Tube and Valve/Tube Accessories provide a pre-fabricated plumbing package for simplified installation.
(See page 6 for dimensions.)

Ordering Information

Tube Accessory Part Number: A04-007-1200

Valve/Tube Accessory Part Number: A04-008-1200



Valve Selection

A seal-less C62 Pressure Regulating Valve is recommended for Hydra-Cell D12 pumping systems, especially for high-pressure requirements or when handling dirty fluids.



A C22 Pressure Regulating Valve provides a capable, lower-cost alternative to C62 valves for Hydra-Cell D12 pumping systems.



For complete specifications and ordering information, consult the Hydra-Cell Master Catalog.

D12 Series **How to Order**

Ordering Information



A complete D12 Series Model Number contains 12 digits including 8 customer-specified design and materials options, for example: D12XKCGHFCEA.

Digit	Order Code	Description
1-3	D12	Pump Configuration Flanged for NEMA 182/184TC, 213/215TC (NPT Ports)* *Tube Accessory Kits ordered separately. See previous page.
4	X	Hydraulic End Cam Max 8.1 gpm (30.6 l/min) @ 1450 rpm
	E	Max 8.8 gpm (33.4 l/min) @ 1750 rpm
	S	Max 6.0 gpm (22.7 l/min) @ 1750 rpm
	I	Max 4.0 gpm (15.0 l/min) @ 1750 rpm
5	K	Pump Head Version Kel-Cell NPT Ports
	R	Kel-Cell NPT Ports with Optimized Valve Pocket
6	B	Pump Head Material Brass
	C	Cast Iron (Nickel-plated)
	S	316L Stainless Steel
7	E	Diaphragm & O-ring Material EPDM (requires EPDM-compatible oil - Digit 12 oil code C)
	G	FKM
	J	PTFE (available with E and S cams only; 1200 rpm max.)
	P	Neoprene
	T	Buna-N
8	C	Valve Seat Material Ceramic
	D	Tungsten Carbide
	H	17-4 Stainless Steel
	S	316L Stainless Steel
9	C	Valve Material Ceramic
	D	Tungsten Carbide
	F	17-4 Stainless Steel
	N	Nitronic 50
10	E	Valve Springs Elgiloy

Digit	Order Code	Description
11	C	Valve Spring Retainers Celcon
	H	17-7 Stainless Steel
	M	PVDF
	P	Polypropylene
	Y	Nylon (Zytel)
12	A	Hydra-Oil 10W30 standard-duty oil
	B	40-wt for continuous-duty (use with 316L SST pump head - standard)
	C	EPDM-compatible oil
	E	Food-contact oil
	G	5W30 cold-temp severe-duty synthetic oil

Consult the Hydra-Cell Master Catalog for:

- Motors, bases, couplings and other pump accessories
- Hydra-Oil selection and specification information
- Design considerations, installation guidelines, and other technical assistance in pump selection

Hydra-Cell®

Seal-less Pumps



Wanner Engineering, Inc.

World Headquarters & Manufacturing

Wanner Engineering, Inc.
1204 Chestnut Avenue
Minneapolis, MN 55403 USA
Phone: 612-332-5681 • Fax: 612-332-6937
Toll-Free Fax (USA): 800-332-6812
Email: sales@wannereng.com
www.Hydra-Cell.com

Regional Office

207 US Highway 281
Wichita Falls, TX 76310 USA
Phone: 940-322-7111
Toll-Free: 800-234-1384
Email: sales@wannereng.com
www.Hydra-Cell.com

Latin American Office

Avenida Senador Vergueiro 608 - Centro
São Bernardo do Campo/São Paulo, Brazil
CEP 09750-000
Phone: +55 (11) 99582-1969
Email: mmagoni@wannereng.com
www.Hydra-Cell-Pumps.com.br



Wanner International Ltd.

Wanner International, Ltd.
Hampshire - United Kingdom
Phone: +44 (0) 1252 816847
Email: sales@wannerint.com
www.Hydra-Cell.co.uk



Wanner Pumps Ltd.

Wanner Pumps, Ltd.
Kowloon - Hong Kong
Phone: +852 3428 6534
Email: sales@wannerpumps.com
www.WannerPumps.com

Shanghai - China
Phone: +86-21-6876 3700
Email: sales@wannerpumps.com
www.WannerPumps.com

