



FINISH THOMPSON INC.

PF SERIES PUMPS

PFS OPERATION & PARTS MANUAL

For Serial Number 162859 & above
P/N 108098 Rev 9





FINISH THOMPSON INC.

921 Greengarden Road • Erie, PA 16501-1591 U.S.A.
Ph 814-455-4478 • Fax 814-455-8518
Email fti@finishthompson.com • www.finishthompson.com

EU Declaration of Conformity



Finish Thompson Inc. hereby declares that the following machine(s) fully comply with the applicable health and safety requirements as specified by the EU Directives listed. The product may not be taken into service until it has been established that the drive motor for the centrifugal pump complies with the provisions of all relevant EU Directives. The complete product complies with the provisions of the EU Directive on machinery safety provided motors carry CE marking.

This declaration is valid provided that the devices are fully assembled and no modifications are made to these devices.

Type of Device:

Drum and Container Pump Tubes/Accessories

Models:

PFS-27/40/48/54/60/72
Nozzles (111030)

EU Directives:

Machinery Safety (2006/42/EC)

Applied Harmonized Standards:

EN ISO 12100:2010
EN 809:1998+A1:2009+AC:2010

Manufacturer: Finish Thompson Inc.
921 Greengarden Road
Erie, Pennsylvania 16501-1591 U.S.A

Signed,

Product Engineer

25 May 2023

Person(s) Authorized to Compile Technical File: Finish Thompson GmbH
Otto-Hahn-Strasse 16
Maintal, D-63477 DEU Telephone:
49 (0)6181-90878-0



FINISH THOMPSON INC.
921 Greengarden Road • Erie, PA 16501-1591 U.S.A.
Ph 814-455-4478 • Fax 814-455-8518
Email fti@finishthompson.com • www.finishthompson.com

Declaration of Conformity



Finish Thompson Inc. hereby declares that the following machine(s) fully comply with the applicable health and safety requirements as specified by the UKCA Directives listed. The product may not be taken into service until it has been established that the drive motor for the Drum and Container Pump complies with the provisions of all relevant UKCA Directives. The complete product complies with the provisions of the UKCA Directive on machinery safety provided motors manufactured by Finish Thompson Inc. are used.

This declaration is valid provided that the devices are fully assembled and no modifications are made to these devices.

Type of Device:

Drum and Container Pump Tubes/Accessories

Models:

PFS-27/40/48/54/60/72
Nozzles (111030)

UKCA Directives (and their applicable amendments):

The Supply of Machinery (Safety) Regulations 2008

Applied Designated Standards:

EN ISO 12100:2010
EN 809:1998+A1:2009+AC:2010

Manufacturer: Finish Thompson Inc.
921 Greengarden Road
Erie, Pennsylvania 16501-1591 U.S.A

Signed,

Product Engineer

30 May 2023

Introduction

This manual pertains to the PF Series, specifically the PFS stainless steel drum pump and accessories. Finish Thompson Inc. thanks you for choosing our products. We believe the use of our products will be fully satisfactory. When properly installed and operated, your Finish Thompson motor and pump will provide long, trouble-free service; therefore, please read this manual carefully before carrying out any operations on the pump/motor unit. Any use other than that described herein is considered incorrect; and, consequently, Finish Thompson Inc. shall not be held responsible for any damages to people or property. In case of doubt or enquiries, please reply to our Technical Service department directly at the following address:

Finish Thompson, Inc.
921 Greengarden Rd.
Erie, PA 16501 U.S.A.
Tel. 1-814-455-4478; Fax 1-814-455-8518
www.finishthompson.com; fti@finishthompson.com

Index

Introduction	4
Warranty, General Terms & Conditions	5
Safety	6
Important Safety Information for Pumping Flammable or Hazardous Substances.....	7
Pump Specifications.....	8
Installation	9
Operation	9
Maintenance	9
Disassembly	9
Inspection	9
Reassembly	10
Exploded View	11
Pump Tube Spare Parts List	12-13
Troubleshooting	13

Technical Service Hotline: 1-800-888-3743 or email techservice@finishthompson.com

Warranty, General Terms & Conditions

Finish Thompson, Inc (manufacturer) warrants this pump product to be free of defects in materials and workmanship for a period of one year from date of purchase by original purchaser. If a warranted defect, which is determined by manufacturer's inspection, occurs within this period, it will be repaired or replaced at the manufacturer's option, provided (1) the product is submitted with proof of purchase date and (2) transportation charges are prepaid to the manufacturer. Liability under this warranty is expressly limited to repairing or replacing the product or parts thereof and is in lieu of any other warranties, either expressed or implied. This warranty does not apply to normal wear of the product or components. This warranty does not apply to products or parts broken due to, in whole or in part, accident, overload, abuse, chemical attack, tampering, or alteration. The warranty does not apply to any other equipment used or purchased in combination with this product. The manufacturer accepts no responsibility for product damage or personal injuries sustained when the product is modified in any way. If this warranty does not apply, the purchaser shall bear all cost for labor, material and transportation.

Manufacturer shall not be liable for incidental or consequential damages including, but not limited to, process down time, transportation costs, costs associated with replacement or substitution products, labor costs, product installation or removal costs, or loss of profit. In any and all events, manufacturer's liability shall not exceed the purchase price of the product and/or accessories.

Warranty Registration

Thank you for your purchase of this quality Finish Thompson product. Be sure to take a minute to register your pump at Finishthompson.com/warranty. Simply provide the model number, serial number and a few other pieces of information.

Safety

1. Introduction

This manual contains all the information needed for the correct installation, use and maintenance of your new Finish Thompson pump and accessories. It should be read and understood by all the personnel involved in installation, operating and servicing of the pump before it is started.

2. Operator Qualification and Training

The personnel in charge of the installation, the operation, and the maintenance of the pump must be qualified and able to perform the operations described in this manual. Finish Thompson, Inc. shall not be held responsible for the training level of personnel and for the fact that they are not fully aware of the contents of this manual.

3. Safety Instructions

FOR YOUR OWN SAFETY

BEFORE using or servicing your pump or accessories, please make sure to wear the proper clothing, eye protection and follow standard safety procedures when handling corrosive or personally harmful materials.

GENERAL DANGER

ALWAYS use a stainless steel pump tube with an explosion proof electric motor or air motor and static protection kit with grounded discharge hose when pumping or mixing flammable or combustible material.

ALWAYS ensure the pump, hose, and motor are bonded to ground, and the tanks/containers are separately bonded to ground.

ALWAYS inspect the integrity of the ground wire connections prior to each use.

NEVER leave the pump unattended while in use.

NEVER run the pump dry without fluid.

NEVER run the pump with a closed valve (deadhead) for longer than 1 minute.

ALWAYS use and store the pump and motor in an upright position.

NEVER use in pressurized containers.

ALWAYS use a chemically compatible hose rated for the temperature of the product being pumped.

ALWAYS tighten and torque a stainless steel hose clamp to 25 in-lbs (2.8 N·m)

ALWAYS select the proper o-ring material. Improper material selection could lead to swelling and be a possible source of leaks. This is the responsibility of the end user.

ALWAYS check the pump for leaks on a regular basis. If leaks are noticed, the pump must be repaired or replaced immediately.

DANGER: POWER SUPPLY

Refer to instructions for the appropriate motor in the Operation & Installation Manual - Drum Pump Motors.

4. Noise Level

Refer to specifications in the Operation & Installation Manual - Drum Pump Motors.

5. Modifications and Spare Parts

Any changes concerning the service of the pump or accessories as originally purchased can be executed only after written approval from Finish Thompson Inc. It is recommended to use only genuine Finish Thompson Inc. spare parts and approved accessories. The use of non-original spare parts or non-approved accessories will void warranty and removes any responsibility on the manufacturer's behalf for any damage caused to people or things.

6. Cleaning

It is highly recommended to flush pumps and accessories with clean water or some other neutralizing fluid compatible with pump materials when done pumping or when switching chemicals.

IMPORTANT SAFETY INFORMATION FOR PUMPING FLAMMABLE OR HAZARDOUS SUBSTANCES

Read these instructions before operating the pump and motor equipment. The manufacturer will not be responsible for any damage to property or to persons caused by improper use of the equipment.

- ⚠ WARNING:** It is the responsibility of the user to operate the pump in conformance with OSHA rules for dispensing liquids. Pump containers should be grounded when using with flammable or combustible liquids to avoid static electricity.
- 1. Use only an explosion-proof rated electric or non-electric (air) motors on stainless steel pump tubes with a Static Protection Kit when transferring flammable or combustible liquids.
- ⚠ WARNING:** Never use an open, splash-proof, TEFC, battery-operated or non-explosion-proof rated motor or a plastic pump tube when transferring flammable or combustible liquids.
- 2. When operating a drum pump (especially when pumping flammable, combustible or hazardous liquids) follow all electrical and safety codes.
 - a) In the United States: the United States Occupational Safety and Health Act (OSHA), most recent National Electrical Code (NEC), National Fire Protection, Inc. (NFPA) Code 30 (Flammable and Combustible Code), NFPA 77 (Static Electricity), NFPA 251 (Standard Method of fire Test of Building Construction), NFPA 704 (Identification of the Fire Hazards of Materials), and other NFPA codes, local codes and ordinances.
 - b) Outside the United States: the ATEX equipment directive 2014/34/EU where applicable, the ATEX workplace 99/92/EC directive where applicable, in addition the precautions of the U.S. codes listed herein and all other local codes and ordinances.
- 3. Pumping hazardous, flammable, or combustible liquids should only be done in buildings, rooms, or areas suited for this purpose. (See NFPA 30, NFPA 78, NFPA 80, NFPA 251, NFPA 704, other suitable NFPA codes, OSHA, ATEX workplace 99/92/EC directive insurance companies, and other local codes and ordinances.)
- 4. When filling cans, drums, etc. with combustible or flammable liquids, both container pumping from and container pumping to, should be bonded and grounded to dissipate possible accumulations of static electricity, and minimize sparks caused by static electricity (refer to NFPA 77 and CLC/TR 60079-32-1 for specific details).
- ⚠ WARNING:** Avoid splashing. Splash filling can create static electricity and is extremely hazardous. Reduce motor speed to prevent splashing.
- ⚠ WARNING:** Fluid velocity must be 3 feet/.9 meter/second maximum (7 gpm/26.5 lpm in 1" hose and 4 gpm/15 lpm in ¾" hose) to reduce risk of static electricity. Reduce motor speed to reduce the fluid velocity.
- 5. Before using, confirm that the pump and any accessories (hose, nozzle, flow meter, etc.) materials of construction are suitable for the material to be pumped and that the maximum temperature is not exceeded.

INFORMATIONS IMPORTANTES SUR LA SÉCURITÉ DURANT LE POMPAGE DE SUBSTANCES INFLAMMABLES OU DANGEREUSES

Veuillez lire attentivement ces instructions avant d'utiliser la pompe et l'équipement du moteur. Le fabricant ne sera pas tenu responsable des dommages matériels ou corporels causés par une utilisation inappropriée de l'équipement.

- ⚠ AVERTISSEMENT:** Il est de la responsabilité de l'utilisateur de faire fonctionner la pompe conformément aux règles OSHA (Santé et Sécurité au Travail) relatives à la distribution de liquides. Les conteneurs de pompes doivent être électriquement mis à la terre lors de l'utilisation de liquides inflammables ou combustibles afin d'éviter toute électricité statique.
- 1. Lors du transfert de liquides inflammables ou combustibles, utilisez uniquement des moteurs électriques ou non électriques (pneumatiques) antidéflagrants sur des tubes de pompe en acier inoxydable dotés d'un dispositif de protection antistatique.
- ⚠ AVERTISSEMENT:** N'utilisez jamais de moteur ouvert, à l'épreuve des éclaboussures, TEFC, alimenté par piles ou non antidéflagrant, ni un tube de pompe en plastique lors du transfert de liquides inflammables ou combustibles.
- 2. Lors de l'utilisation d'une pompe à tambour (en particulier lors du pompage de liquides inflammables, combustibles ou dangereux), respectez tous les codes électriques et les codes de sécurité.
 - a) Aux États-Unis : Loi américaine sur la sécurité et la santé au travail (OSHA); le code national de l'électricité (NEC) le plus récent; le code 30 de la NFPA (code d'inflammabilité et de produits combustibles); le code NFPA 77 (électricité statique); le code NFPA 251 (Méthode standard de test d'incendie de la construction de bâtiments); le code NFPA 704 (Identification des risques d'incendie des matériaux) et autres codes et règlements de la NFPA.
 - b) En dehors des États-Unis : La directive sur les équipements ATEX 2014/34 / EU, le cas échéant, la directive ATEX sur le lieu de travail 99/92 / EC, le cas échéant, ainsi que les précautions des codes des États-Unis énumérés dans la présente et de tous les autres codes, lois et règlements locaux.
- 3. Le pompage de liquides dangereux, inflammables ou combustibles ne doit être effectué que dans des bâtiments, des pièces ou des zones adaptées à cet usage. (Voir NFPA 30, NFPA 78, NFPA 80, NFPA 251, NFPA 704, autres codes NFPA appropriés, OSHA, les directives des compagnies d'assurance ATEX 99/92/CE, et autres codes, lois et règlements locaux.)
- 4. Lors du remplissage de bidons, fûts, etc. avec des liquides combustibles ou inflammables, les conteneurs d'où le liquide est pompé et le conteneur recevant le liquide doivent être reliés et mis à la terre pour éviter toute accumulation éventuelle d'électricité statique et minimiser ainsi les étincelles causées par l'électricité statique (voir NFPA 77). et CLC / TR 60079-32-1 pour des détails spécifiques).
- ⚠ AVERTISSEMENT:** Évitez les éclaboussures. Les éclaboussures peuvent créer de l'électricité statique et sont extrêmement dangereuses. Réduisez la vitesse du moteur pour éviter les éclaboussures.
- ⚠ AVERTISSEMENT:** La vitesse du fluide doit être au maximum de 3 pieds / 0,9 mètre / seconde (7 gpm / 26,5 lpm dans un tuyau de 1"; et 4 gpm / 15 lpm dans un tuyau de ¾") afin de réduire le risque d'électricité statique. Réduisez la vitesse du moteur afin de réduire ainsi la vitesse du fluide.
- 5. Avant utilisation, assurez-vous que les matériaux de la pompe et des accessoires (tuyau, ajustage, débitmètre, etc.) sont compatibles avec le fluide et que la température maximale n'est pas dépassée.

PUMP SPECIFICATIONS	
	MODEL PFS
Outer Tube Diameter	2" (51 mm)
Discharge Type	1" hose barb (or optional 1" MNPT, 1" FNPT, or 1" tri-clamp)
Max. Specific Gravity	1.83
Max. Viscosity	2000 cP
Min./ Max. Fluid Temperature	-20°F with FKM or buna o-rings (5° F with Perlast o-rings) Min. / 220° F Max.
	-4° C with FKM or buna o-rings (21° C) Min. / 105° C Max.
Wetted Materials	316 Stainless Steel, FKM (optional FFKM or buna-FDA), PTFE, ETFE

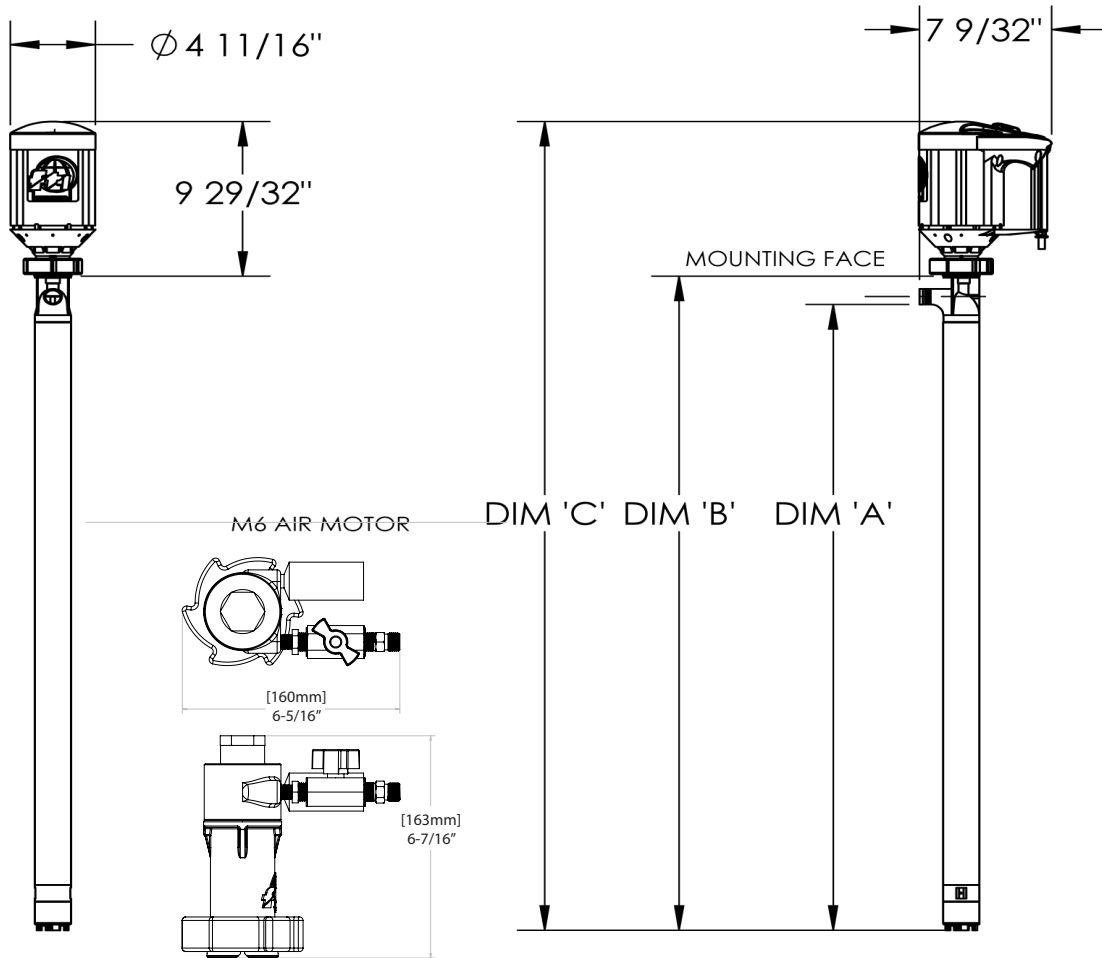

MODEL	DIM 'A' (IN.)	DIM 'A' (MM)	DIM 'B' (IN.)	DIM 'B' (MM)	DIM 'C' (IN.)	DIM 'C' (MM)
PFS-27	27	686	29	737	38-29/32	988
PFS-40	40	1016	42	1067	51-29/32	1318
PFS-48	48	1219	50	1270	59-29/32	1522
PFS-54	54	1372	56	1422	65-29/32	1674
PFS-60	60	1524	62	1575	71-29/32	1826
PFS-72	72	1829	74	1880	83-29/32	2131

Installation, Operation, & Maintenance Instructions

Installation

1. Remove the drum pump and motor from its packaging and inspect for shipping damage.
2. Turn the pump coupling to verify there is no binding. Verify the housing cover (item 16) is on tight (it has a left hand thread).
3. Adjust the coupling so that the empty slots in the insert are at 3 and 9 o'clock with the pump discharge at 12 o'clock.
4. Install the motor according to instructions in the appropriate motor manual.
5. Attach 1" i.d. discharge hose and secure with hose clamp.
6. Install into the container.

Operation

1. Make sure the motor (electric or air) is properly installed on the pump tube and is in the off position. See motor instruction manual for installation instructions.
2. Insert the pump tube into the fluid to be dispensed and the hose into the container to be filled prior to starting the pump. Bung adapters are available to provide a tighter fit between the pump tube and bung opening of a standard drum. Check drum pump accessories at www.finishthompson.com or contact your local Finish Thompson distributor for bung adapter info.
3. Make sure the pump's discharge hose is properly secured before operating the motor. Torque Finish Thompson hose clamps to 25 in-lbs(2.8 N·m)
4. Begin pumping by turning the motor on and verifying that there are no leaks. If leaks are noticed immediately turn the motor off and check all discharge hose connections.

NEVER allow the pump to run dry.

Maintenance

Disassembly

1. Remove the housing cover (item 16) by turning it clockwise (left hand thread) while gripping the impeller housing (item 13).
2. Turn the impeller (item 15) counterclockwise (right-hand thread) while holding the coupling half (item 2) with the other hand to prevent the shaft from turning and remove it.
3. Remove the impeller housing (item 13) by gripping the intake tube and turning the housing clockwise (left hand thread).
4. Place a wooden board or rubber mat on the floor (to protect the threads on the bottom of the shaft) and gently tap the shaft (item 14) on it until the inner tube (item 9), shaft sleeve (item 10), and bottom bearing (item 3) drops out. Continue to tap the shaft until both bearings (item 3) are exposed at the top of the pump.
5. Pull the bearings and shaft out through the top of the pump.

Inspection

1. Check the housing cover (item 16), the impeller (item 15), and the impeller housing (item 13) for wear, rubbing, or damage from foreign objects. Replace if damaged.
Note: The double impeller design of this pump is dependant on the impeller working correctly.
Any damage to the impeller can cause pump failure.
2. Inspect the pump shaft (item 14) for wear in the bearing (item 11) and the lip seal (item 4) areas. Replace the shaft if needed.
3. Inspect the bottom bearing (item 11) for internal wear. Inspect all o-rings (items 8 &12) for nicks or chemical attack. Replace as needed.
4. Inspect the bearing assembly (item 3) for rust or corrosion.
5. If the bearing assembly needs to be replaced, unthread it from the shaft. Hold the bearing assembly by the half coupling. Turn the shaft counterclockwise (right hand thread) to loosen and remove. If corroded, then a penetrating fluid may be used on the threads to help loosen.
Note: Never reuse the lip seal.

Reassembly

1. Install new lip seal (item 4) into the pump head with the grooved side facing the bottom of the pump.
2. If bearing assembly is replaced -- thread the shaft (item 14) into the bearing assembly (item 3) with the longer threaded end. Carefully insert the shaft straight through the lip seal (to avoid seal damage) from the top and seat the bearing assembly (item 3) into the pump head.
3. If o-rings are replaced -- install 2 inner tube o-rings (item 8) in the grooves. Install the impeller housing o-ring (item 12) inside the top of the housing. Apply a small amount of Vaseline to the o-rings to aid in assembly.
4. With the pump on a bench, slide shaft liner (item 10) into the inner tube (item 9) assembly onto the shaft until it stops. Slide the shaft liner/inner tube/shaft assembly into the outer tube (item 7) using the shaft (item 14) as a guide.
5. Slide the impeller housing over the shaft, center the bottom of the lower inner tube into the counter bore in the top of the impeller housing, and push / thread into the intake tube bottom (left hand thread).
6. Gripping the coupling at the top of the pump, thread the impeller on (right hand thread). Install the housing cover (left hand thread). turn the coupling to verify there is no binding inside the pump.

PFS SPARE PARTS EXPLODED VIEW

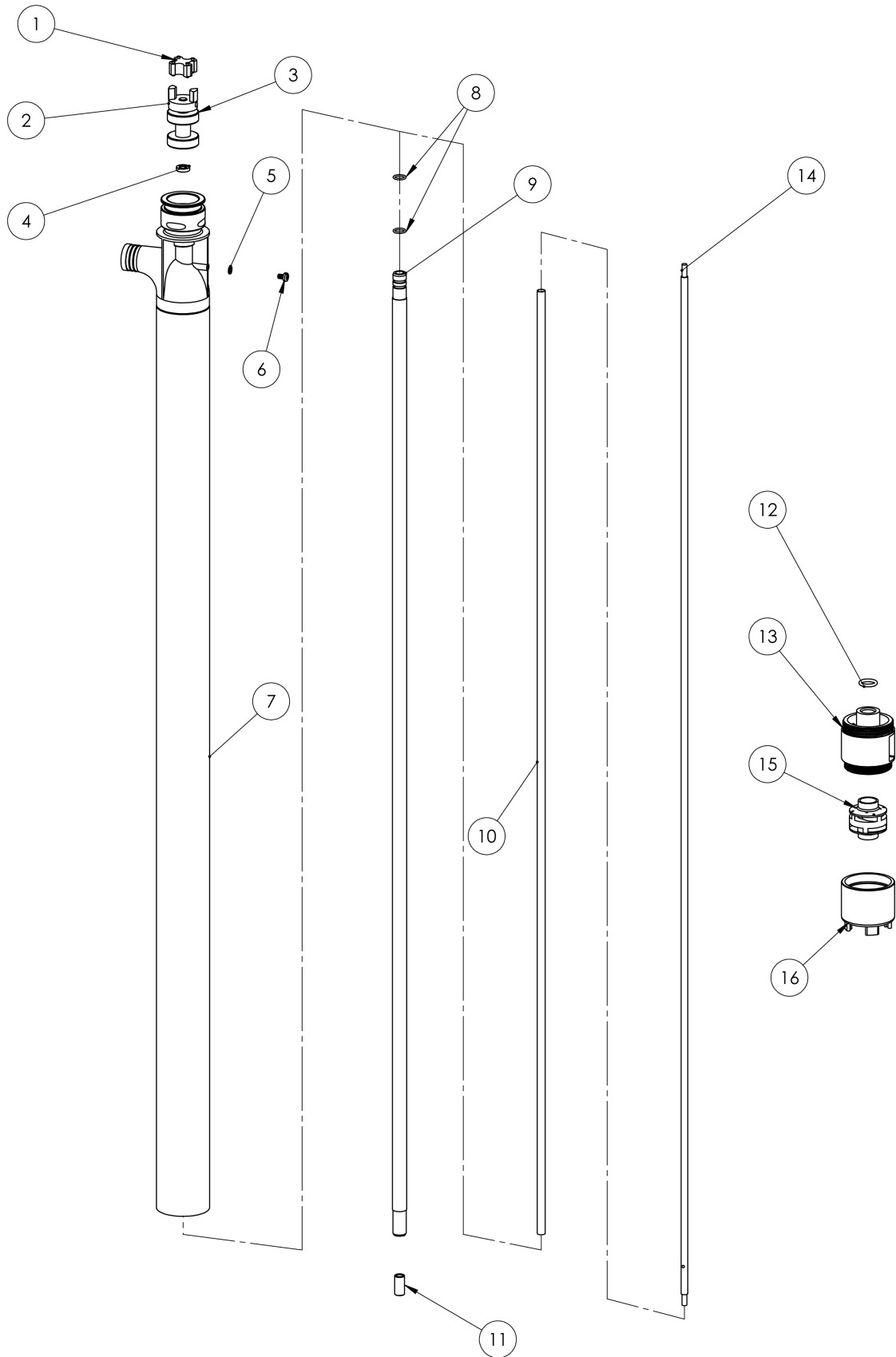

PUMP SPARE PARTS LIST

ITEM	QTY	DESCRIPTION	PART NUMBER
1	1	COUPLING INSERT	J100014
2	1	COUPLING HALF CAST ALUMINUM 1/4"-20 THREAD FOR S/N 211770 & UP	J100012-2
3*	1	BEARING ASSEMBLY (INCLUDES COUPLING HALF)	A101110
4*	1	LIP SEAL 1/4" FKM - STANDARD 1/4" PTFE - OPTIONAL	107592 107622
5	1	LOCK WASHER #8 BRASS	J100823
6	1	SCREW #8-32 X 1/4 BRASS PAN HEAD	J100822
7	1	INTAKE TUBE ASSEMBLY w/ 1" BARBED DISCHARGE (CONTACT FACTORY FOR ALL OTHER TYPES)	
		27" INTAKE TUBE - PFS-27	107619-1
		40" INTAKE TUBE - PFS-40	107619-2
		48" INTAKE TUBE - PFS-48	107619-3
		54" INTAKE TUBE - PFS-54	107619-7
		60" INTAKE TUBE - PFS-60	107619-4
		72" INTAKE TUBE - PFS-72	107619-5
		27" INTAKE TUBE - PFS-27-BTC	108204-1
		40" INTAKE TUBE - PFS-40-BTC	108204-2
		48" INTAKE TUBE - PFS-48-BTC	108204-3
		60" INTAKE TUBE - PFS-60-BTC	108204-4
		72" INTAKE TUBE - PFS-72-BTC	108204-5
		27" INTAKE TUBE - PFS-27-P & PFS-27-B	108206-1
		40" INTAKE TUBE - PFS-40-P & PFS-27-B	108206-2
		48" INTAKE TUBE - PFS-48-P & PFS-27-B	108206-3
		60" INTAKE TUBE - PFS-60-P & PFS-27-B	108206-4
		72" INTAKE TUBE - PFS-72-P & PFS-27-B	108206-5
		27" INTAKE TUBE - PFS-27-FT	108112-1
		40" INTAKE TUBE - PFS-40-FT	108112-2
		48" INTAKE TUBE - PFS-48-FT	108112-3
		60" INTAKE TUBE - PFS-60-FT	108112-4
		72" INTAKE TUBE - PFS-72-FT	108112-5
		27" INTAKE TUBE - PFS-27-MT	108114-1
		40" INTAKE TUBE - PFS-40-MT	108114-2
		48" INTAKE TUBE - PFS-48-MT	108114-3
		60" INTAKE TUBE - PFS-60-MT	108114-4
		72" INTAKE TUBE - PFS-72-MT	108114-5
8*	2	INNER TUBE O-RING FKM (STANDARD) EPDM FDA COMPLIANT BUNA FFKM	J100018 106798 108197 111511
9	1	STAINLESS STEEL INNER TUBE 27" MODELS 40" MODELS 48" MODELS 54" MODELS 60" MODELS 72" MODELS	107616-1 107616-2 107616-3 107616-7 107616-4 107616-5
10*	1	PTFE SHAFT SLEEVE 27" MODELS 40" MODELS 48" MODELS 54" MODELS 60" MODELS 72" MODELS	107615-1 107615-2 107615-3 107615-7 107615-4 107615-5
11*	1	BOTTOM BEARING STANDARD PTFE FDA-COMPLIANT PTFE	107618 108195

ITEM	QTY	DESCRIPTION	PART NUMBER
12*	1	IMPELLER HOUSING O-RING	
		FKM (STANDARD)	J100132
		EPDM	J100133
		FDA COMPLIANT BUNA	108198
		FFKM	111516
13†	1	IMPELLER HOUSING (sold as kit with Item 16)	
		Stainless steel	108130
14	1	SHAFT	
		27" MODELS	M100004-5
		40" MODELS	M100004-7
		48" MODELS	M100004-8
		54" MODELS	M100004-17
		60" MODELS	M100004-12
		72" MODELS	M100004-13
15	1	IMPELLER ASSEMBLY	
		ETFE (STANDARD)	A100002-3
		FDA COMPLIANT PURE ETFE	A100002-4
16†	1	HOUSING COVER (sold as kit with Item 13)	
			See Item 13

*Recommended Spare Parts

†If replacing either item number 13 or 16, you must order both to assure proper fit.

Note: Bearing assembly and FKM lip seal can be purchased as a kit using part number 108110.

DRUM PUMP TROUBLESHOOTING

General Notes:

- Do not pump liquids containing metallic particles or other foreign material.
- Always store the pump upright as used.
- Contact our Technical Service Department at 1-800-888-3743 or by email at techservice@finishthompson.com if you have any questions regarding product operation or repair.

No or Insufficient Discharge:

- Discharge spout is not trimmed
- Closed valve or nozzle
- System head higher than anticipated
- Viscosity or specific gravity too high
- Clogged pump tube
- Clogged or damaged impeller

Vibration/Noise:

- Missing or damaged coupling insert
- Damaged bearing assembly
- Viscosity or specific gravity too high
- Pump cavitation from improper discharge
- Pump or piping not properly secured
- Clogged or damaged impeller



FINISH THOMPSON INC.

Service 1-800-888-3743

P/N 108098 Rev. 9, 7/17/2023