

# MT, MTV & MXV Series Motors

## Operation & Parts Manual

For use with models M3T (p/n 110014), M5T (p/n 110015), M73, M74, M3TV, M5TV, M75, M76, M7TV, M8TV, M3XV, M5XV, M5XV-HT, M77, M78, M78-HT, M7XV, M8XV

P/N: 110062 R7



**FINISH THOMPSON INC.**

## EU Declaration of Conformity



Finish Thompson Inc. hereby declares that the following electrical equipment fully complies with the applicable health and safety requirements as specified by the EU Directives listed. The product may not be taken into service until it has been established that the driven Drum and Container Pump complies with the provisions of all relevant EU Directives. The complete product complies with the provisions of the EU Directive on machinery safety provided pumps manufactured by Finish Thompson Inc. are used.

This declaration is valid provided that the devices are fully assembled and no modifications are made to these devices.

### Type of Device:

Electric Motors for Driving Drum and Container Pumps

### Models:

M5T, M74, M5TV, M76, M8TV, M5XV, M5XV-HT, M78, M78-HT M8XV

### EU Directives:

Low Voltage Equipment (2014/35/EU)  
Electromagnetic Compatibility (2014/30/EU)

### Applied Harmonized Standards:

EN 60335-1:2012+A11:2014+A13:2017	EN 62233:2008	EN IEC 55014-2:2021
+A1:2019+A2:2019+A14:2019	EN 60529:1992+A2:2013	EN IEC 61000-3-2:2019+A1:2021
EN 60335-2-41:2003+A1:2004+A2:2010	EN IEC 55014-1:2021	EN 61000-3-3:2013+A1:2019

### Manufacturer:

Finish Thompson Inc.  
921 Greengarden Road  
Erie, Pennsylvania 16501-1591 U.S.A

Signed,



President

October 29, 2021

Person(s) Authorized to Compile Technical File: Finish Thompson GmbH  
Otto-Hahn-Strasse 16  
Maintal, D-63477 DEU  
Telephone: 49 (0)6181-90878-0



**FINISH THOMPSON INC.**

921 Greengarden Road • Erie PA USA  
(800) 934-9384 • (814) 455-4478 fax  
www.finishthompson.com

## EU Declaration of Conformity



Finish Thompson Inc. hereby declares that the following machines fully comply with the applicable health and safety requirements as specified by the EU Directives listed. This declaration is valid provided that the devices are fully assembled and no modifications are made to these machines. Revisions to the device are covered within FTZU Supplementary Certificate No. 2.

### **Type of Device:**

Electric Motors for Driving Drum and Container Pumps

### **Models:**

M5XV, M5XV-HT, M78, M78-HT, M8XV

### **EU Directives:**

Equipment and protective systems intended for use in potentially explosive atmospheres (2014/34/EU)

### **EU-Type Examination**

Physical Technical Testing Institute 1026  
Ostrava-Radvanice  
FTZU 14 ATEX 0200X

### **Product Quality Assurance Notification:**

Physical Technical Testing Institute 1026  
Ostrava-Radanice  
FTZU 08 ATEX Q 003

### **Applied Harmonized Standards:**

EN IEC 60079-0:2018    EN 60079-1:2014    EN 60079-11:2012

### **Manufacturer:**

Finish Thompson Inc.  
921 Greengarden Road  
Erie, Pennsylvania 16501-1591 U.S.A

Signed,

President

October 29, 2021

Person(s) Authorized to Compile Technical File: Finish Thompson GmbH  
Otto-Hahn-Strasse 16  
Maintal, D-63477 DEU  
Telephone: 49 (0)6181-90878-0

## Introduction

This manual pertains to the MT, MTV & MXV Series drum pump motors. Finish Thompson, Inc. thanks you for choosing our products. We believe the use of our products will be fully satisfactory. When properly installed and operated, your Finish Thompson motor and pump will provide long, trouble-free service; therefore please read this manual carefully before carrying out any operations on the pump-motor unit. Any use other than that described herein is considered incorrect and; consequently, Finish Thompson, Inc. shall not be held responsible for any damages to people or things. In case of doubt or enquiries, please apply to our Technical Service department directly at the following address:

Finish Thompson, Inc.  
921 Greengarden Rd.  
Erie, PA 16501 U.S.A.  
Tel. 1-814-455-4478  
Fax 1-814-455-8518  
[www.finishthompson.com](http://www.finishthompson.com)  
[fti@finishthompson.com](mailto:fti@finishthompson.com)

## Index

Introduction .....	4
General Terms & Conditions, Warranty .....	5
Warranty Registration .....	5
Safety .....	6-8
Installation .....	9-10
Grounding of ATEX/Haz Loc Motors .....	10
Operation .....	10-11
Motor Specifications .....	12
Motor Identification .....	13
TEFC Motors Spare Parts .....	14
Explosion Proof Motors Spare Parts .....	15

## **WARRANTY, GENERAL TERMS & CONDITIONS**

Finish Thompson, Inc (manufacturer) warrants this pump product to be free of defects in materials and workmanship for a period of **one year** from date of purchase by original purchaser. If a warranted defect, which is determined by manufacturer's inspection, occurs within this period, it will be repaired or replaced at the manufacturer's option, provided (1) the product is submitted with proof of purchase date and (2) transportation charges are prepaid to the manufacturer. Liability under this warranty is expressly limited to repairing or replacing the product or parts thereof and is in lieu of any other warranties, either expressed or implied. This warranty does not apply to normal wear of the product or components. This warranty does not apply to products or parts broken due to, in whole or in part, accident, overload, abuse, chemical attack, tampering, or alteration. The warranty does not apply to any other equipment used or purchased in combination with this product. The manufacturer accepts no responsibility for product damage or personal injuries sustained when the product is modified in any way. If this warranty does not apply, the purchaser shall bear all cost for labor, material and transportation.

Manufacturer shall not be liable for incidental or consequential damages including, but not limited to, process down time, transportation costs, costs associated with replacement or substitution products, labor costs, product installation or removal costs, or loss of profit. In any and all events, manufacturer's liability shall not exceed the purchase price of the product and/or accessories.

## **WARRANTY REGISTRATION**

Thank you for your purchase of this quality Finish Thompson product. Be sure to take a minute to register your pump at [Finishthompson.com/warranty](http://Finishthompson.com/warranty). Simply provide the model number, serial number and a few other pieces of information.

# SAFETY

## 1. Introduction

This manual contains all the information needed for the correct installation, use, and maintenance of your new Finish Thompson motor. It should be read and understood by all the personnel involved in installation, operating, and servicing of the pump before it is started.

## 2. Operator Qualification and Training

The personnel in charge of the installation, operation and maintenance of the pump unit we produce must be qualified and able to perform the operations described in this manual. Finish Thompson Inc. shall not be held responsible for the training level of personnel and for the fact that they are not fully aware of the contents of this manual.

## 3. Safety Instructions



**FOR YOUR OWN SAFETY:**

**BEFORE UNDERTAKING ANY SERVICE OPERATION ON YOUR MOTOR OR PUMP, PLEASE MAKE SURE TO WEAR THE PROPER PROTECTIVE GEAR.**



**DANGER: POWER SUPPLY**

**NEVER** perform any maintenance operation on the motor while it is running or before it has been disconnected from the power supply. Avoid any possible hazard that might be caused by electric power.

**ALWAYS** use an ATEX Zone 1 approved plug and receptacle for ATEX motor models.

**ALWAYS** use a UL/CSA Class I Division 1 Group D approved plug and receptacle for Hazardous Location motor models.

**NEVER** operate ATEX rated or Haz Loc rated motors outside their rated ambient temperature range.

<b>ATEX &amp; Haz Loc Rated Motors</b>	<b>Rated Ambient Temperature</b>
M3XV, M5XV, M77, M78, M7XV, M8XV	-4°F (-20°C) to 104°F (40°C)
M5XV-HT, M78-HT	-4°F (-20°C) to 140°F (60°C)

**Warning:** Explosion Hazard - Do not replace the cord on Explosion proof motor models. Replacing the cord will invalidate the safety of the equipment. Return the motor back to the manufacturer for cord replacement. Do not open or repair the flame-proof joints of Explosion proof motors. Contact the manufacturer for cord, fuse, and circuit board replacement.

**Warning:** Clean motor only with a damp cloth to avoid electrostatic discharge.



**GENERAL DANGER**

**NEVER** use a plastic pump or an open, splash-proof, TEFC or non-ATEX motor when pumping or mixing flammable or combustible material. **ALWAYS** use and store the pump and motor in an upright position.

**ALWAYS** check the electrical specifications on the motor data plate and make sure they correspond to the power supply to which it will be connected.

**ALWAYS** place motor in the OFF position prior to connecting the power source.

**NEVER** immerse the motor in liquid.



Static sparking can cause an explosion. **Always** follow NFPA 77 and CLC/TR 60079-32-1 guidelines for control of static electricity and proper grounding methods when using ATEX and Hazardous Location motor models. When operating in a hazardous area or pumping a hazardous fluid, the motor and entire pump system must be grounded to prevent static discharge using a Static Protection Kit.

## 4. Noise Level

At normal operating conditions, MT, MTV and MXV motors produce a sound level equal or less than 81 dBA at a distance of three feet (~ one meter).

## 5. Modifications and Spare Parts

Any changes concerning the service of the motor as originally purchased can be executed only after written approval from Finish Thompson Inc. It is recommended to use only genuine Finish Thompson Inc. spare parts and approved accessories. The use of non-original spare parts or non-approved accessories will void warranty and removes any responsibility on our behalf for any damage caused to people or things.

# Sécurité

## 1. Introduction

Ce manuel donne toutes les instructions nécessaires pour assurer l'installation, l'utilisation et l'entretien adéquats du moteur de pompe Finish Thompson. Ces instructions doivent être lues et comprises par tout le personnel participant à l'installation, à l'utilis

## 2. Qualifications et formation des opérateurs

Le personnel en charge de l'installation, de l'utilisation et de l'entretien de la pompe et de son moteur doit être qualifié et capable d'effectuer les tâches décrites dans ce manuel. Finish Thompson Inc. n'est pas responsable du niveau de formation du personnel et du fait qu'ils n'aient pas pris entièrement connaissance du contenu de ce manuel.

## 3. Consignes de sécurité

### **POUR VOTRE SÉCURITÉ**

AVANT d'utiliser ou de faire l'entretien de votre pompe, s'assurer de porter les vêtements protecteurs adéquats, les protections oculaires (pour les yeux) et de suivre les procédures de sécurité standard pour manipuler les matières corrosives ou danger e uses pour la santé.

### **DANGERS GÉNÉRAUX**

**NE JAMAIS** utiliser de pompe en plastique ni de moteur ouvert, étanche aux éclaboussures, de type TEFC ou non conforme à la norme ATEX, pour pomper ou mélanger des matières inflammables ou combustibles.

 **TOUJOURS** utiliser et remiser la pompe et le moteur en position verticale.

### **DANGER : ALIMENTATION ÉLECTRIQUE**

**NE JAMAIS** effectuer aucune tâche d'entretien sur le moteur lorsqu'il est en marche, ou avant de le débrancher de son alimentation électrique. Éviter toute condition dangereuse en rapport avec l'alimentation électrique.

 **TOUJOURS** vérifier les spécifications électriques sur la plaque signalétique du moteur et s'assurer qu'elles correspondent à l'alimentation électrique à laquelle il est raccordé. TOUJOURS mettre le moteur en position d'arrêt («OFF») avant de le raccorder à l'alimentation électrique.

 **NE JAMAIS** immerger le moteur dans un liquide.

 **TOUJOURS** utiliser une prise et une prise homologuées ATEX Zone 1 pour les modèles de moteurs ATEX.

 **TOUJOURS** utiliser une prise et un réceptacle homologués UL / CSA Classe I Division 1 Groupe D pour les modèles de moteurs à emplacement dangereux.

**NE JAMAIS** Ne faites jamais fonctionner les moteurs en dehors de leur température ambiante nominale.

Moteurs classés ATEX et Haz Loc	Température ambiante nominale
M3XV, M5XV, M77, M78, M7XV, M8XV	-4°F (-20°C) to 104°F (40°C)
M5XV-HT, M78-HT	-4°F (-20°C) to 140°F (60°C)

## 4. Niveau de bruit

En conditions normales d'utilisation, les moteurs électriques MTV et MXV génèrent un niveau de bruit égal ou inférieur à 81 dBA à une distance de 3 pieds (env. 1 mètre).

## 5. Modifications et pièces de rechange

Toute modification concernant l'entretien du moteur/pompe, tels qu'achetés initialement, peut être exécutée seulement après en avoir obtenu l'autorisation écrite de Finish Thompson Inc. On demande d'utiliser seulement les pièces de rechange originales de Finish Thompson Inc. et les accessoires approuvés. Le fait de ne pas utiliser les pièces de rechange originales de Finish Thompson Inc. ou les accessoires approuvés annulera la garantie et dégagea le fabricant de toute responsabilité liée aux blessures ou dommages matériels.

## IMPORTANT SAFETY INFORMATION FOR PUMPING FLAMMABLE OR HAZARDOUS SUBSTANCES

Read these instructions before operating the pump and motor equipment. The manufacturer will not be responsible for any damage to property or to persons caused by improper use of the equipment.

- ⚠ WARNING:** It is the responsibility of the user to operate the pump in conformance with OSHA rules for dispensing liquids. Pump containers should be grounded when using with flammable or combustible liquids to avoid static electricity.
- 1. Use only an explosion-proof rated electric or non-electric (air) motors on stainless steel pump tubes with a Static Protection Kit when transferring flammable or combustible liquids.
- ⚠ WARNING:** Never use an open, splash-proof, TEFC, battery-operated or non-explosion-proof rated motor or a plastic pump tube when transferring flammable or combustible liquids.
- 2. When operating a drum pump (especially when pumping flammable, combustible or hazardous liquids) follow all electrical and safety codes.
  - a) In the United States: the United States Occupational Safety and Health Act (OSHA), most recent National Electrical Code (NEC), National Fire Protection, Inc. (NFPA) Code 30 (Flammable and Combustible Code), NFPA 77 (Static Electricity), NFPA 251 (Standard Method of fire Test of Building Construction), NFPA 704 (Identification of the Fire Hazards of Materials), and other NFPA codes, local codes and ordinances.
  - b) Outside the United States: the ATEX equipment directive 2014/34/EU where applicable, the ATEX workplace 99/92/EC directive where applicable, in addition the precautions of the U.S. codes listed herein and all other local codes and ordinances.
- 3. Pumping hazardous, flammable, or combustible liquids should only be done in buildings, rooms, or areas suited for this purpose. (See NFPA 30, NFPA 78, NFPA 80, NFPA 251, NFPA 704, other suitable NFPA codes, OSHA, ATEX workplace 99/92/EC directive insurance companies, and other local codes and ordinances.)
- 4. When filling cans, drums, etc. with combustible or flammable liquids, both container pumping from and container pumping to, should be bonded and grounded to dissipate possible accumulations of static electricity, and minimize sparks caused by static electricity (refer to NFPA 77 and CLC/TR 60079-32-1 for specific details).
- ⚠ WARNING:** Avoid splashing. Splash filling can create static electricity and is extremely hazardous. Reduce motor speed to prevent splashing.
- ⚠ WARNING:** Fluid velocity must be 3 feet/.9 meter/second maximum (7 gpm/26.5 lpm in 1" hose and 4 gpm/15 lpm in ¾" hose) to reduce risk of static electricity. Reduce motor speed to reduce the fluid velocity.
- 5. Before using, confirm that the pump and any accessories (hose, nozzle, flow meter, etc.) materials of construction are suitable for the material to be pumped and that the maximum temperature is not exceeded.

## INFORMATIONS IMPORTANTES SUR LA SÉCURITÉ DURANT LE POMPAGE DE SUBSTANCES INFLAMMABLES OU DANGEREUSES

Veillez lire attentivement ces instructions avant d'utiliser la pompe et l'équipement du moteur. Le fabricant ne sera pas tenu responsable des dommages matériels ou corporels causés par une utilisation inappropriée de l'équipement.

- ⚠ AVERTISSEMENT:** Il est de la responsabilité de l'utilisateur de faire fonctionner la pompe conformément aux règles OSHA (Santé et Sécurité au Travail) relatives à la distribution de liquides. Les conteneurs de pompes doivent être électriquement mis à la terre lors de l'utilisation de liquides inflammables ou combustibles afin d'éviter toute électricité statique.
- 1. Lors du transfert de liquides inflammables ou combustibles, utilisez uniquement des moteurs électriques ou non électriques (pneumatiques) antidéflagrants sur des tubes de pompe en acier inoxydable dotés d'un dispositif de protection antistatique.
- ⚠ AVERTISSEMENT:** N'utilisez jamais de moteur ouvert, à l'épreuve des éclaboussures, TEFC, alimenté par piles ou non antidéflagrant, ni un tube de pompe en plastique lors du transfert de liquides inflammables ou combustibles.
- 2. Lors de l'utilisation d'une pompe à tambour (en particulier lors du pompage de liquides inflammables, combustibles ou dangereux), respectez tous les codes électriques et les codes de sécurité.
  - a) Aux États-Unis : Loi américaine sur la sécurité et la santé au travail (OSHA); le code national de l'électricité (NEC) le plus récent; le code 30 de la NFPA (code d'inflammabilité et de produits combustibles); le code NFPA 77 (électricité statique); le code NFPA 251 (Méthode standard de test d'incendie de la construction de bâtiments); le code NFPA 704 (Identification des risques d'incendie des matériaux) et autres codes et règlements de la NFPA.
  - b) En dehors des États-Unis : La directive sur les équipements ATEX 2014/34 / EU, le cas échéant, la directive ATEX sur le lieu de travail 99/92 /EC, le cas échéant, ainsi que les précautions des codes des États-Unis énumérés dans la présente et de tous les autres codes, lois et règlements locaux.
- 3. Le pompage de liquides dangereux, inflammables ou combustibles ne doit être effectué que dans des bâtiments, des pièces ou des zones adaptées à cet usage. (Voir NFPA 30, NFPA 78, NFPA 80, NFPA 251, NFPA 704, autres codes NFPA appropriés, OSHA, les directives des compagnies d'assurance ATEX 99/92 /CE, et autres codes, lois et règlements locaux.)
- 4. Lors du remplissage de bidons, fûts, etc. avec des liquides combustibles ou inflammables, les conteneurs d'où le liquide est pompé et le conteneur recevant le liquide doivent être reliés et mis à la terre pour éviter toute accumulation éventuelle d'électricité statique et minimiser ainsi les étincelles causées par l'électricité statique (voir NFPA 77). et CLC / TR 60079-32-1 pour des détails spécifiques).
- ⚠ AVERTISSEMENT:** Évitez les éclaboussures. Les éclaboussures peuvent créer de l'électricité statique et sont extrêmement dangereuses. Réduisez la vitesse du moteur pour éviter les éclaboussures.
- ⚠ AVERTISSEMENT:** La vitesse du fluide doit être au maximum de 3 pieds / 0,9 mètre / seconde (7 gpm / 26,5 lpm dans un tuyau de 1"; et 4 gpm / 15 lpm dans un tuyau de ¾") afin de réduire le risque d'électricité statique. Réduisez la vitesse du moteur afin de réduire ainsi la vitesse du fluide.
- 5. Avant utilisation, assurez-vous que les matériaux de la pompe et des accessoires (tuyau, ajustage, débitmètre, etc.) sont compatibles avec le fluide et que la température maximale n'est pas dépassée.



## INSTALLATION

1. Unpack motor from carton. Check for shipping damage. If damage is detected, save the packaging and notify the carrier immediately.
2. Loosen the nut on the motor housing by turning it counterclockwise (as viewed from the bottom of the motor). Note that the nut remains on the motor even when loosened. See figure 1.
3. Looking into the bottom/drive-end of the motor, align the coupling half with the coupling half orientation of the pump. Aligning the coupling half with two of the slots in the motor adapter sleeve is recommended to provide a reference point. See figures 2 & 3.
4. Make sure that the rubber coupling insert (provided with the pump) is properly installed in the pump coupling half.
5. With the motor coupling half properly aligned, firmly push the motor down over the pump head until fully engaged. See figure 3.
6. The motor isn't fully coupled unless the bottom of the motor and the top of the pump are completely flush. See figure 4.

**⚠ Warning:** Do not position the motor handle and cord over and in front of the pump discharge. Position it in line with the discharge or at 90° to the discharge.

7. Manually tighten the nut by turning it clockwise until secure. See figure 5.

**Note:** Do not use hand tools to tighten the nut as this may cause damage to the motor casing.



Figure 1



Figure 2



Figure 3



Figure 4

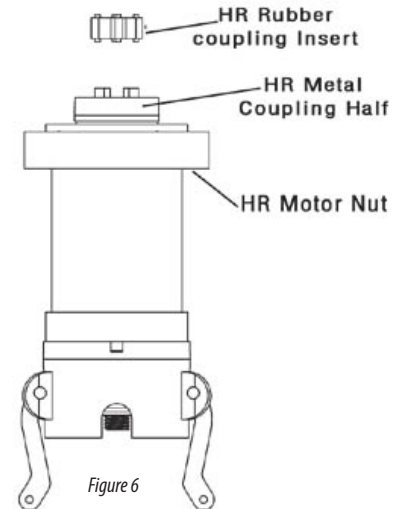

Figure 5

## INSTALLATION

### HVDP-HR Drum Pump Tubes

1. Unpack motor from carton. Check for shipping damage. If damage is detected, save the packaging and notify the carrier immediately.
2. Locate the rubber coupling insert that was separately shipped in a plastic bag (see Figure 6).
3. Install the rubber coupling insert onto the metal coupling half located on top of the HR drive assembly.
4. Find the metal coupling half located inside the HR motor. Align this coupling with rubber insert installed in the second step of these instructions.
5. Slide the HR motor onto the HR drive assembly.
6. Hand tighten the motor nut onto the threaded nose of the HR motor.
7. HVDP-HR REMOVAL: To remove the HR motor, reverse HR motor installation instructions found in this section.



## INSTALLATION

### Grounding of ATEX & Haz Loc Motors (Models M3XV, M77, M7XV, M5XV, M78, & M8XV)

When operating in a hazardous area or pumping a hazardous fluid, the motor and entire pump system must be grounded to prevent static discharge using a static protection kit.

- Unscrew the #10-32 wing nut from the side of the motor housing, and attach a grounding wire with a #10 ring terminal. Screw the wing nut back on and tighten firmly by hand. Ground the motor, pump, and all containers according to the Finish Thompson "Static Protection Kit" Assembly Instructions.
- Follow the safety instructions for the appropriate pump.



## OPERATION

The MT series motors utilize an ON/OFF rocker switch for simple ON/OFF operation, and a manual push-to reset circuit breaker. In the event of an over-current trip, the motor should be turned off and the circuit breaker can be reset. If the motor thermally trips off and the circuit breaker is not tripped, it can be reset by turning off the motor and allowing it to cool.

MTV & MXV Series motors utilize an electronic motor controller and membrane keypad to provide precise speed control and superior motor protection. An electronic circuit board within the housing controls the motor's speed, overload protection, motor temperature, and electronics' temperature. The keypad incorporates two colored LED lights to provide feedback to the user.

Insert the pump tube into the fluid to be dispensed and the discharge hose into the container to be filled. Make sure the pump's discharge hose is properly secured prior to operating the motor. When the unit is plugged into a power outlet, the "Green" LED will blink indicating it is in "Standby mode", meaning that power is provided, but the motor is "Off". Pressing the "Power" key will turn the motor "On" and it will begin to ramp up to speed. The "Green" LED will

change from blinking to solid indicating the motor is “On”. Pressing the “Down” or “Up” keys will change the 10 available motor speeds, and can also be held in for quicker adjustment. Pressing the “Power” Key will switch the motor “Off” and the “Green” LED will again blink indicating the unit is in “Standby” mode. When the “Power” key is pressed again, the motor will ramp up to the previously set speed. When the unit’s power is disconnected, the stored speed is set back to the default speed.

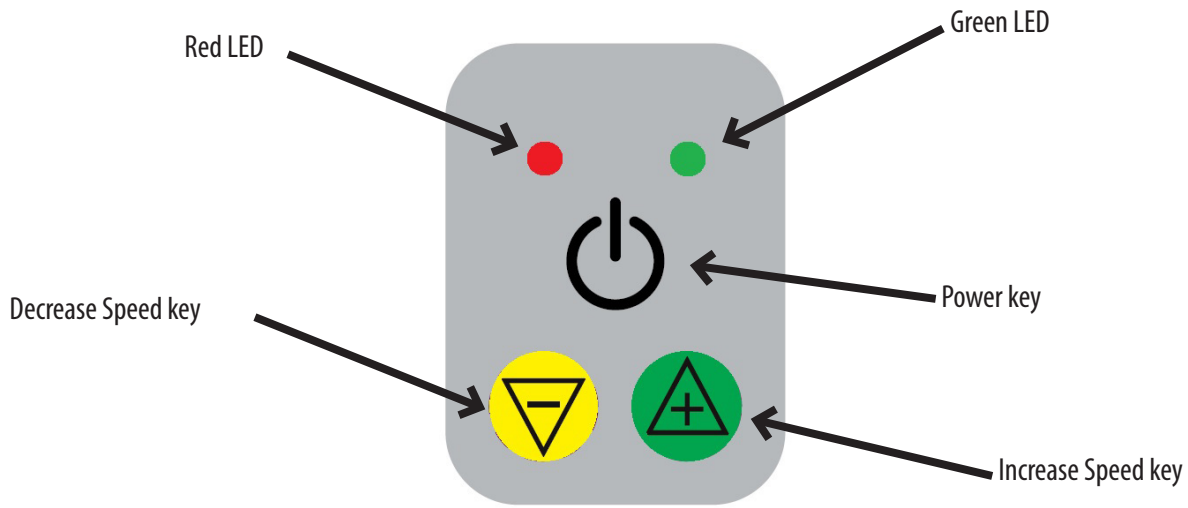

Figure 7 - Keypad

The “Red” LED indicates a motor fault. When the motor faults, it will turn off into “Standby” mode with the “Green” LED blinking. The blink pattern of the “Red” LED will indicate the fault type:

Red LED Blink Pattern	Fault Type	Solution
Solid Red	Over Current	Reduce motor speed. Ensure fluid viscosity is within pump limits.
Blinking Red	Over Temperature	Allow motor to cool. Reduce motor speed. Ensure fluid viscosity is within pump limits. If motor is cool, brushes may have reached end of life.



Press the “Power” key to reset the fault and the motor will turn “On”. The motor will not turn “On” until it has cooled to an acceptable level.



It may be necessary to operate the pump at a slower speed for high viscosity fluids. Contact factory for troubleshooting tips. At slower speeds, ensure the motor is running to prevent it from overheating, of which can reduce the motor’s life. Unplug the unit when not in use.





Depending on the application, motor brush life is approximately 200-300 hours. Contact Finish Thompson for brush replacement kits. Models M3XV, M5XV, M77, M78, M7XV. M8XV must be sent to Finish Thompson for factory brush replacement.

MTV & MXV Series motors can be controlled with batch control flow meters. Contact Finish Thompson for more information.

Models w/ keypads contain a replaceable fuse on the circuit board which may need replaced in the event of a power surge. The fuse may be replaced on models a M3TV, M75, M7TV, M5TV, M76, and M8TV with a 250V, 150mA medium blow fuse such as an Eaton Bussman part # BK/GMC-150-R. Motor models with a rocker switch do not contain a fuse. Consult the factory for fuse replacement of X motor models.

Motor Specifications							
Model	M3T		M73		M5T		M74
Part Number	110014		110016		110015		110017
Rated Voltage	115V			230V			
Hertz	60 Hz			50/60 Hz			
Input Watts	1000			1010			
Output Watts	680			680			
Certificates or Approvals							
Plug Type	NEMA 5-15P			CEE 7/7			
RPMs	12,000 RPM						
Duty Cycle	Continuous Duty						
Enclosure	TEFC			IP55 (TEFC)			
Maximum Specific Gravity	1.8	1.4	1.8	1.8	1.4	1.8	
Max Viscosity	1,000 cP	200 cP	10,000 Cp	1,000 cP	200 cP	10,000 cP	
Applicable Pump Models	PF	TB	HVDP-HR	PF	TB	HVDP-HR	

Motor Specifications											
Model	M3TV		M75		M7TV		M3XV		M77		M7XV
Part Number	110018		110020		110022		110024		110026		110028
Rated Voltage	115V										
Hertz	60 Hz										
Input Watts	1000			450			1000			450	
Output Watts	680			250			680			250	
Certificates or Approvals											
	N/A					Haz Loc, CLASS 1, DIVISION 1, GROUP D, T4					
Plug Type	NEMA 5-15P					None					
RPMs	12,000 RPM			0-6,000 RPM			12,000 RPM			0-6,000 RPM	
Duty Cycle	Continuous Duty										
Enclosure	TEFC										
Max. Specific Gravity	1.8	1.4	1.8	1.8	1.8	1.4	1.8	1.8	1.8	1.8	
Max. Viscosity	2,000 cP	200 cP	20,000 cP	500 cP	1,000 cP	2,000 cP	200 cP	20,000 cP	500 cP	1,000 cP	
Applicable Pump Models	PF	TB	HVDP-HR	TT	TM	PF	TB	HVDP-HR	TT	TM	

Motor Specifications														
Model	M5TV		M76		M8TV		M5XV		M78		M8XV		M5XV-HT	M78-HT
Part Number	110019		110021		110023		110025		110027		110029		110871	110872
Rated Voltage	230V													
Hertz	50/60 Hz													
Input Watts	1000			450			1010			450			1010	
Output Watts	680			250			680			250			680	
Certificates or Approvals						 II 2G Ex db ib IIB T5 Gb 					 II 2G Ex db ib IIB T4 Gb 			
	N/A													
Max. Ambient Temperature							104°F (40°C)			140°F (60°C)				
Plug Type	CEE 7/7						None							
RPMs	12,000 RPM			0-6,000 RPM			12,000 RPM			0-6,000 RPM			0-12,000 RPM	
Duty Cycle	Continuous Duty													
Enclosure	IP55 (TEFC)													
Max. Specific Gravity	1.8	1.4	1.8	1.8	1.8	1.4	1.8	1.8	1.8	1.8	1.4	1.8		
Max. Viscosity	2,000 cP	200 cP	20,000 cP	500 cP	1,000 cP	2,000 cP	200 cP	20,000 cP	500 cP	1,000 cP	2000 cP	200 cP	20,000 cP	
Applicable Pump Models	PF	TB	HVDP-HR	TT	TM	PF	TB	HVDP-HR	TT	TM	PF	TB	HVDP-HR	

**MOTOR IDENTIFICATION  
(SAMPLE LABEL)**



**FINISH THOMPSON INC.**

921 Greengarden Road • Erie, PA 16501-1591 U.S.A.  
Ph 814-455-4478 • Fax 814-455-8518  
Email [fti@finishthompson.com](mailto:fti@finishthompson.com) • [www.finishthompson.com](http://www.finishthompson.com)



**MODEL: M3TV**  
**PART NO: 110018**  
**SERIAL NO: 123456 D20**  
**115 VAC, 60 HZ, 9.1 AMPS**  
**INPUT: 1000 W, OUTPUT: 680 W**  
**0-12,000 RPM, CLASS F INS., CODE F.**  
**TEFC ENCLOSURE (IP55)**  
**THERMALLY PROTECTED**

**DATE OF MFG: 04/02/2020**



**CERTIFIED  
ELECTRICAL SAFETY**



LR1566

**MADE IN THE USA**



**WARNING!** THIS EQUIPMENT IS NOT EXPLOSION PROOF

**AVERTISSEMENT!** CET ÉQUIPEMENT N'EST PAS ANTIDÉFLAGRANT

- DO NOT use this equipment in or near flammable or combustible liquids!
- DO NOT submerge this motor in fluid!
- DO wear eye and skin protection.
- DO read proper operation and safety precautions in instruction manual.

**CAUTION:** SEE INSTRUCTION MANUAL BEFORE SERVICING.

**ATTENTION:** Voir le mode d'emploi pour les avertissements.



**DO NOT STORE  
UPSIDE DOWN**

## TEFC MOTOR PARTS

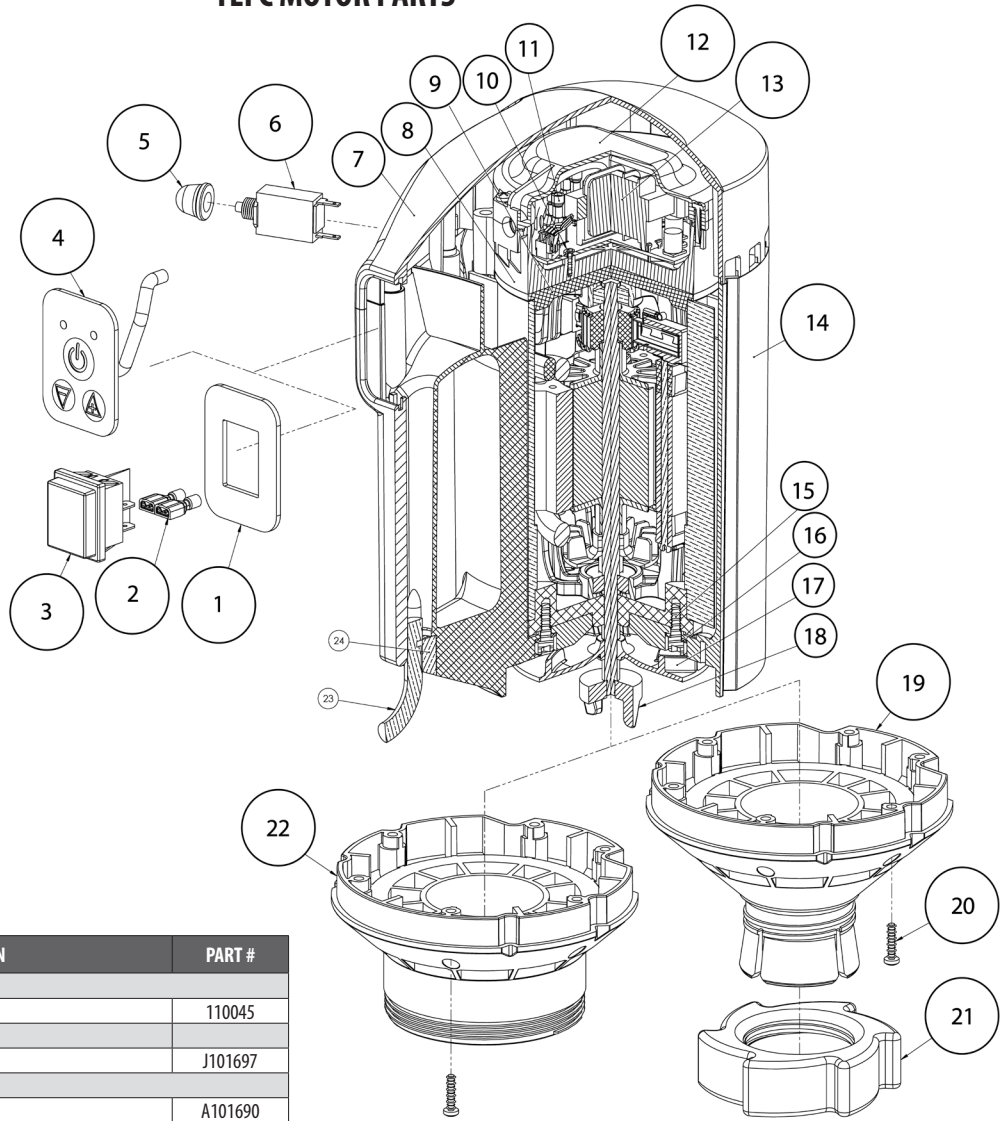

ITEM	QTY	DESCRIPTION	PART #
1	1	<b>Switch Insert</b> M3T, M5T, M73, M74	110045
2	3	<b>Disconnect</b> M3T, M5T, M73, M74	J101697
3	1	<b>Switch On/Off w/Cover</b> M3T, M5T, M73, M74	A101690
4	1	<b>Keypad</b> M3TV, M5TV, M75, M76, M7TV, M8TV	110040
5	1	<b>Cover, Circuit Breaker</b> M3T, M5T, M73, M74	J100789
6	1	<b>Circuit Breaker, 8.5 Amps</b> 8.5 amps - M3T, M73 4.5 amps - M5T, M74	110044 110044-1
7	1	<b>Cover</b> M3TV, M5TV, M75, M76, M7TV, M8TV (for keypad) M3T, M5T, M73, M74 (for rocker switch)	110031 110031-1
8	1	<b>TEFC Enclosure</b> All Models	110052
9	1	<b>Heat Sink Plate</b> All Models	110206
10	3	<b>Screw PPH</b> M3TV, M5TV, M75, M76, M7TV, M8TV	J103715
11	6	<b>Female Quick Disconnect</b> M3TV, M75, M7TV	110047
	5	M5TV, M76, M8TV	110047
12	1	<b>TEFC Enclosure Cover</b> All Models	110046
13	1	<b>Printed Circuit Board, TEFC</b> M3TV, M5TV, M75, M76, M7TV, M8TV	110039
14	1	<b>Canister</b> All Models	110032
15	4	<b>Cap Screw Socket Head</b> All Models	J102643
16	4	<b>Washer, Lock</b> All Models	J100672
17	1	<b>Fan</b> All Models	110034

ITEM	QTY	DESCRIPTION	PART #
18	1	<b>Coupling Half, Threaded</b> All Models	J100012-2
19*	1	<b>Bottom Mount</b> M3T, M5T, M3TV, M5TV, M7TV, M8TV	110035
20	19	<b>Screw PPH</b> All Models	J101020
21*	1	<b>Collet Nut</b> M3T, M5T, M3TV, M5TV, M7TV, M8TV	106541
22	1	<b>Bottom Mount, HVDP Motors</b> M73, M74, M75, M76 HVDP - M77	110035-1 110035-3
23	1	<b>Cord</b> M3T, M73, M3TV, M75, M7TV M5T, M74, M5TV, M76, M8TV	110113 106666
24	1	<b>Cord Grip</b> All Models	110033
N/S	1	<b>Logo Label</b> All Models	110009
N/S	1	<b>Filter</b> M5T, M74, M5TV, M76, M8TV	110065
N/S	1	<b>Heat Sink Screw</b> M3TV, M5TV, M75, M76, M7TV, M8TV	106817
N/S	1	<b>Brush Kit - 115V</b> M3T, M3TV, M73, M75, M7TV	111059
N/S	1	<b>Brush Kit - 230V</b> M5T, M5TV, M74, M76, M8TV	111060

\*Items should be ordered together  
N/S = Not shown

## EXPLOSION PROOF MOTOR PARTS

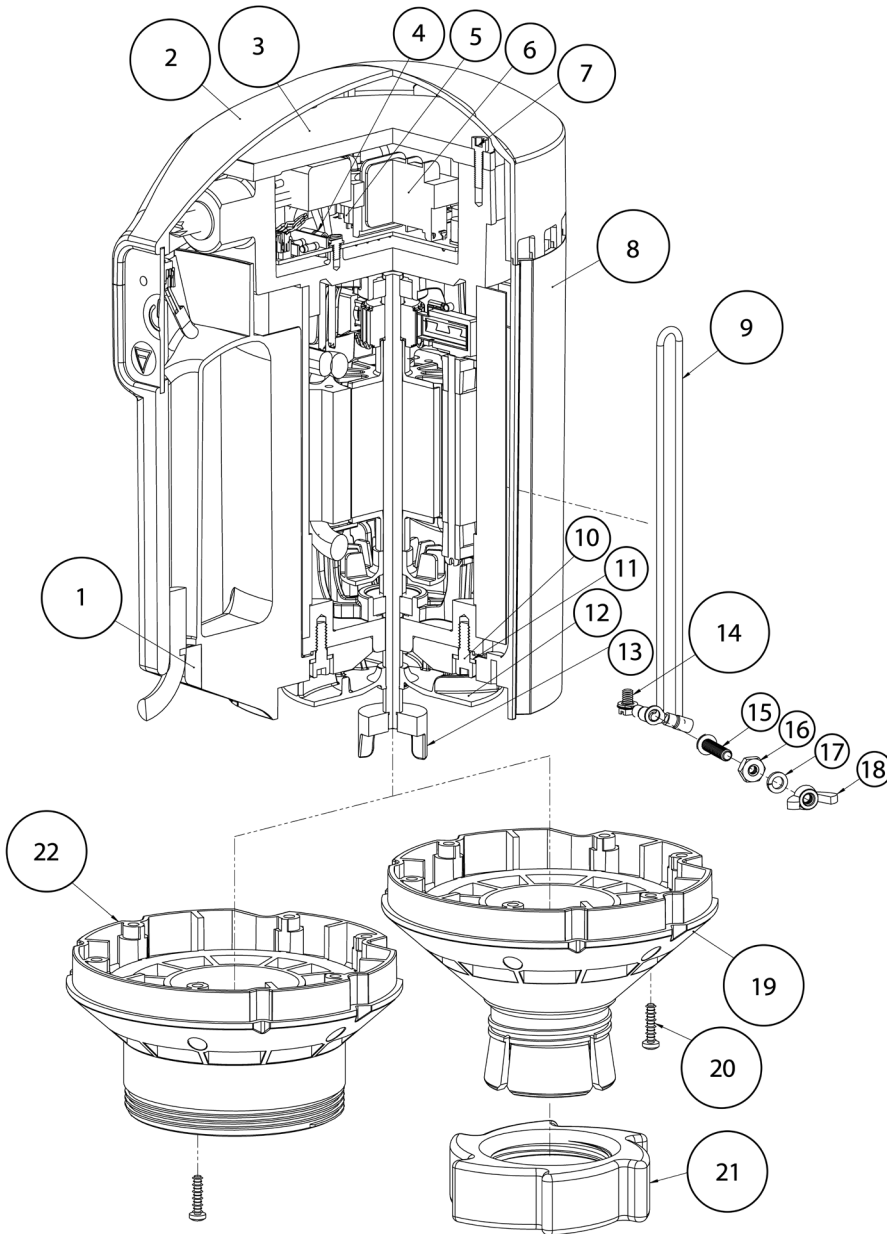

ITEM	QTY	DESCRIPTION	PART #
1	1	<b>Cord Grip</b>	
		M5XV, M5XV-HT, M78, M78-HT, M8XV	110033-2
		M3XV, M77, M7XV	110033-1
2	1	<b>Cover</b>	
		All Models	110031-2
3	1	<b>Enclosure Cover</b>	
		All Models	110036-1
4	2	<b>Terminal</b>	
		M5XV, M5XV-HT, M78, M78-HT, M8XV	J102619
		M3XV, M77, M7XV	J102619
5	4	<b>Female Quick Disconnect</b>	
		All Models	110047
6	1	<b>Printed Circuit Board</b>	
		All Models	110038
7	5	<b>Cap Screw Socket Head</b>	
		All Models	J101536
8	1	<b>Canister</b>	
		M5XV, M5XV-HT, M78, M78-HT, M8XV	110032-2
		M3XV, M77, M7XV	110032-1
9	1	<b>Ground Wire Assy</b>	
		All Models	110030
10	4	<b>Cap Screw, Socket Head</b>	
		All Models	J102643
11	4	<b>Washer, Lock</b>	
		All Models	J100672
12	1	<b>Fan</b>	
		M5XV, M5XV-HT, M78, M78-HT, M8XV	110034-2
		M3XV, M77, M7XV	110034-1
13	1	<b>Coupling Half, Threaded</b>	
		All Models	J100012-2
14	2	<b>Ground Screw</b>	
		All Models	J101534
15	1	<b>Wing Nut Stud</b>	
		All Models	J101181
16	1	<b>Hex Nut</b>	
		All Models	J100990
17	1	<b>Lock Washer</b>	
		All Models	J100824
18	1	<b>Wing Nut</b>	
		All Models	J103024
19*	1	<b>Bottom Mount</b>	
		M5XV, M5XV-HT, M8XV	110035-4
		M3XV, M7XV	110035-2
20	14	<b>Phillips Head Screw</b>	
		All Models	J101020
21*	1	<b>Collet Nut</b>	
		M5XV, M5XV-HT, M8XV, M3XV, M7XV	106541-1
22	1	<b>Bottom Mount</b>	
		HVDP - M78, M78-HT	110035-5
		HVDP - M77	110035-3
N/S	3	<b>Printed Circuit Board Screw</b>	
		All Models	106817
N/S	1	<b>Logo Label</b>	
		All Models	110009

\*Items should be ordered together  
N/S = Not shown



### FINISH THOMPSON INC.

921 Greengarden Road • Erie, PA 16501-1591 U.S.A.  
Ph 814-455-4478 • Fax 814-455-8518  
Email [fti@finishthompson.com](mailto:fti@finishthompson.com) • [www.finishthompson.com](http://www.finishthompson.com)

Tech Service 1-800-888-3743  
[techservice@finishthompson.com](mailto:techservice@finishthompson.com)  
Part no. 110062, Rev. 7, 6/22/2022